

Multimode (LVD/SE) SCSI 9 Line Terminator

FEATURES

- Auto Selection Multi-Mode Single Ended or Low Voltage Differential Termination
- 2.7V to 5.25V Operation
- Differential Failsafe Bias
- Built-in SPI-3 Mode Change Filter/Delay
- Meets SCSI-1, SCSI-2, Ultra2 (SPI-2 LVD) and Ultra3/Ultra160 Standards
- Supports Active Negation
- 3pF Channel Capacitance
- Reversed Disconnect Polarity

DESCRIPTION

The UCC5673 Multi-Mode Low Voltage Differential and Single Ended Terminator is both a single ended terminator and a low voltage differential terminator for the transition to the next generation SCSI Parallel Interface (SPI-3). The low voltage differential is a requirement for the higher speeds at a reasonable cost and is the only way to have adequate skew budgets.

The automatic mode select/change feature switches the terminator between Single Ended or LVD Termination, depending on the bus mode. If the bus is in High Voltage Differential Mode, the terminator lines transition into a High Impedance state.

The UCC5673 is SPI-3, SPI-2, and SCSI-2 compliant. This device is offered in a 28 pin TSSOP package to minimize the footprint. The UCC5673 is also available in a 36 pin MWP package.

BLOCK DIAGRAM

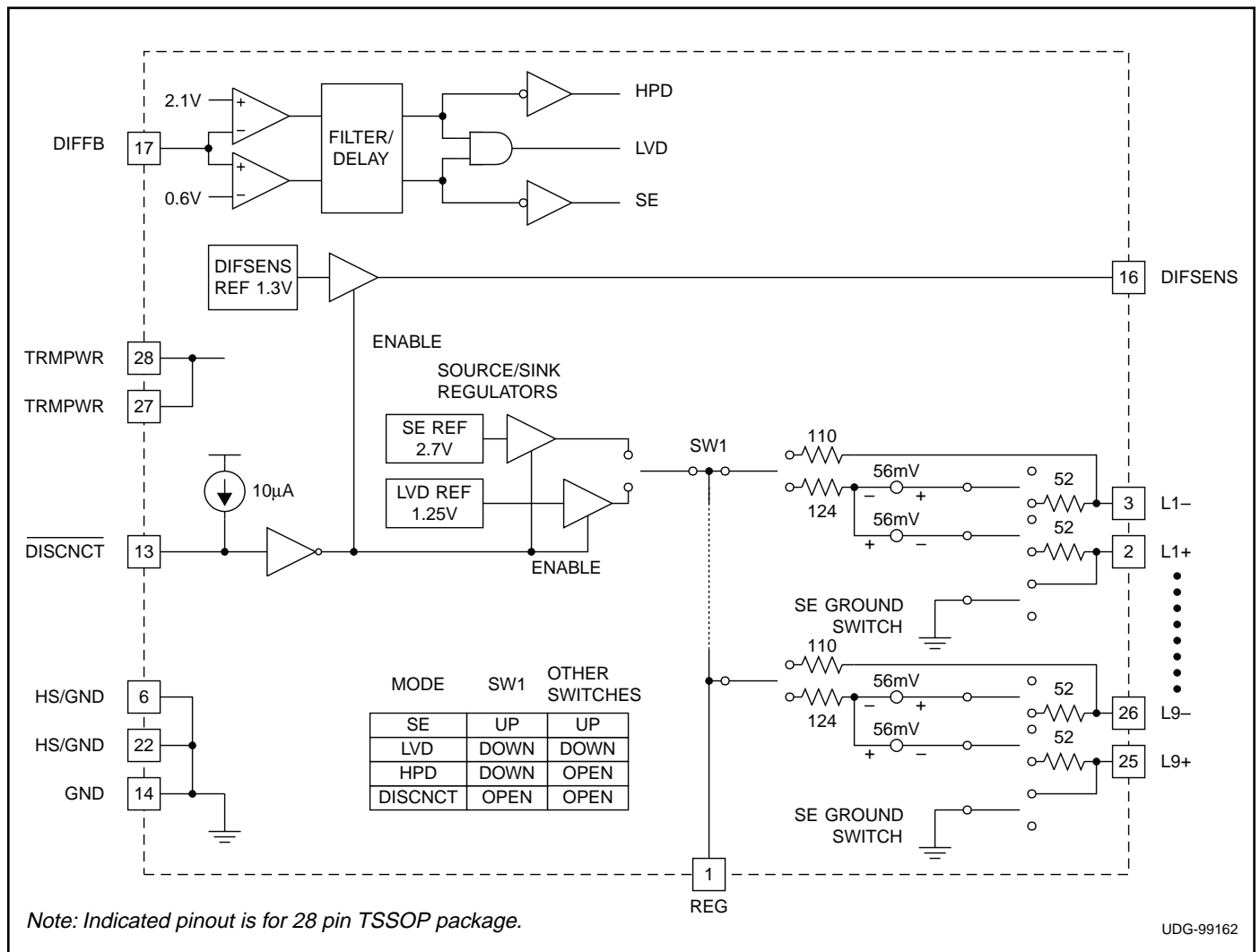

ABSOLUTE MAXIMUM RATINGS

TRMPWR Voltage	6V
Signal Line Voltage	0V to 5V
Storage Temperature	-65°C to +150°C
Junction Temperature	-55°C to +150°C
Lead Temperature (Soldering, 10sec.)	+300°C

All voltages are with respect to GND. Currents are positive into, negative out of the specified terminal. Consult Packaging Section of the Databook for thermal limitations and considerations of packages.

RECOMMENDED OPERATING CONDITIONS

TRMPWR Voltage	2.7V to 5.25V
----------------	---------------

CONNECTION DIAGRAM

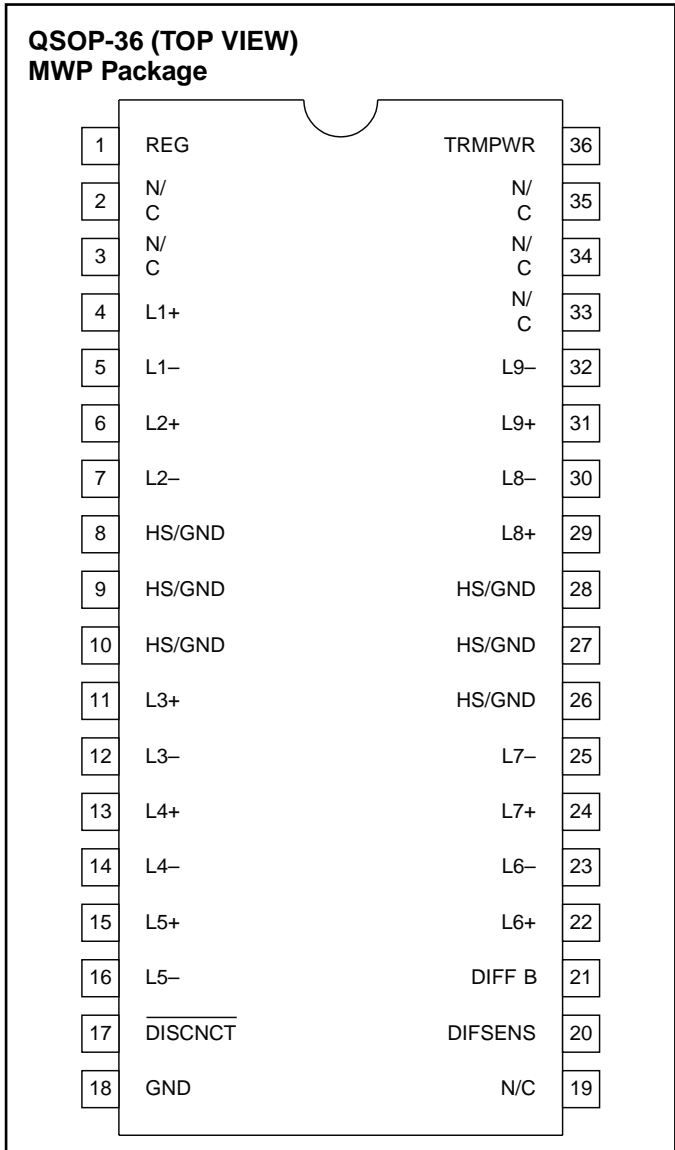
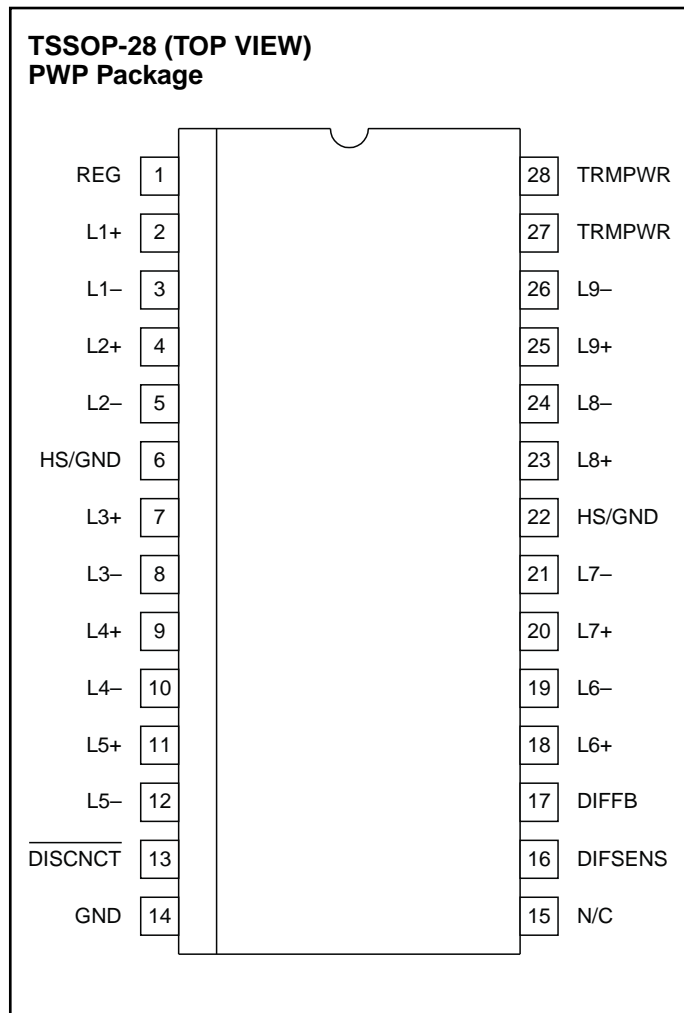

ELECTRICAL CHARACTERISTICS Unless otherwise stated, these specifications apply for $T_A = T_J = 0^\circ\text{C}$ to 70°C , TRMPWR = 2.7V to 5.25V.

PARAMETER	TEST CONDITIONS	MIN	TYP	MAX	UNITS
TRMPWR Supply Current Section					
TRMPWR Supply Current	LVD Mode		23	35	mA
	SE Mode		14	25	mA
	DISCNCT Mode		250	500	μA
Regulator Section					
1.25V Regulator Output Voltage	LVD Mode	1.15	1.25	1.35	V
1.25V Regulator Source Current	$V_{\text{REG}} = 0\text{V}$	-800	-420	-225	mA
1.25V Regulator Sink Current	$V_{\text{REG}} = 3.3\text{V}$	100	180	420	mA
2.7V Regulator Output Voltage	SE Mode	2.5	2.7	3.0	V
2.7V Regulator Source Current	$V_{\text{REG}} = 0\text{V}$	-800	-420	-225	mA
2.7V Regulator Sink Current	$V_{\text{REG}} = 3.3\text{V}$	100	180	420	mA
Diff Sense Driver (DIFSENS) Section					
1.3V DIFSENS Output Voltage	DIFSENS	1.2	1.3	1.4	V
1.3V DIFSENS Source Current	$V_{\text{DIFSENS}} = 0\text{V}$	-15		-5	mA
1.3V DIFSENS Sink Current	$V_{\text{DIFSENS}} = 2.75\text{V}$	50		200	μA
Differential Termination Section					
Differential Impedance		100	105	110	Ω
Common Mode Impedance	(Note 2)	110	150	165	Ω
Differential Bias Voltage		100		125	mV
Common Mode Bias		1.15	1.25	1.35	V
Output Capacitance	Single Ended Measurement to Ground (Note 1)			3	pF
Single Ended Termination Section					
Impedance	$Z = (V_{LX} - 0.2\text{V}) / I_{LX}$, (Note 3)	100	108	116	Ω
Termination Current	Signal Level 0.2V, All Lines Low	-25.4	-23	-20	mA
	Signal Level 0.5V	-22.4		-17	mA
Output Leakage				400	nA
Output Capacitance	Single Ended Measurement to Ground (Note 1)			3	pF
Single Ended GND SE Impedance	$I = 10\text{mA}$		20	60	Ω
Disconnect (DISCNCT) and Diff Buffer (DIFFB) Input Section					
DISCNCT Threshold		0.8		2.0	V
DISCNCT Input Current		-30	-10		μA
DIFFB SE to LVD Threshold		0.5		0.7	V
DIFFB LVD to HPD Threshold		1.9		2.4	V
DIFFB Input Current		-1		1	μA

ELECTRICAL CHARACTERISTICS Unless otherwise stated, these specifications apply for $T_A = T_J = 0^\circ\text{C}$ to 70°C , $\text{TRMPWR} = 2.7\text{V}$ to 5.25V .

PARAMETER	TEST CONDITIONS	MIN	TYP	MAX	UNITS
Time Delay/Filter Section					
Mode Change Delay	A new mode change can start any time after a previous mode change has been detected. (Note 4)	100	180	300	ms

Note 1: Guaranteed by design. Not 100% tested in production.

$$\text{Note 2: } Z_{CM} = \frac{1.2\text{V}}{I_{(V_{CM}+0.6\text{V})} - I_{(V_{CM}-0.6\text{V})}};$$

Where V_{CM} = Voltage measured with L+ tied to L- and zero current applied;

Note 3: V_{LX} = Output voltage for each terminator minus output pin (L1- through L9-) with each pin unloaded.
 I_{LX} = Output current for each terminator minus output pin (L1- through L9-) with the minus output pin forced to 0.2V.

Note 4: Noise on DIFFB will not cause a false mode change. The time delay is that same for a change from any mode to any other mode. Within 300ms after power is applied the mode is defined by the voltage of DIFFB.

PIN DESCRIPTIONS

DIFFB: Input pin for the comparators that select SE, LVD, or HIPD modes of operation. This pin should be decoupled with a $0.1\mu\text{F}$ capacitor to ground and then coupled to the DIFSENS pin through a $20\text{k}\Omega$ resistor.

DIFSENS: Connects to the Diff Sense line of the SCSI bus. The bus mode is controlled by the voltage level on this pin.

DISCNCT: Input pin used to shut down the terminator if the terminator is not connected at the end of the bus. Connect this pin to ground to disable the terminator or open pin to activate the terminator.

HS/GND: Heat sink ground pins. These should be connected to large ground area PC board traces to increase the power dissipation capability.

GND: Power Supply return.

L1- thru L9-: Termination lines. These are the active lines in SE mode and are the negative lines for LVD mode. In HIPD mode, these lines are high impedance.

L1+ thru L9+: Termination lines. These lines switch to ground in SE mode and are the positive lines for LVD mode. In HIPD mode, these lines are high impedance.

TRMPWR: 2.7V to 5.25V power input pin.

APPLICATION INFORMATION

All SCSI buses require a termination network at each end to function properly. Specific termination requirements differ, depending on which types of SCSI devices are present on the bus.

The UCC5673 is used in multi-mode active termination applications, where single ended (SE) and low voltage differential (LVD) devices might coexist. The UCC5673 has both SE and LVD termination networks integrated into a single monolithic component. The correct termination network is automatically determined by the SCSI bus "DIFSENS" signal.

The SCSI bus DIFSENS signal line is used to identify which types of SCSI devices are present on the bus. On power-up, the UCC5673 DIFSENS drivers will try to de-

liver 1.3V to the DIFSENS line. If only LVD devices are present, the DIFSENS line will be successfully driven to 1.3V and the terminators will configure for LVD operation. If any single ended devices are present, they will present a short to ground on the DIFSENS line, signaling the UCC5673(s) to configure into the SE mode, accommodating the SE devices. Or, if any high voltage differential (HVD) devices are present, the DIFSENS line is pulled high and the terminator will enter a high impedance state, effectively disconnecting from the bus.

The DIFSENS line is monitored by each terminator through a 50Hz noise filter at the DIFFB input pin. A set of comparators detect and select the appropriate termination for the bus as follows. If the DIFSENS signal is be-

APPLICATION INFORMATION (cont.)

low 0.5V, the termination network is SE. Between 0.7V and 1.9V, the termination network switches to LVD, and above 2.4V is HVD, causing the terminators to disconnect from the bus. The thresholds accommodate differences in ground potential that can occur with long lines.

Three UCC5673 multi-mode parts are required at each end of the bus to terminate 27 (18 data, plus 9 control)

lines. Each part includes a DIFSENS driver, but only one is necessary to drive the line. The DIFFB inputs on all three parts are connected together, allowing them to share the same 50Hz noise filter. This multi-mode terminator operates in full specification down to 2.7V TRMPWR voltage. This accommodates 3.3V systems, with allowance for the 3.3V supply tolerance (+/- 10%), a unidirectional fusing device and cable drop. In 3.3V

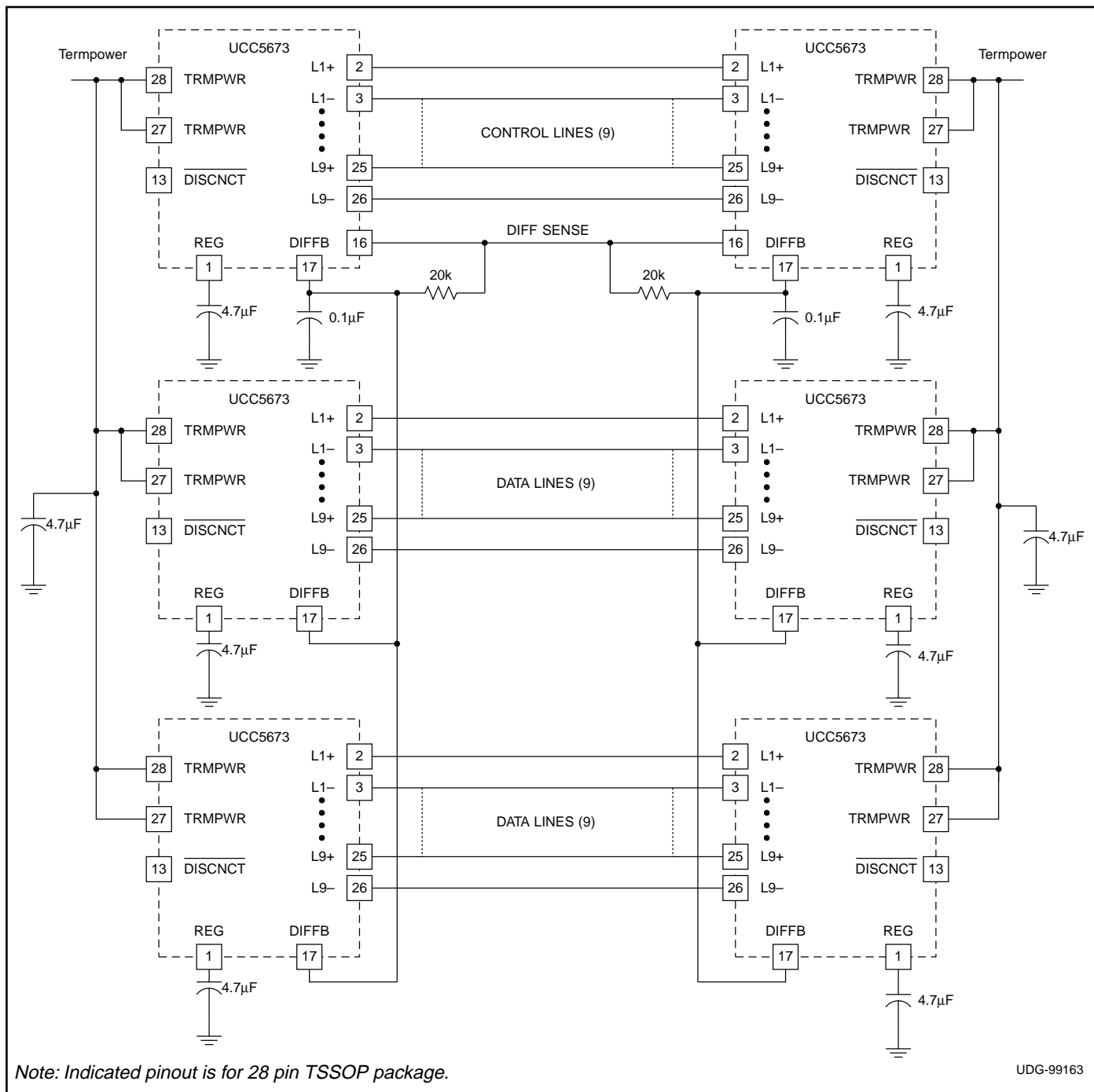

Note: Indicated pinout is for 28 pin TSSOP package.

UDG-99163

Figure 1. Application diagram.

APPLICATION INFORMATION (cont.)

TRMPWR systems, the UCC3918 is recommended in place of the fuse and diode. The UCC3918's lower voltage drop allows additional margin over the fuse and diode, for the far end terminator.

Layout is critical for Ultra2 and Ultra3 systems. The SPI-2 standard for capacitance loading is 10pF maximum from each positive and negative signal line to ground, and a maximum of 5pF between the positive and negative signal lines of each pair is allowed. These maximum capacitances apply to differential bus termination circuitry that is not part of a SCSI device, (e.g. a cable terminator). If the termination circuitry is included as part of a SCSI device, (e.g., a host adaptor, disk or tape drive), then the corresponding requirements are 30pF maximum from each positive and negative signal line to ground and 15pF maximum between the positive and negative signal lines of each pair.

The SPI-2 standard for capacitance balance of each pair and balance between pairs is more stringent. The standard is 0.75pF maximum difference from the positive and negative signal lines of each pair to ground. An additional requirement is a maximum difference of 2pF when comparing pair to pair. These requirements apply to differential bus termination circuitry that is not part of a SCSI device. If the termination circuitry is included as part of a device, then the corresponding balance requirements are 2.25pF maximum difference within a pair, and 3pF from pair to pair.

Feed-throughs, through-hole connections, and etch lengths need to be carefully balanced. Standard multi-layer power and ground plane spacing add about 1pF to each plane. Each feed-through will add about

2.5pF to 3.5pF. Enlarging the clearance holes on both power and ground planes will reduce the capacitance. Similarly, opening up the power and ground planes under the connector will reduce the capacitance for through-hole connector applications. Capacitance will also be affected by components, in close proximity, above and below the circuit board.

Unitrode multi-mode terminators are designed with very tight balance, typically 0.1pF between pins in a pair and 0.3pF between pairs. At each L+ pin, a ground driver drives the pin to ground, while in single ended mode. The ground driver is specially designed to not effect the capacitive balance of the bus when the device is in LVD or disconnect mode.

Multi-layer boards need to adhere to the 120Ω impedance standard, including the connectors and feed-throughs. This is normally done on the outer layers with 4 mil etch and 4 mil spacing between runs within a pair, and a minimum of 8 mil spacing to the adjacent pairs to reduce crosstalk. Microstrip technology is normally too low of impedance and should not be used. It is designed for 50Ω rather than 120Ω differential systems. Careful consideration must be given to the issue of heat management. A multi-mode terminator, operating in SE mode, will dissipate as much as 130mW of instantaneous power per active line with TRMPWR = 5.25V. The UCC5673 is offered in a 28 pin TSSOP. This package includes two heat sink ground pins. These heat sink/ground pins are directly connected to the die mount paddle under the die and conduct heat from the die to reduce the junction temperature. Both of the HS/GND pins need to be connected to etch area or four feed-through per pin connecting to the ground plane layer on a multi-layer board.

IMPORTANT NOTICE

Texas Instruments Incorporated and its subsidiaries (TI) reserve the right to make corrections, modifications, enhancements, improvements, and other changes to its products and services at any time and to discontinue any product or service without notice. Customers should obtain the latest relevant information before placing orders and should verify that such information is current and complete. All products are sold subject to TI's terms and conditions of sale supplied at the time of order acknowledgment.

TI warrants performance of its hardware products to the specifications applicable at the time of sale in accordance with TI's standard warranty. Testing and other quality control techniques are used to the extent TI deems necessary to support this warranty. Except where mandated by government requirements, testing of all parameters of each product is not necessarily performed.

TI assumes no liability for applications assistance or customer product design. Customers are responsible for their products and applications using TI components. To minimize the risks associated with customer products and applications, customers should provide adequate design and operating safeguards.

TI does not warrant or represent that any license, either express or implied, is granted under any TI patent right, copyright, mask work right, or other TI intellectual property right relating to any combination, machine, or process in which TI products or services are used. Information published by TI regarding third-party products or services does not constitute a license from TI to use such products or services or a warranty or endorsement thereof. Use of such information may require a license from a third party under the patents or other intellectual property of the third party, or a license from TI under the patents or other intellectual property of TI.

Reproduction of TI information in TI data books or data sheets is permissible only if reproduction is without alteration and is accompanied by all associated warranties, conditions, limitations, and notices. Reproduction of this information with alteration is an unfair and deceptive business practice. TI is not responsible or liable for such altered documentation. Information of third parties may be subject to additional restrictions.

Resale of TI products or services with statements different from or beyond the parameters stated by TI for that product or service voids all express and any implied warranties for the associated TI product or service and is an unfair and deceptive business practice. TI is not responsible or liable for any such statements.

TI products are not authorized for use in safety-critical applications (such as life support) where a failure of the TI product would reasonably be expected to cause severe personal injury or death, unless officers of the parties have executed an agreement specifically governing such use. Buyers represent that they have all necessary expertise in the safety and regulatory ramifications of their applications, and acknowledge and agree that they are solely responsible for all legal, regulatory and safety-related requirements concerning their products and any use of TI products in such safety-critical applications, notwithstanding any applications-related information or support that may be provided by TI. Further, Buyers must fully indemnify TI and its representatives against any damages arising out of the use of TI products in such safety-critical applications.

TI products are neither designed nor intended for use in military/aerospace applications or environments unless the TI products are specifically designated by TI as military-grade or "enhanced plastic." Only products designated by TI as military-grade meet military specifications. Buyers acknowledge and agree that any such use of TI products which TI has not designated as military-grade is solely at the Buyer's risk, and that they are solely responsible for compliance with all legal and regulatory requirements in connection with such use.

TI products are neither designed nor intended for use in automotive applications or environments unless the specific TI products are designated by TI as compliant with ISO/TS 16949 requirements. Buyers acknowledge and agree that, if they use any non-designated products in automotive applications, TI will not be responsible for any failure to meet such requirements.

Following are URLs where you can obtain information on other Texas Instruments products and application solutions:

Products		Applications	
Amplifiers	amplifier.ti.com	Audio	www.ti.com/audio
Data Converters	dataconverter.ti.com	Automotive	www.ti.com/automotive
DLP® Products	www.dlp.com	Communications and Telecom	www.ti.com/communications
DSP	dsp.ti.com	Computers and Peripherals	www.ti.com/computers
Clocks and Timers	www.ti.com/clocks	Consumer Electronics	www.ti.com/consumer-apps
Interface	interface.ti.com	Energy	www.ti.com/energy
Logic	logic.ti.com	Industrial	www.ti.com/industrial
Power Mgmt	power.ti.com	Medical	www.ti.com/medical
Microcontrollers	microcontroller.ti.com	Security	www.ti.com/security
RFID	www.ti-rfid.com	Space, Avionics & Defense	www.ti.com/space-avionics-defense
RF/IF and ZigBee® Solutions	www.ti.com/lprf	Video and Imaging	www.ti.com/video
		Wireless	www.ti.com/wireless-apps