

PTHF4900DK



Description

The PTHF4900DK can be used for a variety of applications from chemical metering, to temperature regulating, to energy management. The infinite adjustability from 1 to 99% provides accurate percentage on control over a wide factory fixed cycle period. When mounted on a metal surface, it can be used to drive solenoids, contactors, relays, or lamps, up to 20A steady, 200A inrush. The PTHF4900DK is the suggested replacement for the PT Series.

Operation (Percentage)

Upon application of input voltage, the output energizes and the T1 ON time begins. At the end of the ON time, the output de-energizes and the T2 OFF time begins. At the end of the OFF time, the output energizes and the cycle repeats as long as input voltage is applied. Increasing the ON time decreases the OFF time. The total cycle period is equal to the ON time plus the OFF time. The total cycle period is factory fixed. ON time range is 1 to 99 percent of cycle period.

Reset: Removing input voltage resets the output and time delays, and returns the sequence to the T1 ON time.

Wiring Diagram

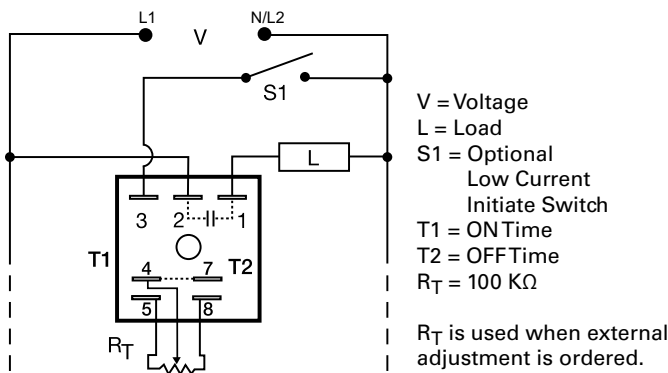

Features & Benefits

FEATURES	BENEFITS
Microcontroller based	Repeat accuracy + / - 0.5%, Factory calibration + / - 5%
ON/OFF recycling percentage control 1 to 99%	Accurate control over a wide factory fixed cycle period
Compact, low cost design	Allows flexibility for OEM applications and reduces component and labor costs
High load currents up to 20A, 200A inrush	Allows direct operation of motors, lamps, and heaters without a contactor
Totally solid state and encapsulated	No moving parts to arc and wear out over time and encapsulated to protect against shock, vibration, and humidity
Metalized mounting surface	Facilitates heat transfer in high current applications

Accessories



P1004-95, P1004-95-X Versa-Pot

Panel mountable, industrial potentiometer recommended for remote time delay adjustment.



P0700-7 Versa-Knob

Designed for 0.25 in. (6.35 mm) shaft of Versa-Pot. Semi-gloss industrial black finish.



P1015-13 (AWG 10/12), P1015-64 (AWG 14/16) Female Quick Connect

These 0.25 in. (6.35 mm) female terminals are constructed with an insulator barrel to provide strain relief.



P1015-18 Quick Connect to Screw Adapter

Screw adapter terminal designed for use with all modules with 0.25 in. (6.35 mm) male quick connect terminals.

PTHF4900DK

Specifications

Time Delay

Type	External or onboard knob
Range/External Adjustment Resistance	Adjustable from 1 - 99% / $R_T = 100\text{ K}\Omega$
Cycle Period	Fixed from 10s - 1000m
Repeat Accuracy	$\pm 0.5\%$ or 20ms, whichever is greater
Cycle Period Tolerance (Factory Calibration)	$\leq \pm 5\%$
Reset Time	$\leq 150\text{ms}$
Time Delay vs Temp. & Voltage	$\leq \pm 10\%$

Input

Voltage	120 or 230VAC
Tolerance	$\pm 20\%$
AC Line Frequency	50/60 Hz
Power Consumption	$\leq 2\text{VA}$

Output

Type	Solid state	
Maximum Load Currents	Steady State	Inrush*
	1A	10A

Voltage Drop	$\approx 2.5\text{V}$ at rated current
OFF State Leakage Current	$\approx 5\text{mA}$ @ 230VAC

Protection

Circuitry	Encapsulated
Dielectric Breakdown	$\geq 2000\text{V RMS}$ terminals to mounting surface
Insulation Resistance	$\geq 100\text{ M}\Omega$

Mechanical

Mounting * Dimensions

Surface mount with one #10 (M5 x 0.8) screw
H 50.8 mm (2"); **W** 50.8 mm (2");
D 38.4 mm (1.51")
 0.25 in. (6.35 mm) male quick connect terminals

Termination

Environmental

Operating/Storage

Temperature

Humidity

-40° to 60°C / -40° to 85°C
 95% relative, non-condensing
 6, 10, 20A units: $\approx 3.9\text{ oz}$ (111 g)

*Units rated $\geq 6\text{A}$ must be bolted to a metal surface using the included heat sink compound. The maximum mounting surface temperature is 90°C. Inrush: Non-repetitive for 16ms.

Function Diagram

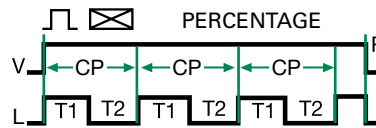

V = Input Voltage
 CP = Cycle Period
 L = Load
 T1 = ONTime
 T2 = OFFTime
 R = Reset