

REVISIONS			
REV	DESCRIPTION, ECG, EAR NO.	DATE	APPD
E	PRODUCT DRAWING EAR 14606	SEP12/17	K.L.
F	PRODUCT DRAWING EAR 14608	SEP20/17	K.L.

ORDERING CODE: M USBR - M5C1 - XX

SERIES, RUGGED USB

USB TYPE 'C' RECEPTACLE, SINGLE PORT, VERTICAL PCB TAILS, 24 CONTACTS

MOUNTING HOLE THREAD OPTION:
 3 = #2-56 UNC THREAD
 M = M2.5 X 0.45 THREAD

DUST COVER OPTION
 0 = NO DUST COVER SUPPLIED
 1 = WITH GREY DUST COVER SUPPLIED
 5 = WITH BLACK DUST COVER SUPPLIED
 SEE SHEET 2 FOR DUST COVER VIEWS

NOTES:

- MATERIAL:**
 ALL MATERIALS ARE RoHS COMPLIANT PER EU DIRECTIVE 2011/65/EU AND AMENDMENTS
 - OUTER SHELL: DIECAST ZINC ALLOY, MATTE TIN OVER NICKEL PLATING
 - CONTACTS: COPPER ALLOY, PLATED WITH 0.76µm [30µ"] MINIMUM GOLD OVER 1.27µm [50µ"] MINIMUM NICKEL ON THE MATING AREA WITH MATTE TIN OVER NICKEL ON THE TAILS
 - USB HOUSING: ENGINEERING THERMOPLASTIC, HIGH TEMPERATURE RESISTANT, FLAMMABILITY RATING UL94V-0, BLACK
 - USB SHIELD: STAINLESS STEEL, PASSIVATED
 - REAR COVER: STAINLESS STEEL, MATTE TIN OVER NICKEL PLATING
 - GASKET: CONDUCTIVE SILICONE RUBBER, BLACK
 - DUST COVER - SILICONE RUBBER WITH NICKEL PLATED BRASS BUSHING. SEE ORDERING CODE FOR COLOUR OPTION.
- ENVIRONMENTAL PERFORMANCE PER IEC 60529 CODE IP67 FOR SEAL BETWEEN MATING AREA AND PCB SIDE OF CONNECTOR. GASKET PROVIDES SEAL TO INSIDE FACE OF ENCLOSURE PANEL.**
- CURRENT RATING: COLLECTIVELY 5A MAX. FOR PINS A4, A9, B4 & B9 PLUS 1.25A MAX. FOR PIN B5 WITH RETURN PATH SHARED THROUGH PINS A1, A12, B1 & B12. ADDITIONAL POSITIONS 0.25A MAX. EACH.**
- CONTACT RESISTANCE: 40 MILLIOHMS MAXIMUM INITIAL.**
- OPERATING TEMPERATURE: -40°C TO +105°C.**
- DUST COVERS MAY BE ORDERED SEPARATELY. SPECIFY**
 - PART NUMBER MUSBR-2M5C-004BP FOR GREY COVER OR
 - PART NUMBER MUSBR-2M5C-014BP FOR BLACK COVER

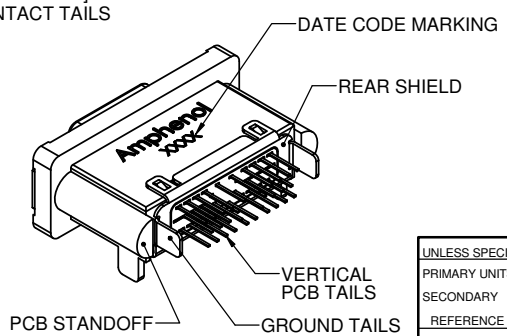
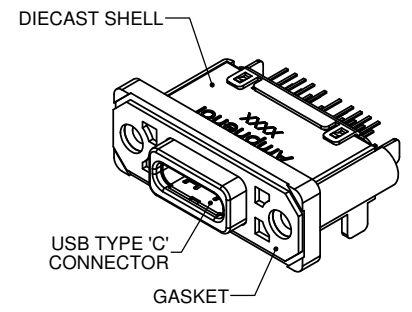
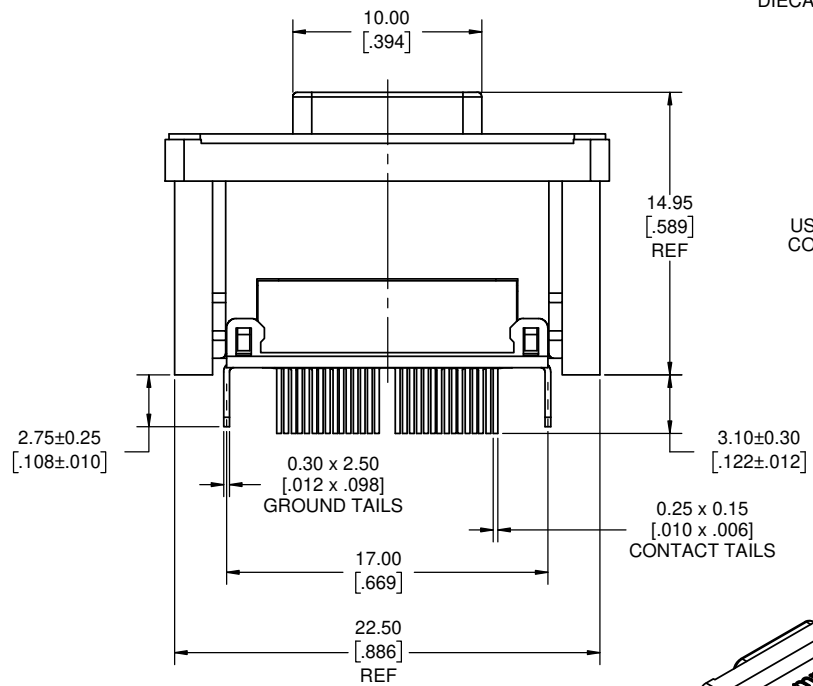

THIS DOCUMENT CONTAINS PROPRIETARY INFORMATION AND SUCH INFORMATION MAY NOT BE DISCLOSED TO OTHERS FOR ANY PURPOSE OR USED FOR MANUFACTURING PURPOSES WITHOUT WRITTEN PERMISSION FROM AMPHENOL CANADA CORP.

UNLESS SPECIFIED OTHERWISE	DRAWN	J. FISHER	MAR25/15
PRIMARY UNITS MILLIMETERS	CHECKED	K. LAMBIE	MAR26/15
SECONDARY INCHES	M.E. APPD		
REFERENCE IN PARENTHESES	Q.A. APPD		
GENERAL TOLERANCES	DWG APPR.		
1 DECIMAL PLACE	ENG. REL. NO.	EAR 14354	
2 DECIMAL PLACES ±0.15	REF.		
3 DECIMAL PLACES ±0.05	THIRD ANGLE PROJECTION		
ANGULAR DEGREES	DO NOT SCALE DRAWING		

Amphenol Canada Corp.
www.amphenolcanada.com

RUGGED USB TYPE 'C' RECEPTACLE, VERTICAL PCB MOUNT, RoHS COMPLIANT

DWG. NO. **P-MUSBR-M5C1-XX** REV **F**

CODE ID NO. 03554 DWG SIZE: X SCALE: 5:1 SHEET 1 OF 2

REVISIONS			
REV	DESCRIPTION, ECG, EAR NO.	DATE	APP'D
E	PRODUCT DRAWING EAR 14606	SEP12/17	K.L.
F	PRODUCT DRAWING EAR 14608	SEP20/17	K.L.

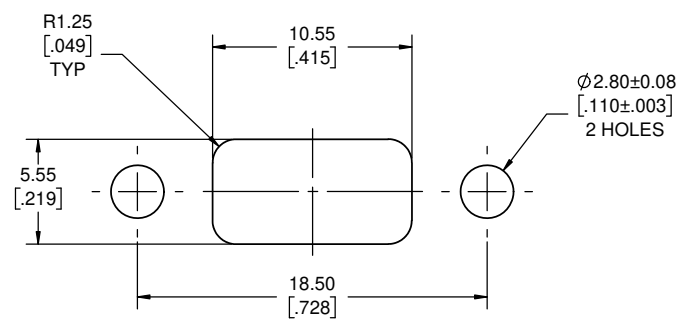

RECOMMENDED PANEL CUTOUT
OUTSIDE VIEW OF PANEL

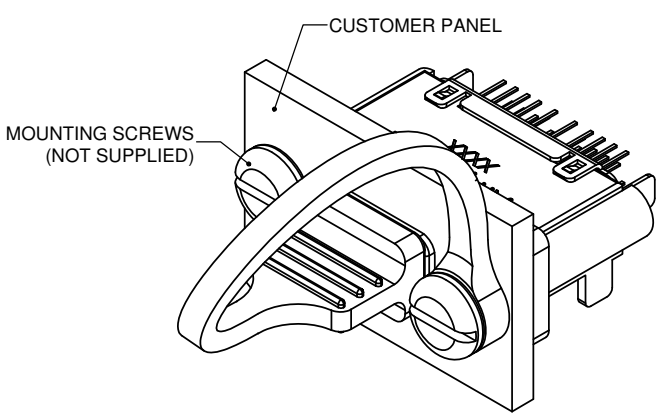

DUST COVER APPLICATION VIEW

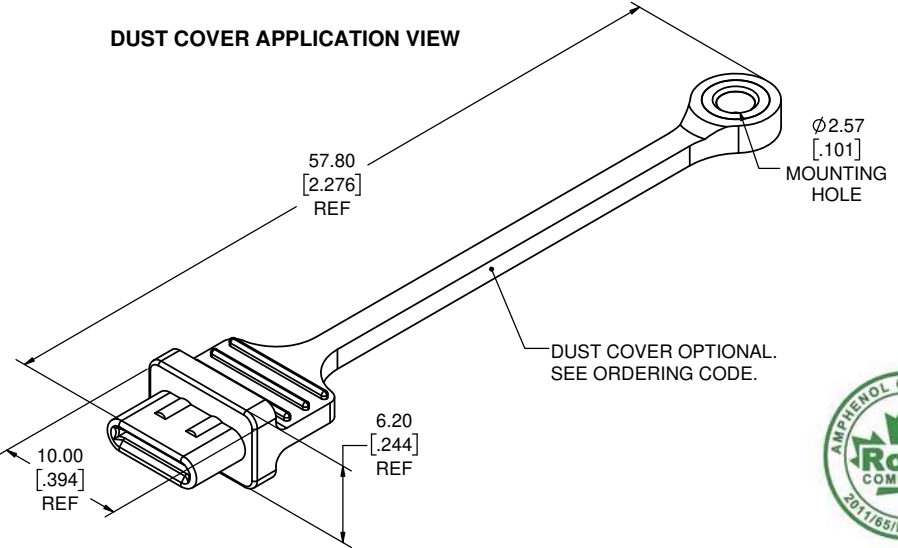

DUST COVER OPTIONAL.
SEE ORDERING CODE.

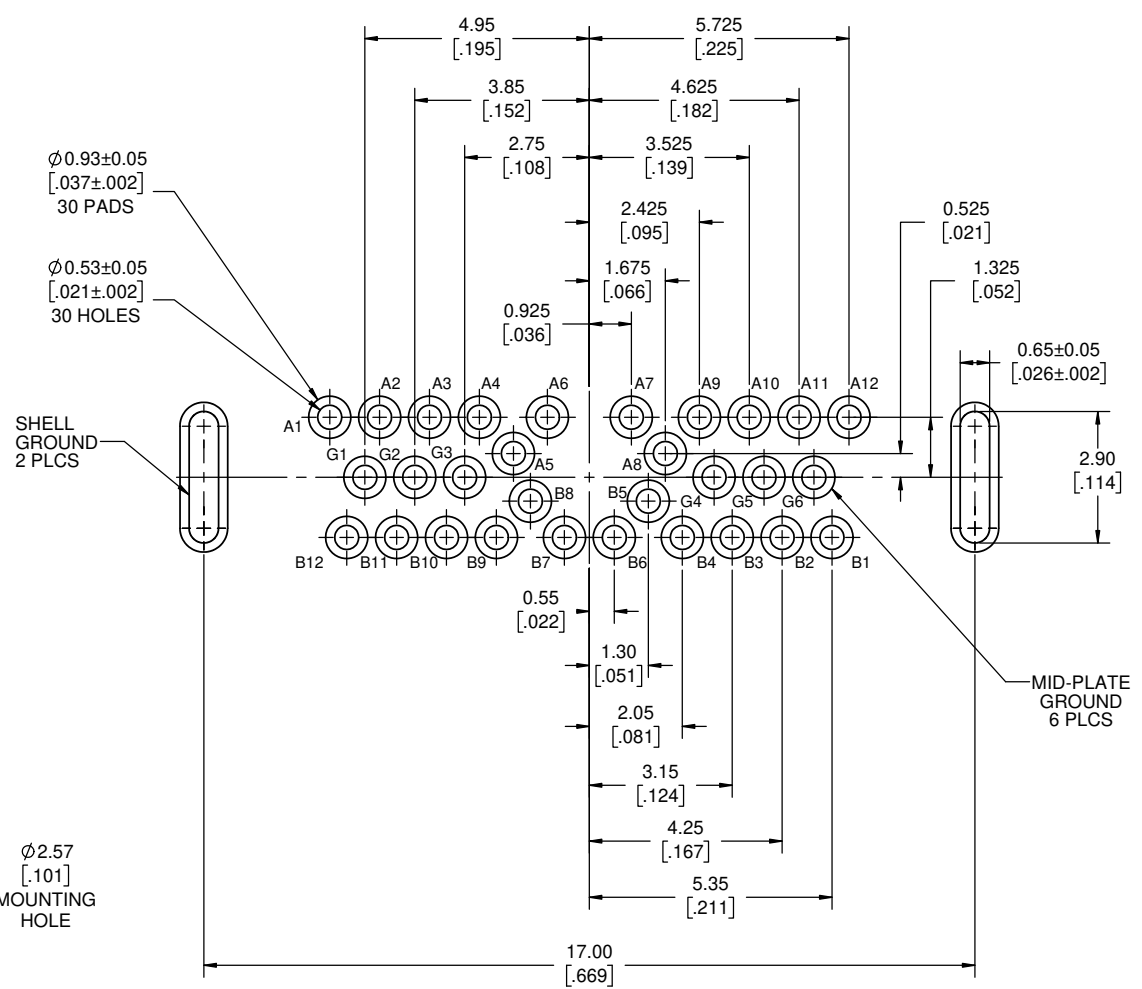

RECOMMENDED PCB LAYOUT
COMPONENT SIDE OF BOARD



UNLESS SPECIFIED OTHERWISE	DRAWN	J. FISHER	MAR25/15
PRIMARY UNITS MILLIMETERS	CHECKED	K. LAMBIE	MAR26/15
SECONDARY INCHES	M.E. APP'D		
REFERENCE IN PARENTHESES	Q.A. APP'D		
GENERAL TOLERANCES	DWG APPR.		
1 DECIMAL PLACE	ENG. REL. NO.	EAR 14354	
2 DECIMAL PLACES ± 0.15	REF.		
3 DECIMAL PLACES ± 0.05	THIRD ANGLE PROJECTION		
ANGULAR DEGREES	DO NOT SCALE DRAWING		

Amphenol Canada Corp.
www.amphenolcanada.com

**RUGGED USB TYPE 'C' RECEPTACLE,
VERTICAL PCB MOUNT,
RoHS COMPLIANT**

DWG. NO. **P-MUSBR-M5C1-XX** REV **F**

CODE ID NO. 03554 DWG SIZE: X SCALE: 5:1 SHEET 2 OF 2