

HG1120 INERTIAL MEASUREMENT UNIT (IMU)

Installation and Interface Manual



Table of Contents

4	Honeywell Industrial Inertial Measurement Units
5	Electrical Interface
6	Mode and Communication Selection Asynchronous Protocol SPI Protocol CAN 2A/2B Protocol
15	Mechanical Drawing and Installation
17	Export Guidance
17	Contact Us

Table of Tables

5	Table 1. Connector Pin Description
7	Table 2. Mode Selection
8	Table 3. Control Message (0x04 Data Format)
8	Table 4. Main Status Word Definition
9	Table 5. Multiplexed Status Word
9	Table 6. Gyro and Accelerometer BIT Status
9	Table 7. Processor/Memory BIT Status Word
10	Table 8. Inertial Message (0x05 Data Format)
10	Table 9. Asynchronous Control Message (0x0C Data Format)
11	Table 10. Asynchronous Inertial Message (0x0D Data Format)
12	Table 11. SPI Control Message (0x04 Data Format)
12	Table 12. SPI Inertial Message (0x05 Data Format)
12	Table 13. SPI Control Message (0x0C Data Format)

Table of Tables

- 12 [Table 14. SPI Inertial Message \(0x0D Data Format\)](#)
- 13 [Table 15. CAN Control Message 1 Format](#)
- 13 [Table 16. CAN Control Message 2 Format](#)
- 13 [Table 17. CAN Control Message 3 Format](#)
- 14 [Table 18. CAN Inertial Message 1 Format](#)
- 14 [Table 19. CAN Inertial Message 2 Format](#)
- 14 [Table 20. CAN Inertial Message 3 Format](#)

Honeywell Industrial Inertial Measurement Units



Honeywell produces No License Required (NLR) Inertial Measurement Units (IMU) for industrial applications including agricultural vehicles, robotics, survey, mapping, and stabilized systems. These IMUs are designed for industrial application and can be used on air, land, and sea. Honeywell began producing gyros in the 1940's for the Honeywell C-1 autopilot and specifically began producing MEMS gyros and accelerometers in the early 2000's. Honeywell's IMUs utilize proprietary Honeywell technology and leverage existing production and engineering infrastructure. Honeywell has deep and long lasting relations with many commercial customers and is carrying that philosophy and product pedigree into our NLR IMU line. Honeywell's forward looking product strategies ensure that our NLR IMUs fit your current and future needs.

The HG1120 IMU is a device which measures angular rates, linear accelerations, and magnetic fields in a body mounted strap down configuration. The IMU provides compensated incremental angle and velocity data for navigation as well as angular rates and linear accelerations for control. The data is reported through a digital serial interface bus and is available in a variety of serial formats. The unit contains MEMS gyroscopes and accelerometers as well as the electronics and software necessary to deliver precision control and navigation information. The input axes form a right handed frame aligned with the IMU mounting frame.

Electrical Interface

The pin assignments of the external system connector are shown below. **Logic 0 corresponds to the CMOS “low” logic state. Logic 1 corresponds to the CMOS “high” logic state.**

Table 1. Connector Pin Description

PIN #	SIGNAL NAME	INPUT/OUTPUT & SIGNAL TYPE	SIGNAL FUNCTION
1	DIO3	Input - Device Configuration CMOS compatible logic	No connect results in Logic 1. Active low for logic 0.
2	DIO4	Input – Device Configuration CMOS Compatible Logic	No connect results in Logic 1. Active low for logic 0.
3	SPL_SCLK	Input CMOS Compatible Logic	SPI Clock
4	SPI_MOSI	Input CMOS Compatible Logic	SPI Master Out Slave In (MOSI) data.
5	SPI_MISO	Output CMOS Compatible Logic	SPI Master In Slave Out (MISO) data
6	SPI_SS	Input CMOS Compatible Logic	SPI Slave Select (chip select), Default high, Active low
7	DIO1	Input – Device Configuration CMOS Compatible Logic	No connect results in Logic 1. Active low for logic 0.
8	RESET_N	Input – Device Configuration CMOS Compatible Logic	Logic 0 applied for 15 milli-seconds will stop all processing. Upon logic 1, the IMU will restart as if power had been removed and re-applied. No connection is required.
9	DATA_RDY	Output CMOS Compatible Logic	Data Ready on Rising Edge to Logic 1. @ Logic 1, maximum 500 micro-seconds.
10	DIO2	Input - Device Configuration CMOS Compatible Logic	No connect results in Logic 1. Active low for logic 0.
11,12	VDD	Input Power (3.0 – 5.5 VDC)	The input voltage should monotonically increase at start with ripple < 30 mV P-P. The device draws < 0.4 Watts and 125 mA.
13	PWR_RTN	Power Return	Return path for input power.
14	DGND	Signal Return	Use this pin to reference digital signals.
15	PWR_RTN	Power Return	Return path for input power.
16	SER_DATA_OUT_H	Output RS-422	Asynchronous High
17	No Connect	N/A	N/A
18	SER_DATA_OUT_L	Output RS-422	Asynchronous Low
19-21	No Connect		
22	CAN_L	Bi-directional - ISO 11898-2	Can Bus Low
23	No Connect	No Connect	
24	CAN_H	Bi-directional - ISO 11898-2	Can Bus High

Mode and Communication Selection

The HG1120 supports the message protocols, data rates, and bandwidths, described in Table 2. The HG1120 can be configured by setting discrete inputs DIO1 through DIO4. These pins are only read upon reset or power up. State of the pins is shown in word 9 of the multiplexed status word.

The first frame of serial output data after power-application will contain a fixed pattern of 0x55s in place of sensor data. Subsequent frames of serial output data will contain compensated sensor data.

The control bandwidth in Table 2 describes the nominal -90° phase point. The -3dB frequency is nominally $2\times$ the -90° phase frequency. The bandwidth is exclusive of transmission delay.

Control data consists of the angular rates, linear acceleration, magnetic, and IMU status words in message set {0x04, 0x05} and set {0x0C, 0x0D}. The angular and linear data is filtered and sampled at 1800 Hz. The 1800 Hz filtered angular and linear data is decimated for 600 Hz control data.

The 300/100 Hz navigation data output consists of incremental (or “delta”) angles and velocities as shown in message IDs 0x05 and 0x0D. The navigation data is unfiltered 1800 Hz sensor data which is summed to the navigation data rate (300 Hz or 100 Hz). Accurate attitude and position calculations require that all messages be received and used.

Gyro and accelerometer residuals are calculated and carried forward to the next message for both navigation and control data. The serial output FIFO is loaded with the LS byte first and LS 16-bit word first. The sensor data (gyro, accelerometer, magnetometer, and temperature) are all signed 2's complement integers.

Table 2. Mode Selection

DIO4	DIO3	DIO2	DIO1	PROTOCOL	CONTROL/NAV. DATA RATES	CONTROL/INERTIAL MESSAGE FORMATS	CONTROL DATA BANDWIDTH (-90° PHASE POINT)
1	1	1	1	ASYN	1800/300 Hz	0x04/0x05	97 Hz Gyro 155 Hz Accelerometer
1	1	1	0	ASYN	600/100 Hz	0x0C/0x0D	
1	1	0	1	ASYN	600/100 Hz	0x0C/0x0D	90Hz
1	1	0	0	ASYN	600/100 Hz	0x0C/0x0D	50Hz
1	0	1	1	SPI	1800/300 Hz	0x04/0x05	97 Hz Gyro 155 Hz Accelerometer
1	0	1	0	SPI	600/100 Hz	0x0C/0x0D	
1	0	0	1	SPI	600/100 Hz	0x0C/0x0D	90Hz
1	0	0	0	SPI	600/100 Hz	0x0C/0x0D	50Hz
0	1	1	1	CAN2A	600/100 Hz	11 Bit ID	90Hz
0	1	1	0	CAN2A	600/100 Hz	11 Bit ID	50Hz
0	1	0	1	CAN2B	600/100 Hz	29 Bit ID	90Hz
0	1	0	0	CAN2B	600/100 Hz	29 Bit ID	50Hz
0	0	1	1	SPARE	NA	NA	NA
0	0	1	0	SPARE	NA	NA	NA
0	0	0	1	SPARE	NA	NA	NA
0	0	0	0	SPARE	NA	NA	NA

Asynchronous Protocol

The asynchronous 1800/300 Hz data protocol is as specified in Table 3 – Control Message (0x04) Format and Table 7 – Inertial Message (0x05) Format.

The asynchronous 600/100 Hz data protocol is as specified in Table 8 – Control Message (0x0C) Format and Table 9 – Inertial Message (0x0D) Format.

The transmit baud rate will be 1Mbits/sec with 1 start bit, 8 data bits, 1 stop bit, and no parity.

Table 3. Control Message (0x04 Data Format)

POSITION	PARAMETER	LENGTH (BYTES)	LSB WEIGHT	UNITS OR CONTENTS
1	IMU Address	1	N/A	Constant 0x0E
2	Message ID	1	N/A	Constant 0x04
3	Angular Rate X	2	$2^{-20} * 1800 * 2/3$	rad/sec/LSB
4	Angular Rate Y	2	$2^{-20} * 1800 * 2/3$	rad/sec/LSB
5	Angular Rate Z	2	$2^{-20} * 1800 * 2/3$	rad/sec/LSB
6	Linear Acceleration X	2	$2^{-14} * 1800 * 2/3$	0.3048 meters/sec ² /LSB
7	Linear Acceleration Y	2	$2^{-14} * 1800 * 2/3$	0.3048 meters/sec ² /LSB
8	Linear Acceleration Z	2	$2^{-14} * 1800 * 2/3$	0.3048 meters/sec ² /LSB
9	Mag Field X	2	0.438404	Milli-gauss/LSB
10	Mag Field Y	2	0.438404	Milli-gauss/LSB
11	Mag Field Z	2	0.438404	Milli-gauss/LSB
12	Main Status Word	2	N/A	See Table 4.
13	Multiplexed Status Word	2	N/A	See Table 5.
14	Checksum Sum of all message data (positions 1...13 of this table), taken as 16 bit words, and summed without regard for rollover.	2	N/A	// this pseudo code illustrates the checksum algorithm u16sum = 0; for (i=0; i<12; i++) // (26-2)/2=12 { u16sum += u16_msg_array[i]; } Checksum = u16_msg_array[12]; if (Checksum != u16sum) {checksum error}
Total Length		26		

Table 4. Main Status Word Definition

BIT(S)	PARAMETER	VALUES
0-3	Multiplexed Status Word Counter	See Table 5.
4	IMU OK	0=OK, 1=Failed
5	Sensor Board Initialization Successful	0=OK, 1=Failed
6	Accelerometer X Validity	0=OK, 1=Failed
7	Accelerometer Y Validity	0=OK, 1=Failed
8	Accelerometer Z Validity	0=OK, 1=Failed
9	Gyro X Validity	0=OK, 1=Failed
10	Gyro Y Validity	0=OK, 1=Failed
11	Gyro Z Validity	0=OK, 1=Failed
12	Magnetometer Validity	0=OK, 1=Failed
13	Power Up BIT Status (Latched)	0=OK, 1=Failed
14	Continuous BIT Status (Latched)	0=OK, 1=Failed
15	Power Up Test - Sets at start of serial data (~100 milliseconds) and clears before 300 milliseconds.	0=Normal, 1+Power Up Tests

Table 5. Multiplexed Status Word

MUX WORD COUNTER	CONTENTS (1.6 BITS)	UNITS
0	Software Version Number	Binary
1	Gyro and Accelerometer Status	See Table 6
2	Gyro and Accelerometer BIT History (Latched Until Power is Cycled or Unit is Reset)	Bits 3-8 of Mux Word Counter 1 will be latched if the individual BIT test counter reaches 15. The test counter is increased by 1 for a failure and then reduced by 1 if the failure clears. Bit 2 of Mux Word Counter 1 employs similar logic but the test counter limit is 5.
3	Magnetometer BIT Status	Bits 3-15 are Honeywell use only. 0=OK, 1=Failed, applies to remaining bits.
4	Reserved	Reserved
5	Processor/Memory BIT Status	See Table 7
6	Processor/Memory BIT Status (Latched Until Power is Cycled or Unit is Reset)	See Table 7
7	Accelerometer/Gyro Sensor Temperature	-0.0039 °C/LSB, Not Calibrated
8	Magnetometer Temperature	-0.0039 °C/LSB, Not Calibrated
9	DIO1-DIO4 Device Configuration Echo	Bit 0: DIO 1 Bit 1: DIO 2 Bit 2: DIO 3 Bit 3: DIO 4 Bit 4-15: reserved
10-15	Reserved	0

Table 6. Gyro and Accelerometer BIT Status

BIT(S)	PARAMETER	VALUES
0	Sensor Electronics	0=OK, 1=Failed
1	Sensor Data Ready	0=OK, 1=Failed
2	Temperature	0=OK, 1=Failed
3-5	Accelerometer X, Y, Z Health	0=OK, 1=Failed
6-8	Gyro X, Y, Z Health	0=OK, 1=Failed
9-15	Reserved	0=OK, 1=Failed

Table 7. Processor/Memory BIT Status Word

BIT(S)	PARAMETER	VALUES
0	Loop Completion Test	0=OK, 1=Failed
1	RAM Test	0=OK, 1=Failed
2	Coefficient Table CRC Test	0=OK, 1=Failed
3	Configuration Table CRC Test	0=OK, 1=Failed
4	Normal Mode SW CRC Test	0=OK, 1=Failed
5	Spare	0=OK, 1=Failed
6	Stack Overflow Test	0=OK, 1=Failed
7	Watchdog Timer Test	0=OK, 1=Failed
8	Processor Test	0=OK, 1=Failed
9-15	Reserved	N/A

Table 8. Inertial Message (0x05 Data Format)

POSITION	PARAMETER	LENGTH (BYTES)	LSB WEIGHT	UNITS OR CONTENTS
1	IMU Address	1	N/A	Constant 0x0E
2	Message ID	1	N/A	Constant 0x05
3-13	Control Data	22	N/A	Contents same as Message 0x04 Positions 3-13.
14	Delta Angle X	4	2^{-34}	radians/LSB or equivalently, radians/second/Hz/LSB
15	Delta Angle Y	4	2^{-34}	
16	Delta Angle Z	4	2^{-34}	
17	Delta Velocity X	4	2^{-28}	0.3048 meters/sec/LSB or equivalently, 0.3048 meters/sec ² /Hz/LSB
18	Delta Velocity Y	4	2^{-28}	
19	Delta Velocity Z	4	2^{-28}	
20	Checksum	2	N/A	// this pseudo code illustrates the checksum algorithm
	Sum of all message data (positions 1-19 of this table), taken as 16 bit words, and summed without regard for rollover.			u16sum = 0; for (i=0; i<24; i++) // (50-2)/2=24 { u16sum += u16_msg_array[i]; } Checksum = u16_msg_array[24]; if (Checksum != u16sum) {checksum error}
Total		50		

Table 9. Asynchronous Control Message (0x0C Data Format)

POSITION	PARAMETER	LENGTH (BYTES)	LSB WEIGHT	UNITS OR CONTENTS
1	IMU Address	1	N/A	Constant 0x0E
2	Message ID	1	N/A	Constant 0x0C
3	Angular Rate X	2	$2^{-20} * 600$	rad/sec/LSB
4	Angular Rate Y	2	$2^{-20} * 600$	rad/sec/LSB
5	Angular Rate Z	2	$2^{-20} * 600$	rad/sec/LSB
6	Linear Acceleration X	2	$2^{-14} * 600$	0.3048 meters/sec ² /LSB
7	Linear Acceleration Y	2	$2^{-14} * 600$	0.3048 meters/sec ² /LSB
8	Linear Acceleration Z	2	$2^{-14} * 600$	0.3048 meters/sec ² /LSB
9	Mag Field X	2	0.438404	Milli-gauss/LSB
10	Mag Field Y	2	0.438404	Milli-gauss/LSB
11	Mag Field Z	2	0.438404	Milli-gauss/LSB
12	Main Status Word	2	N/A	See Table 4
13	Detailed Multiplexed Status Word	2	N/A	See Table 5
14	Checksum	2	N/A	// this pseudo code illustrates the checksum algorithm
	Sum of all message data (positions 1-13 of this table), taken as 16 bit words, and summed without regard for rollover.			u16sum = 0; for (i=0; i<12; i++) // (26-2)/2=12 { u16sum += u16_msg_array[i]; } Checksum = u16_msg_array[12]; if (Checksum != u16sum) {checksum error}
Total Length		26		

Table 10. Asynchronous Inertial Message (0x0D Data Format)

POSITION	PARAMETER	LENGTH (BYTES)	LSB WEIGHT	UNITS OR CONTENTS
1	IMU Address	1	N/A	Constant 0x0E
2	Message ID	1	N/A	Constant 0x0D
3-13	Control Data	22	N/A	Contents same as Message 0x0C Positions 3-13.
14	Delta Angle X	4	2^{-33}	radians/LSB or equivalently, radians/second/Hz/LSB
15	Delta Angle Y	4	2^{-33}	
16	Delta Angle Z	4	2^{-33}	
17	Delta Velocity X	4	2^{-27}	0.3048 meters/sec/LSB or equivalently, 0.3048 meters/sec ² /Hz/LSB
18	Delta Velocity Y	4	2^{-27}	
19	Delta Velocity Z	4	2^{-27}	
20	Checksum	2	N/A	// this pseudo code illustrates the checksum algorithm
	Sum of all message data (positions 1-19 of this table), taken as 16 bit words, and summed without regard for rollover.			<pre> u16sum = 0; for (i=0; i<24; i++) // (50-2)/2=24 { u16sum += u16_msg_array[i]; } Checksum = u16_msg_array[24]; if (Checksum != u16sum) {checksum error} </pre>
Total		50		

SPI Protocol

The SPI 1800/300 Hz data protocol is as specified in Table 10 – SPI Control Message and Table 11 – Inertial Message.

The SPI 600/100 Hz data protocol is as specified in Table 12 – Control Message Format and Table 13 – SPI Inertial Message.

These messages are identical in content to the asynchronous HG1120 Control/Inertial messages except that Position 0 will be added and contain a 1 byte field containing the number of bytes of data (not including spare bytes) in the message.

The SPI clock frequency must be at least 2 MHz or no faster than 9 Mhz.

The SPI clock polarity and phase are set to one (1).

SPI data order is MSB first.

A 4-wire SPI implementation is used.

The DATA_RDY signal must be used to synchronize your application to the data being produced to ensure a consistent data set. The DATA_RDY signal must trigger an SPI fetch, and the clock rate must be fast enough to fetch an entire message within the Control data rate (either 1800 or 600 Hz).

The SPI_SS signal should be set, then the application should clock 408 (51*8) SPI bits before resetting the SPI_SS signal.

The External SPI device will be coming in asynchronous to the Control/Inertial message sequence. Each SPI message in the Control/Inertial set will be a constant length. The Control message will have spare bytes at the end, NOT included in the checksum, to match the length of the Inertial Message.

Table 11. SPI Control Message (0x04 Data Format)

POSITION	PARAMETER	LENGTH (BYTES)	LSB WEIGHT	UNITS OR CONTENTS
0	SPI Data Size	1	1	Number of bytes of data in message items 1..14 = 26
1-14	Control Data	26	N/A	See Message 0x04 Positions 1-14
15-20	Spare	24		None
Total Length		51		

Table 12. SPI Inertial Message (0x05 Data Format)

POSITION	PARAMETER	LENGTH (BYTES)	LSB WEIGHT	UNITS OR CONTENTS
0	SPI Data Size	1	1	Number of bytes of data in message items 1..20 = 50
1-20	Control and Navigation Data	50	N/A	See Inertial Message 0x05 Positions 1-20
Total Length		51		

Table 13. SPI Control Message (0x0C Data Format)

POSITION	PARAMETER	LENGTH (BYTES)	LSB WEIGHT	UNITS OR CONTENTS
0	SPI Message Data Size	1	1	Number of bytes of data in message items 1..14 = 26
1-14	Control Data	26	N/A	See Control Message 0x0C Positions 1-14
15-20	Spare	24	N/A	None
Total Length		51		

Table 14. SPI Inertial Message (0x0D Data Format)

POSITION	PARAMETER	LENGTH (BYTES)	LSB WEIGHT	UNITS OR CONTENTS
0	SPI Message Data Size	1	1	Number of bytes of data in message items 1..20 = 50
1-20	Control and Navigation Data	50	N/A	See Inertial Message 0x0D Format, Positions 1-20
Total Length		51		

CAN 2A/2B Protocol

The baud rate for all CAN messages will be 1Mbits/sec.

The software will place each entry of the Control and Inertial message onto the CAN Bus with the LS byte first and LS 16-bit word first.

Messages will be in sequence {(C1 C2 C3 I1 I2 I3) (C1 C2 C3) (C1 C2 C3) (C1 C2 C3) (C1 C2 C3) (C1 C2 C3)} – following the format of 5 consecutive control messages (C1 C2 C3), interleaved with one inertial message (C1 C2 C3 I1 I2 I3).

Table 15. CAN Control Message 1 Format

POSITION	PARAMETER	LENGTH (BYTES)	LSB WEIGHT	UNITS OR CONTENTS
n/a	Arbitration ID	n/a	n/a	11 bit = 0x0121 29 bit = 0x04924921
1	Angular Rate X	2	$2^{-20} * 600$	rad/sec/LSB
2	Angular Rate Y	2	$2^{-20} * 600$	rad/sec/LSB
3	Angular Rate Z	2	$2^{-20} * 600$	rad/sec/LSB
4	Main Status Word	2	N/A	See Table 4

Table 16. CAN Control Message 2 Format

POSITION	PARAMETER	LENGTH (BYTES)	LSB WEIGHT	UNITS OR CONTENTS
n/a	Arbitration ID	n/a	n/a	11 bit = 0x0122 29 bit = 0x04924922
1	Linear Acceleration X	2	$2^{-14} * 600$	0.3048 meters/sec ² /LSB
2	Linear Acceleration Y	2	$2^{-14} * 600$	0.3048 meters/sec ² /LSB
3	Linear Acceleration Z	2	$2^{-14} * 600$	0.3048 meters/sec ² /LSB
4	Detailed Multiplexed Status Word	2	N/A	See Table 5

Table 17. CAN Control Message 3 Format

POSITION	PARAMETER	LENGTH (BYTES)	LSB WEIGHT	UNITS OR CONTENTS
n/a	Arbitration ID	n/a	n/a	11 bit = 0x126 29 bit = 0x04924926
1	Mag Field X	2	0.438404	Milli-gauss/LSB
2	Mag Field Y	2	0.438404	Milli-gauss/LSB
3	Mag Field Z	2	0.438404	Milli-gauss/LSB

Table 18. CAN Inertial Message 1 Format

POSITION	PARAMETER	LENGTH (BYTES)	LSB WEIGHT	UNITS OR CONTENTS
n/a	Arbitration ID	n/a	n/a	11 bit = 0x123 29 bit = 0x04924923
1	Delta Angle X	4	2^{-33}	radians/LSB
2	Delta Velocity X	4	2^{-27}	0.3048 meters/sec/LSB

Table 19. CAN Inertial Message 2 Format

POSITION	PARAMETER	LENGTH (BYTES)	LSB WEIGHT	UNITS OR CONTENTS
n/a	Arbitration ID	n/a	n/a	11 bit = 0x124 29 bit = 0x04924924
1	Delta Angle Y	4	2^{-33}	radians/LSB
2	Delta Velocity Y	4	2^{-27}	0.3048 meters/sec/LSB

Table 20. CAN Inertial Message 3 Format

POSITION	PARAMETER	LENGTH (BYTES)	LSB WEIGHT	UNITS OR CONTENTS
n/a	Arbitration ID	n/a	n/a	11 bit = 0x125 29 bit = 0x04924925
1	Delta Angle Z	4	2^{-33}	radians/LSB
2	Delta Velocity Z	4	2^{-27}	0.3048 meters/sec/LSB

Mechanical Drawing and Installation

The accelerometer and gyro sensors are mounted in a normally aligned, right-handed axis configuration that is nominally aligned with the IMU axes as shown in the figure below. If the X axis is pointed up away from the Earth's surface, the accelerometer reading will be positive.

The HG1120 nominally weighs 54 grams.

This device has been designed to meet stringent EMI and EMC requirements, and as such, the user should shield the I/O cabling and provide chassis ground connection to the IMU housing.

IMUs are precision instruments which measure angular rate and linear acceleration across a broad temperature range. Because of their precision, users can interpret real motion (both angular and linear) as sensor noise. This noise can often be coupled mechanically through the mounting plate. Installation on a thin structure is generally not desirable. Placement at anti-nodes will minimize angular rotation and maximize linear displacement. Placement at nodes will maximize angular rotation and minimize linear displacement.

The IMU should not be subjected to contact with any fuels, lubricants, solvents, or their vapors.

A CAD compatible STP file is available from Honeywell upon request.

Recommended mating connectors are SAMTECH part numbers FLE-112-01-G-DV or CLP-112-02-F-D or equivalent.

The center of gravity and center of navigation are located at the approximate geometric center.

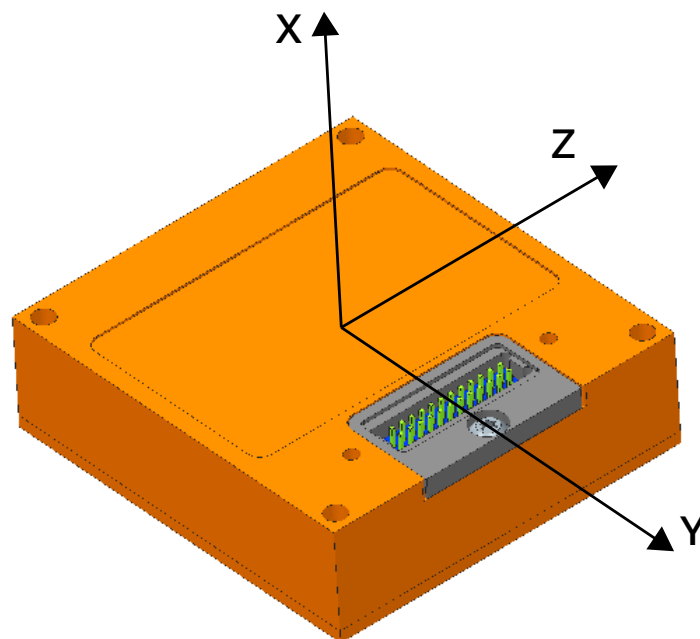

All dimensions are in millimeters

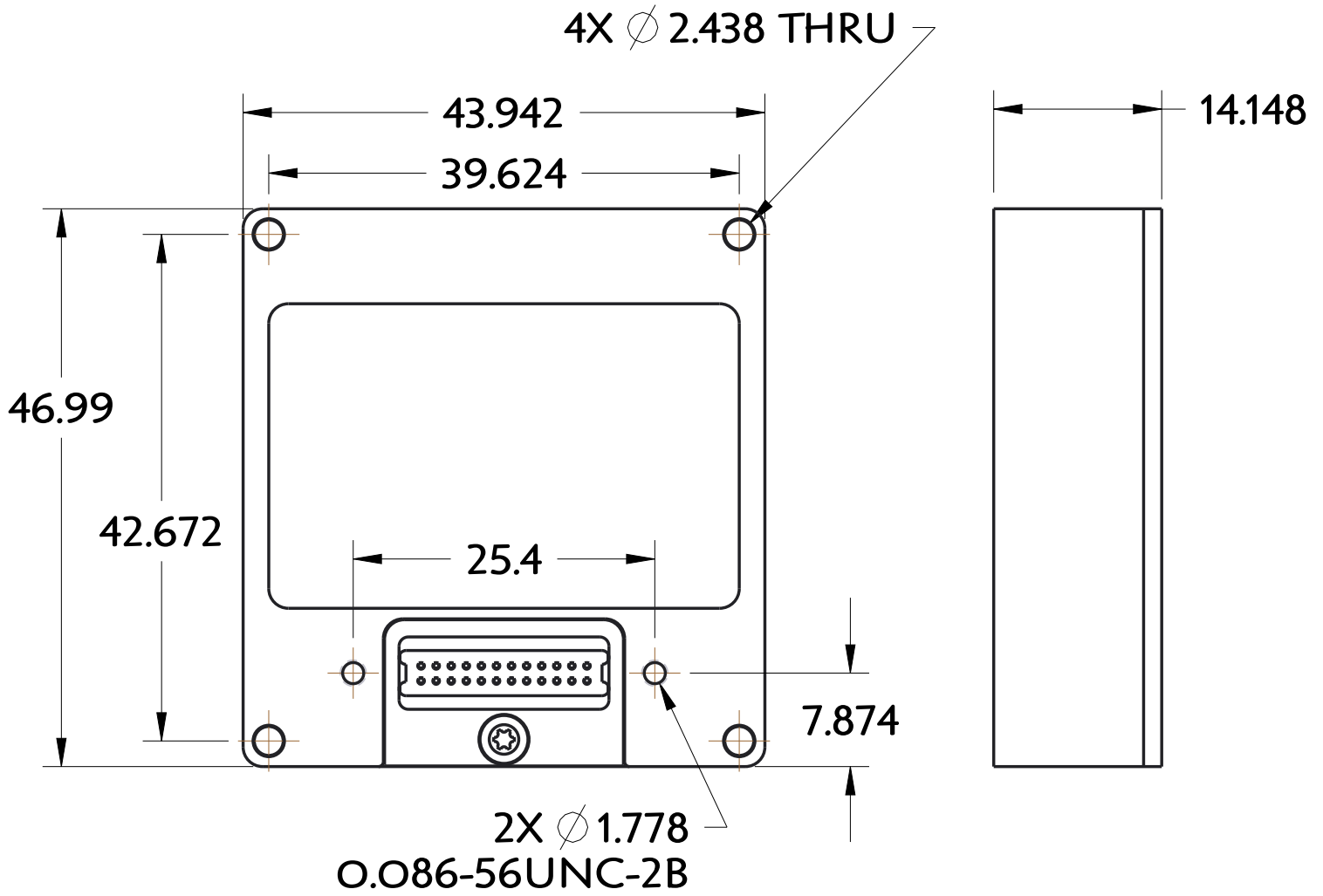

Export Guidance

All technology that leaves the United States is subject to export regulations. This manual contains technology that has an Export Commodity Classification of ECCN 7E994 with associated country chart control code of AT1. This technology generally will not require a license to be exported or re-exported. However, if you plan to export this item to an embargoed or sanctioned country, to a party of concern, or in support of a prohibited end-use, you may be required to obtain a license.

Contact Us

For more information, email imu.sales@honeywell.com
or contact us on our website aerospace.honeywell.com/HG1120

For more information

aerospace.honeywell.com/HG1120

Honeywell Aerospace

1944 East Sky Harbor Circle
Phoenix, Arizona 85034
+1 (800) 601 3099
aerospace.honeywell.com

N61-1774-000-000 | 06/17
© 2017 Honeywell International Inc.

Honeywell