





CODE 41 - LOW PROFILE HEAT SHRINK BOOT BACKSHELL

202M112-19B-

SERIES _____
 ORDER NUMBER (TABLE 1) _____
 MATERIAL _____
 REFER TO CH00-0250-004
 FINISH _____
 REFER TO CH00-0250-004
 MODIFICATION CODE _____
 REFER TO CH00-0250-004 (2)

NOTES:

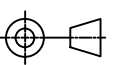
1. THIS PRODUCT IS DESIGNED TO TERMINATE A HEAT SHRINKABLE LIPPED BOOT TO A CONNECTOR.
- (2) FOR ADDITIONAL DIMENSIONS, ORDERING INFORMATION AND MODIFICATIONS, SEE CH00-0250-004.
3. ADAPTOR TO BE PERMANENTLY MARKED/BAGGED AND LABELLED WITH CODE IDENTIFICATION NUMBER AND PART NUMBER. (e.g. 06090-202M112-19B).
4. KNURL INSIDE BOOT GROOVE MAY BE SUPPLIED AT MANUFACTURER'S OPTION.
- (5) BACKSHELL MATES TO MIL-C-38999 SERIES I & II, CLASS E & T, MS27466, MS27467, MS27468, MS27472, MS27473, MS27474, MS27479, MS27480, MS27481, MS27484, MS27497, MS27652, MS27653, MS27656 CONNECTORS.

DRAWN	W.RUST	DATE 15/09/2015	 3RD ANGLE PROJECTION NOT TO SCALE	TITLE: LOW PROFILE, HEAT SHRINK BOOT BACKSHELL	 Polamco  <small>TE connectivity</small>
CHECKED		15/09/2015	UNLESS OTHERWISE SPECIFIED ALL DIMENSIONS IN MILLIMETRES GENERAL TOL LINEAR +/-0,25MM ANGULAR +/- 1°	ASSY USED ON:	
APPROVED	K.SHEPPARD	09/10/2015		MIL-DTL-38999 SERIES I & II	
APPROVED	H.SMITH	14/10/2015			
REVISIONS					
LTR	DESCRIPTION	DATE	APPROVED		
K	REVISED PER ECO-15-003650	03/06/15	I.MYONG		
L	REVISED PER ECO-15-013980	14/10/2015	H.SMITH		
TE CAGE CODE: 06090 POLAMCO/TE CAGE CODE: U5792				TE CONNECTIVITY - POLAMCO LTD RESERVES THE RIGHT TO AMEND THIS DRAWING AND THE INFORMATION SET FORTH HEREON AT ANY TIME. USERS SHOULD INDEPENDENTLY EVALUATE THE SUITABILITY OF THE PRODUCT FOR THEIR APPLICATION.	DRAWING NO: 202M1XX
				DRAWING REV: L	SHT 1

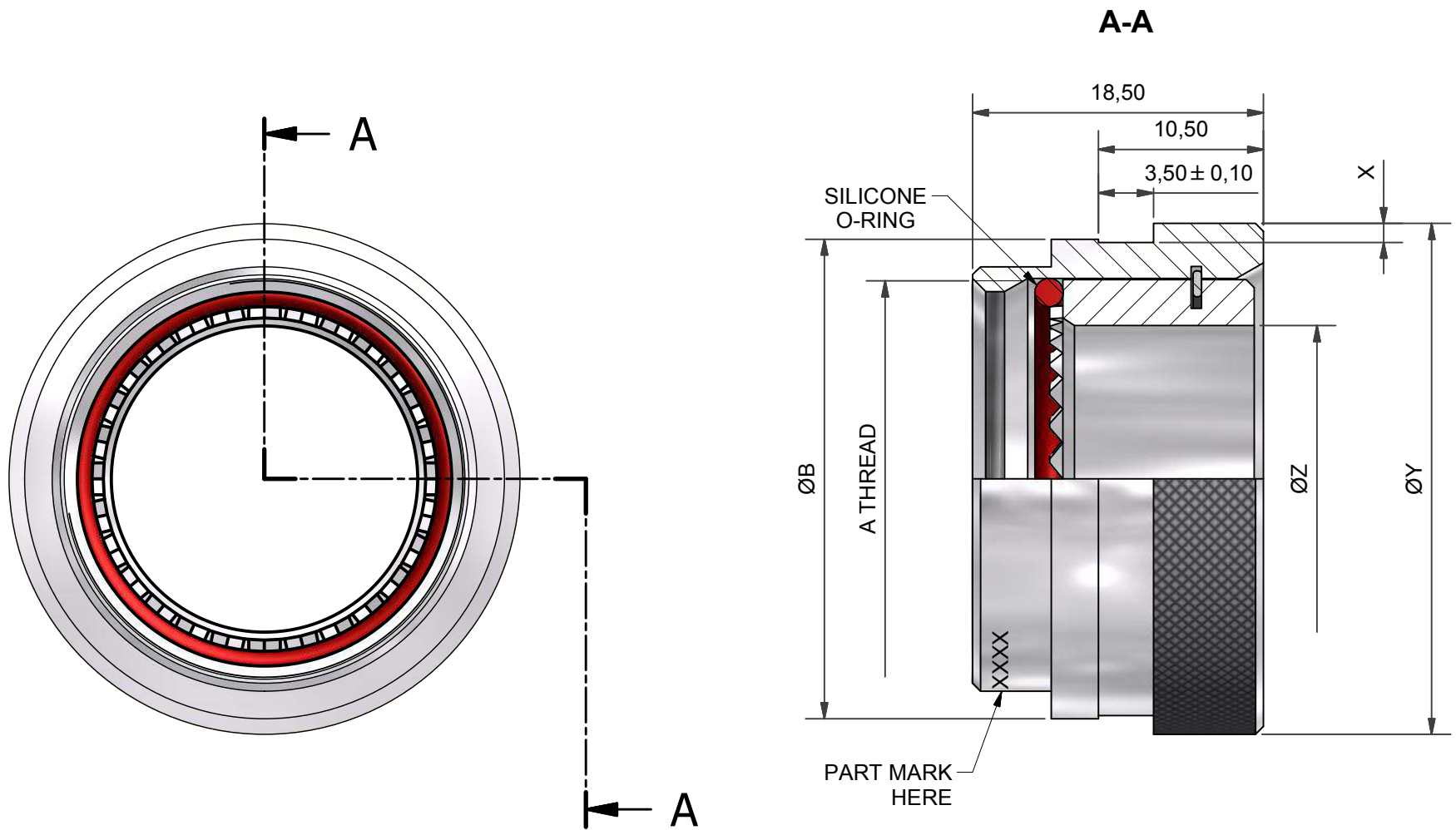
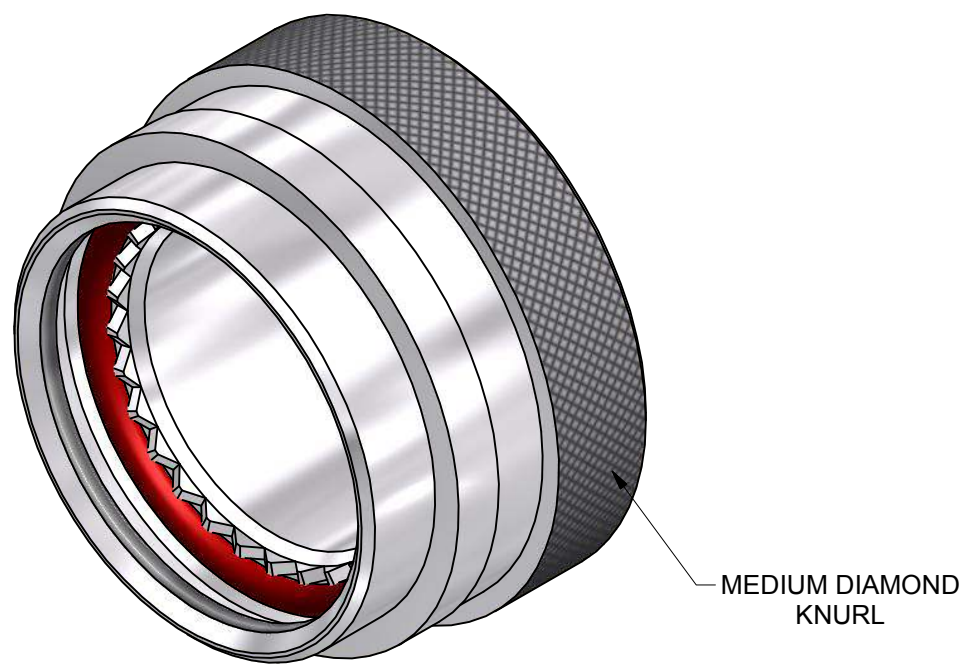

TABLE 1

BASE PART NUMBER	SHELL SIZE		A THREAD	ØB ± 0,2	X MIN	ØY MAX	ØZ ±0,15
	SER 1	SER 2					
202M108	9	8	7/16-28UNEF	17,5	1,2	18,0	6,8
202M110	11	10	9/16-24UNEF	20,5	1,2	21,5	10,3
202M112	13	12	11/16-24UNEF	23,5	1,2	24,5	13,1
202M114	15	14	13/16-20UNEF	25,5	1,2	27,5	16,3
202M116	17	16	15/16-20UNEF	30,5	1,2	32,5	19,5
202M118	19	18	1 1/16-18UNEF	33,5	1,2	35,5	21,9
202M120	21	20	1 3/16-18UNEF	36,5	1,8	38,5	25,1
202M122	23	22	1 5/16-18UNEF	40,0	1,8	42,0	28,3
202M124	25	24	1 7/16-18UNEF	43,0	1,8	45,0	31,5

DRAWN	W.RUST	DATE	15/09/2015	<p>3RD ANGLE PROJECTION NOT TO SCALE</p> <p>UNLESS OTHERWISE SPECIFIED ALL DIMENSIONS IN MILLIMETRES GENERAL TOL LINEAR +/-0,25MM ANGULAR +/- 1°</p>
CHECKED		DATE	15/09/2015	
APPROVED	K.SHEPPARD	DATE	09/10/2015	
APPROVED	H.SMITH	DATE	14/10/2015	
REVISIONS				
LTR	DESCRIPTION	DATE	APPROVED	
K	REVISED PER ECO-15-003650	03/06/15	I.MYONG	
L	REVISED PER ECO-15-013980	14/10/2015	H.SMITH	
TE CAGE CODE: 06090 POLAMCO/TE CAGE CODE: U5792				

TITLE:
LOW PROFILE, HEAT SHRINK BOOT BACKSHELL

ASSY USED ON:
MIL-DTL-38999 SERIES I & II

TE CONNECTIVITY - POLAMCO LTD RESERVES THE RIGHT TO AMEND THIS DRAWING AND THE INFORMATION SET FORTH HEREON AT ANY TIME. USERS SHOULD INDEPENDENTLY EVALUATE THE SUITABILITY OF THE PRODUCT FOR THEIR APPLICATION.

Polamco

TE connectivity

DRAWING NO:	DRAWING REV:	SHT
202M1XX	L	2