

DETAIL A

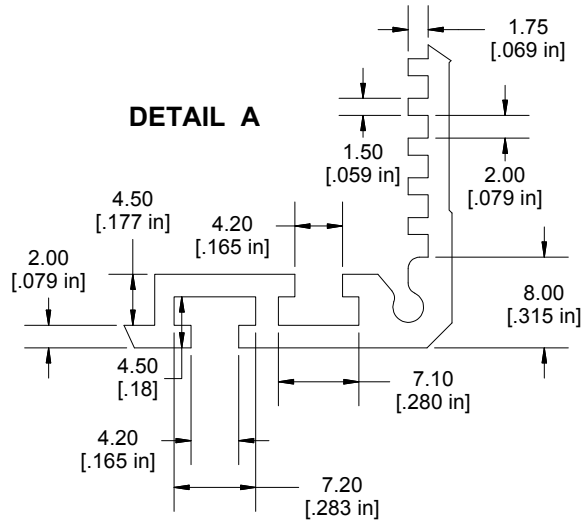

DETAIL B

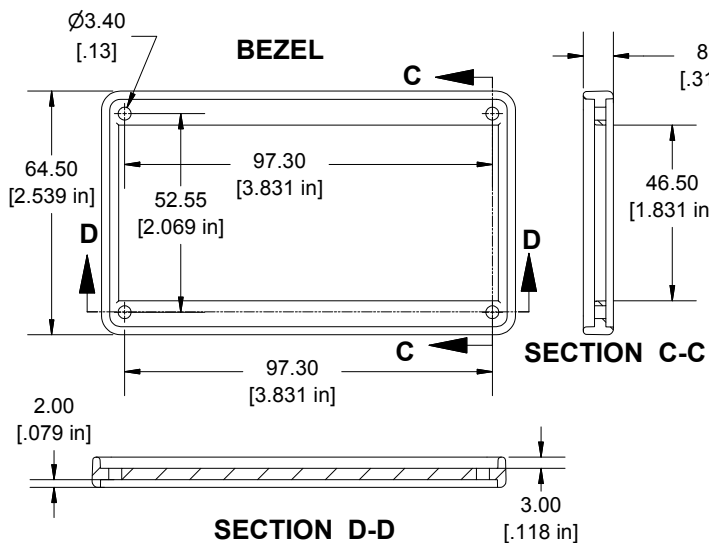
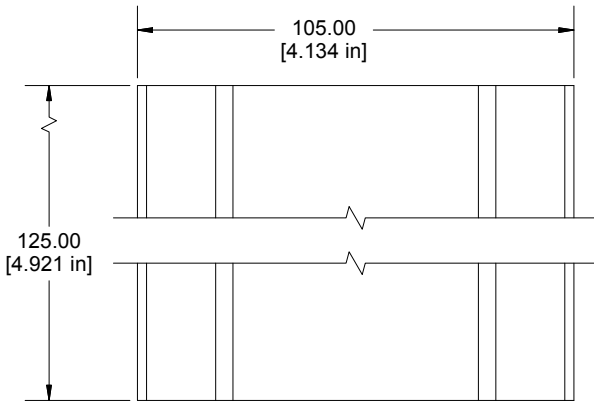
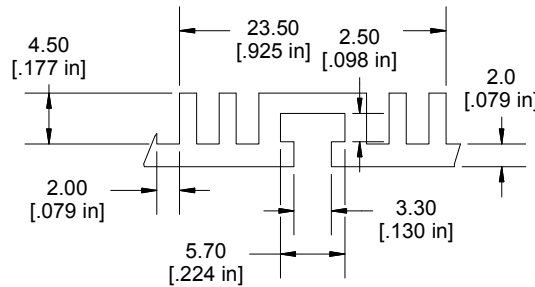

END PLATE

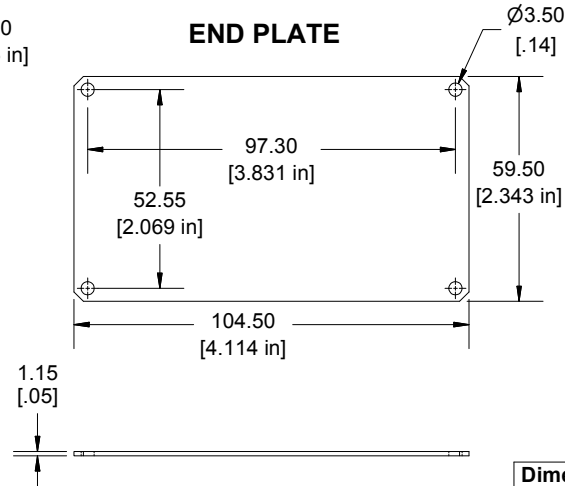

Enclosures can be Factory Modified (Milling, Drilling, Printing etc.)
 Contact Factory mjm@hammondmfg.com for quotes
 Solid models of this enclosure available in STEP or IGES.
 (Part number and text placement/orientation on our products are subject to change,
 we do not recommend using them as a locating reference for modification purposes)

NOTE	
Purchased assembly includes Extrusion, 2 End Plate, 2 Bezels and 8 screws	
Recommended Cover screw torque -- 2.5-3.5 lbf-in (30-40 cN-m)	

PART NUMBERS	
SINK BOX	
Extrusion Aluminum Alloy / Black Anodized	431611
Extrusion Aluminum Alloy / Clear Anodized	531611
ACCESSORIES	
End Plate Aluminum Alloy / Black Anodized	031624
End Plate Aluminum Alloy / Clear Anodized	131624

**HAMMOND
MANUFACTURING®**
SINK BOX
31611
www.hammondmfg.com

Dimensions:
 mm
 [inches]