

4

3

2

1

THIS DRAWING IS UNPUBLISHED.

RELEASED FOR PUBLICATION

REVISIONS

© COPYRIGHT - TE Connectivity Ltd.

ALL RIGHTS RESERVED.

P	LTR	DESCRIPTION	DATE	DWN	APVD
	A1	ECR-16-017266	31MAY2018	SR	PO

1. NO BURRS OR ROUGH EDGES PERMITTED AFTER MILLING.

- 2
- 3
- 4

BRASS
 BRIGHT NICKEL PLATE.
 MATTE NICKEL PLATE.

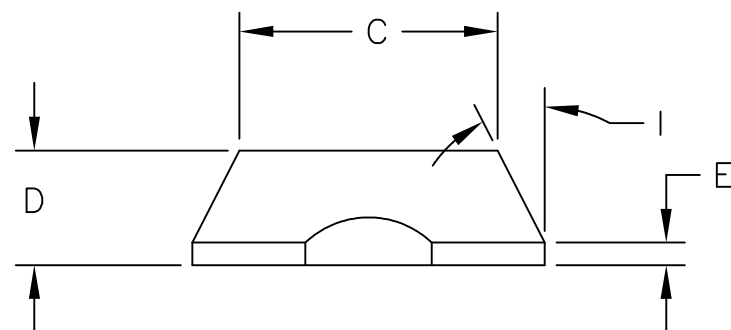
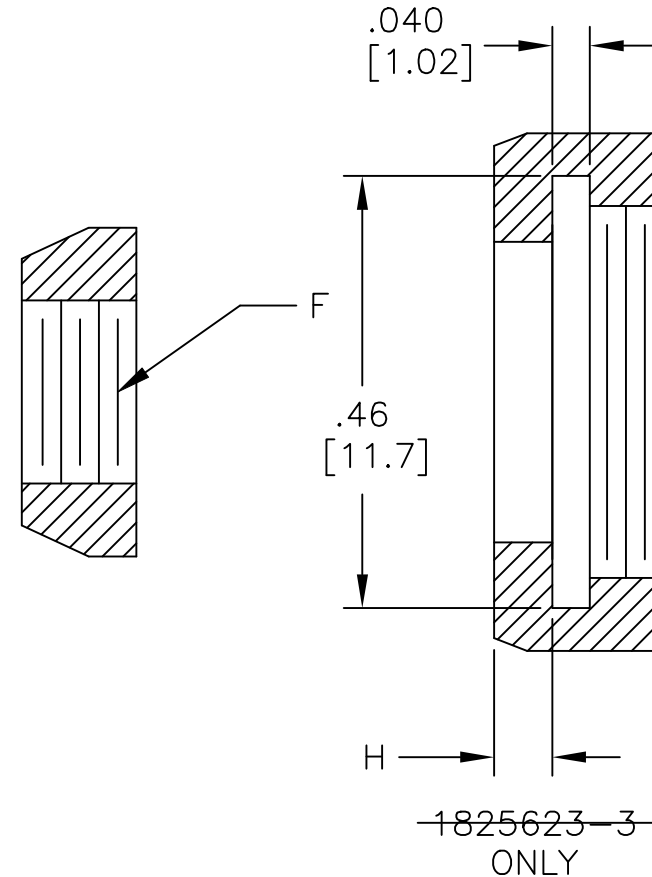
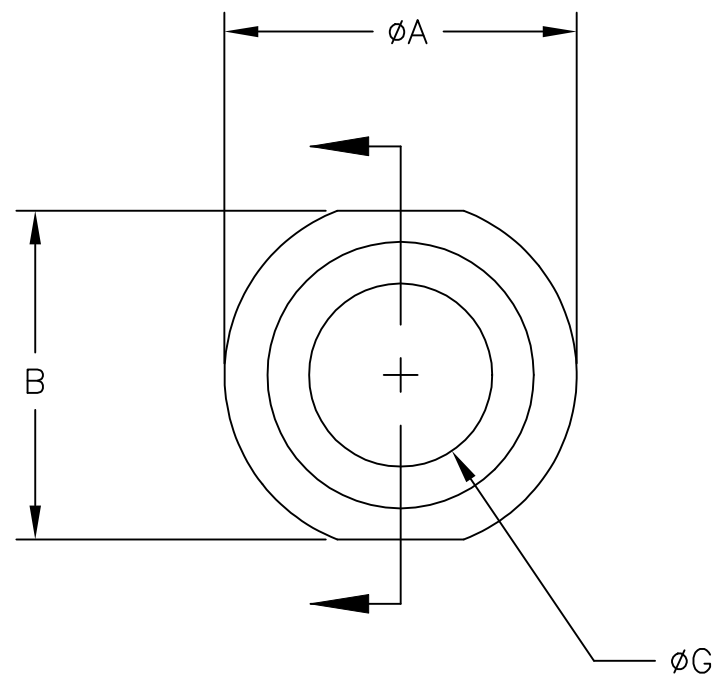

OBSOLETE	23* REF.	.062 [1.58]	.320 [8.13]	15/32-32 UNS 2B	.03 [0.8]	.170 [4.32]	.512 [13.01]	.551 ^{+0.000} _{-.005} [14.00 ^{+0.000} _{-0.13}]	.630 [16.00]	3	2	N45	1825623-3
	27* REF.		.195 [4.95]	1/4-40 UNS 2B	.02 [0.5]	.122 [3.10]	.275 [6.99]	.346 ^{+0.000} _{-.005} [8.79 ^{+0.000} _{-0.13}]	.375 [9.53]	3	2	N43	1825623-2
	27* REF.		.195 [4.95]	1/4-40 UNS 2B	.02 [0.5]	.122 [3.10]	.275 [6.99]	.346 ^{+0.000} _{-.005} [8.79 ^{+0.000} _{-0.13}]	.375 [9.53]	4	2	N40	1825623-1
	I	H	G	F	E	D	C	B	A	FINISH	MATERIAL	ALCO PART NUMBER	PART NUMBER

THIS DRAWING IS A CONTROLLED DOCUMENT.

DWN M.BINNER 30MAY2007

CHK M.WILBOURN 31MAY07

APVD M.WILBOURN 31MAY07

PRODUCT SPEC

APPLICATION SPEC

WEIGHT

CUSTOMER DRAWING

TE Connectivity Ltd.

NAME NUT, DECORATIVE

SIZE	CAGE CODE	DRAWING NO	RESTRICTED TO
A3	00779	C=1825623	-

DIMENSIONS: INCHES [mm]

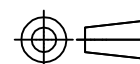

TOLERANCES UNLESS OTHERWISE SPECIFIED:

- 0 PLC ± -
- 1 PLC ± -
- 2 PLC ± .01[0.3]
- 3 PLC ± .005[0.13]
- 4 PLC ± -
- ANGLES ± -

MATERIAL SEE TABLE

FINISH SEE TABLE

SCALE 5:1

SHEET 1 of 1

REV A1