

THIS COPY IS PROVIDED ON A RESTRICTED BASIS AND IS NOT TO BE USED IN ANY WAY DETRIMENTAL TO THE INTERESTS OF PANDUIT CORP.

PANDUIT PART #	STUD SIZE		DIMENSIONS in. [mm]				
	ENGLISH	METRIC	L ± .03 [0,8]	W ± .01 [0,3]	C ± .02 [0,5]	M ± .03 [0,8]	H ± .01 [0,3]
PMNF1-3F*	--	M3	.83 [21,1]	.23 [5,8]	.20 [5,1]	.69 [17,5]	.13 [3,3]
PNF18-6F	#6	M3,5	.80 [20,3]	.30 [7,6]	.22 [5,6]	.66 [16,8]	.15 [3,8]
PNF18-8F	#8	M4	.86 [21,8]	.31 [7,9]	.25 [6,4]	.69 [17,5]	.17 [4,3]
PNF18-10F	#10	--	.87 [22,1]	.34 [8,6]	.26 [6,6]	.71 [18,0]	.20 [5,1]
PMNF1-5F*	--	M5	.90 [22,9]	.35 [8,9]	.25 [6,4]	.74 [18,8]	.21 [5,3]
PNF18-14F	1/4"	M6	1.05 [26,7]	.44 [11,2]	.35 [8,9]	.80 [20,3]	.27 [6,9]

\* NOT UL LISTED OR CSA CERTIFIED

NOTES:

- USED FOR:
  - #22-18 AWG [0,5-1,0 mm<sup>2</sup>] STRANDED COPPER WIRE
  - 221°F [105°C] MAX. OPERATING TEMPERATURE
  - 600V. MAX. BLDG WIRE (1000 V. MAX. IN SIGNS, FIXTURES & LUMINAIRES)
- INSTALLATION TOOLS:
  - UL APPROVED: CT-100A, CT-1550, CT-1551
  - PANDUIT APPROVED: CT-160, CT-260, CT-400, CT-460, CT-600A (CT-550CH), CT-2500 (CT-2550CH)
- WIRE STRIP LENGTH: 7/32" <sup>1/32</sup> [5,6 <sup>1/32</sup>]
- MATERIAL:
  - STAMPING: .03" [0,8] THK COPPER, TIN PLATED
  - HOUSING: NYLON, RED
  - SLEEVE: BRASS, TIN PLATED
- SEE [www.panduit.com](http://www.panduit.com) FOR PACKAGE QUANTITIES INDICATED BY PART NUMBER SUFFIX
- DIMENSIONS IN BRACKETS ARE METRIC EQUIVALENT

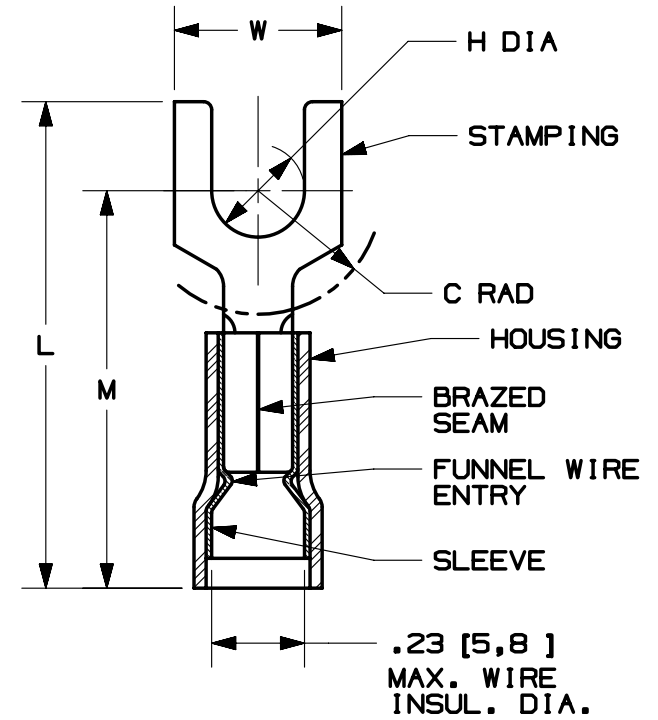

LISTED  
587H  
E52164



CERTIFIED  
LR31212

REV	DATE	BY	CHK	APR	DESCRIPTION	ECN
09	12.12.13	JHNU	JHNU	RGB	REVISED NOTE 2B: CT-550CH WAS CT-520CH, CT-2550CH WAS CT-2525	A41260
08	11.26.13	JHNU	TMR	RGB	INDICATED PART NUMBERS WHICH ARE NOT UL LISTED/CSA CERTIFIED	A41260
07	09.19.12	JBN	LCA	VMB	ADDED METRIC EQUIVALENT. REVISED NOTES. UPDATED TO CURRENT STANDARDS	A41260

TITLE <b>FORK, NYLON (FUNNEL) INSULATED #22-18</b> CUSTOMER DRAWING	
ITEM REVISION NAME N41260BA/09	<b>PANDUIT</b>
DATASET FILE NAME N41260BA_DC/09A	
UNLESS OTHERWISE SPECIFIED, DIMENSIONAL TOLERANCES ARE: IN [mm] .x ± .1 [2.54]    .xxx ± .005 [.13] .xx ± .01 [.25]    ANGLES ± 5°	
THIRD ANGLE PROJECTION	
DRAWING NUMBER: <b>A41260</b>	
DRAWN BY DAW	DATE -
CHK LA	SCALE N.T.S.
SHT 1 OF 1	
SIZE <b>A</b>	

15/0000A/15