

NOTES

1. MATERIAL : PHOSPHOR BRONZE
THICKNESS : 0.3mm
2. FINISH : NONE
3. APPLICABLE WIRE : 0.5 - 0.85mm²
4. RECOMMENDED LENGTH OF WIRE STRIP IS 3.2-3.8mm.
5. GENERAL TOLERANCE : ±0.3

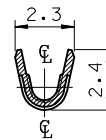

SEC' : A-A''

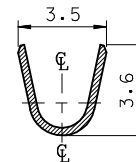

SEC' : B-B''

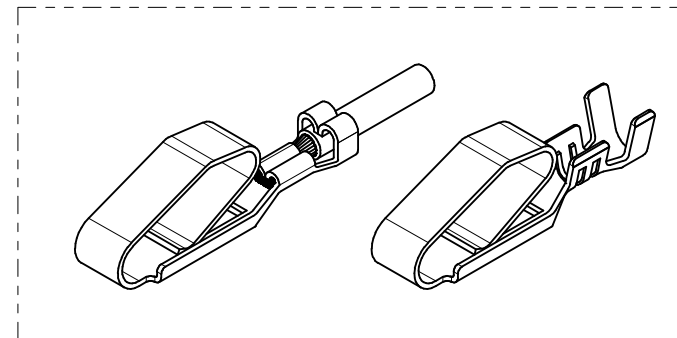
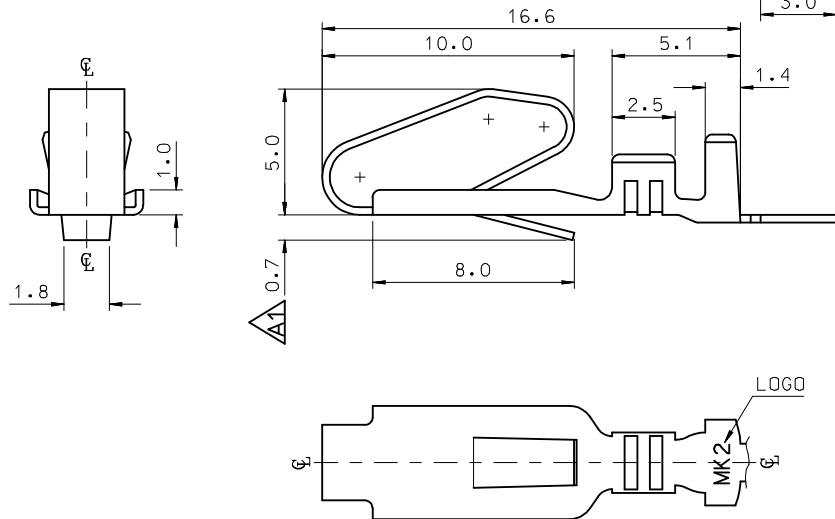

ISOMETRIC VIEW

CHANGED DIMENSION EC NO: KTR2015-0013 DRWN: YIBA EK 2014/09/12 CHKD: APPR: JYCH01 2014/09/22	DESCRIPTION A1	QUALITY SYMBOLS ▽=0 ◻=0	GENERAL TOLERANCES (UNLESS SPECIFIED)		DIMENSION STYLE		SCALE	DESIGN UNITS	THIRD ANGLE PROJECTION		
				mm	INCH	DRAWN BY	DATE	TITLE			
			4 PLACES	± ---	± ---	YIBA EK	2014/09/12	BULB SOCKET CONTACT TERMINAL			
			3 PLACES	± ---	± ---	CHECKED BY	DATE				
2 PLACES	± 0.15	± ---	APPROVED BY		DATE	MOLEX INCORPORATED					
1 PLACE	± 0.25	± ---	MATERIAL NO.		DATE					DOCUMENT NO.	
ANGULAR ± 2 °			DRAFT WHERE APPLICABLE MUST REMAIN WITHIN DIMENSIONS		35438-8000		SD-35438-001		1 OF 1		
					SIZE A3		THIS DRAWING CONTAINS INFORMATION THAT IS PROPRIETARY TO MOLEX INCORPORATED AND SHOULD NOT BE USED WITHOUT WRITTEN PERMISSION				