

Features

- 1-of-2 bidirectional translating multiplexer
- I2C-bus interface logic
- Operating power supply voltage: 1.65 V to 5.5 V
- Allows voltage level translation between 1.2V, 1.8V, 2.5 V, 3.3 V and 5 V buses
- Low standby current
- Low Ron switches
- Channel selection via I2C bus
- Power-up with all multiplexer channels deselected
- Capacitance isolation when channel disabled
- No glitch on power-up
- Supports hot insertion
- 5 V tolerant inputs
- 0 Hz to 400 kHz clock frequency
- ESD protection exceeds 8000 V HBM per JESD22-A114, and 1000 V CDM per JESD22-C101
- Latch-up testing is done to JEDEC Standard JESD78 which exceeds 100 mA
- Packages offered: SOIC-8W, MSOP-8U, TDFN2x3-8ZE

Description

The PI4MSD5V9540B is a 1-of-2 bidirectional translating multiplexer, controlled via the I2C bus

The SCL/SDA upstream pair fans out to two SCx/SDx downstream pairs, or channels. Only one

SCx/SDx channel is selected at a time, determined by the contents of the programmable control register.

A power-on reset function puts the registers in their default state and initializes the I2C bus state machine with no channels selected.

The pass gates of the multiplexer are constructed such that the VCC pin can be used to limit the maximum high voltage that is passed by the PI4MSD5V9540B. This allows the use of different bus voltages on each SCx/SDx pair, so that 1.2V, 1.8 V, 2.5 V or 3.3 V parts can communicate with 5 V parts without any additional protection. External pull-up resistors can pull the bus up to the desired voltage level for this channel. All I/O pins are 5 V tolerant.

Pin Configuration

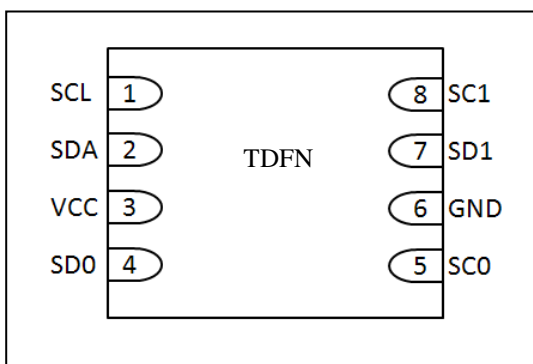
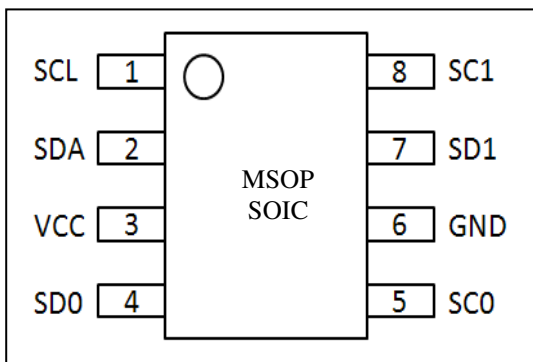

Pin Description

Pin No	Pin Name	Type	Description
1	SCL	I/O	serial clock line
2	SDA	I/O	serial data line
3	VCC	Power	supply voltage
4	SD0	I/O	serial data 0
5	SC0	I/O	serial clock 0
6	GND	GND	supply ground
7	SD1	I/O	serial data 1
8	SC1	I/O	serial clock 1

Block Diagram

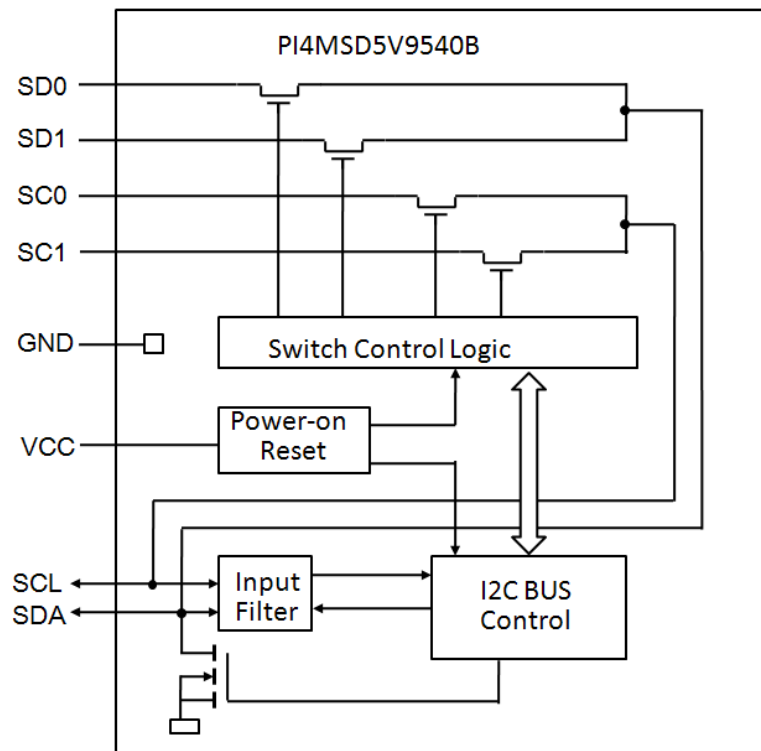

Figure 1: Block Diagram

Maximum Ratings

Storage Temperature	-55°C to +125°C
Supply Voltage port B	-0.5V to +6.0V
Supply Voltage port A	-0.5V to +6.0V
DC Input Voltage	-0.5V to +6.0V
Control Input Voltage (EN).....	-0.5V to +6.0V
Total power dissipation ⁽¹⁾	100mW
Input current(EN,VCCA,VCCB,GND).....	50mA
ESD: HBM Mode	8000V

Note:

Stresses greater than those listed under MAXIMUM RATINGS may cause permanent damage to the device. This is a stress rating only and functional operation of the device at these or any other conditions above those indicated in the operational sections of this specification is not implied. Exposure to absolute maximum rating conditions for extended periods may affect reliability.

Recommended operation conditions

Symbol	Parameter	Min	Typ	Max	Unit
V _{CC}	V _{CCA} Positive DC Supply Voltage	1.65	-	5.5	V
V _{EN}	Enable Control Pin Voltage	GND	-	5.5	V
V _{IO}	I/O Pin Voltage	GND	-	5.5	V
Δt / ΔV	Input transition rise or fall time	-	-	10	ns/V
T _A	Operating Temperature Range	-40	-	+85	°C

DC Electrical Characteristics

 Unless otherwise specified, $-40^{\circ}\text{C} \leq T_A \leq 85^{\circ}\text{C}$, $1.1\text{V} \leq V_{\text{CC}} \leq 3.6\text{V}$

Symbol	Parameter	Conditions	VCC	Min	Typ	Max	Unit
Supply							
VCC	Supply Voltage			1.65		5.5	V
ICC	supply current	operating mode; no load; $V_I = V_{\text{CC}}$ or GND; fSCL = 100 kHz	3.6V to 5.5V		65	100	uA
			2.3V to 3.6V		20	50	uA
			1.65V to 2.3V		10	30	uA
Istb	standby current	standby mode; VCC = 3.6 V; no load; $V_I = V_{\text{CC}}$ or GND; fSCL = 0 kHz	3.6V to 5.5V		0.3	1	uA
			2.3V to 3.6V		0.1	1	uA
			1.65V to 2.3V		0.1	1	uA
VPOR ^[1]	power-on reset voltage	no load; $V_I = V_{\text{CC}}$ or GND	3.6V to 5.5V		1.3	1.5	V
Input SCL; input/output SDA							
V _{IL}	LOW-level input voltage		1.65V to 5.5V	-0.5		+0.3V _{CC}	V
V _{IH}	HIGH-level input voltage		1.65V to 2V	0.75V _{CC}		6	V
			2V to 5.5V	0.7V _{CC}		6	V
I _{OL}	LOW-level output current	V _{OL} = 0.4 V	1.65V to 5.5V	3		-	mA
		V _{OL} = 0.6 V	1.65V to 5.5V	6		-	mA
I _{IL}	LOW-level input current	V _I = GND	1.65V to 5.5V	-1		+1	uA
I _{IH}	HIGH-level input current	V _I = VCC	1.65V to 5.5V	-1		+1	uA
Ci	input capacitance	V _I = GND	1.65V to 5.5V	-	9	10	pF
Pass Gate							
Ron	ON-state resistance	V _O = 0.4 V; I _O = 15 mA	4.5 V to 5.5 V	4	9	24	Ω
			3V to 3.6V	5	11	31	Ω
		V _O = 0.4 V; I _O = 10mA	2.3V to 2.7V	7	16	55	Ω
			1.65V to 2V	9	20	70	Ω
V _{pass}	switch output voltage	V _{in} = VCC; I _{out} = -100uA	5V		3.6		V
			4.5 V to 5.5 V	2.8		4.5	V
			3.3V		2.2		V
			3V to 3.6V	1.6		2.8	V
			2.5V		1.5		V
			2.3V to 2.7V	1.1		2	V
			1.8V		0.9		V
1.65V to 2V	0.54		1.3	V			
I _L	leakage current	V _I = VCC or GND	1.65V to 5.5V	-1		+1	uA
Cio	input/output capacitance	V _I = VCC or GND	1.65V to 5.5V		3	5	pF

Note: VCC must be lowered to 0.2 V for at least 5 us in order to reset part.

AC Electrical characteristics

Tamb = - 40 °C to +85 °C; unless otherwise specified.

Symbol	Parameter	Conditions	VCC	Min	Typ	Max	Unit
t _{PD} ^[1]	propagation delay	from SDA to SDx, or SCL to SCx	1.65V to 5.5V			0.3	ns

Note

[1] Pass gate propagation delay is calculated from the 20 Ω typical Ron and the 15 pF load capacitance.

I2C Interface Timing Requirements

Symbol	Parameter	STANDARD MODE I ² C BUS		FAST MODE I ² C BUS		UNIT
		MIN	MAX	MIN	MAX	
f _{scl}	I2C clock frequency	0	100	0	400	kHz
t _{Low}	I2C clock high time	4.7		1.3		μs
t _{High}	I2C clock low time	4		0.6		μs
t _{SP}	I2C spike time		50		50	ns
t _{SU:DAT}	I2C serial-data setup time	250		100		ns
t _{HD:DAT}	I2C serial-data hold time	0 ^[1]		0 ^[1]		μs
t _r	I2C input rise time		1000		300	ns
t _f	I2C input fall time		300		300	ns
t _{BUF}	I2C bus free time between stop and start	4.7		1.3		μs
t _{SU:STA}	I2C start or repeated start condition setup	4.7		0.6		μs
t _{HD:STA}	I2C start or repeated start condition hold	4		0.6		μs
t _{SU:STO}	I2C stop condition setup	4		0.6		μs
t _{VD:DAT}	Valid-data time (high to low) ^[2] SCL low to SDA output low valid		1		1	μs
	Valid-data time (low to high) ^[2] SCL low to SDA output high valid		0.6		0.6	μs
t _{VD:ACK}	Valid-data time of ACK condition ACK signal from SCL low to SDA output low		1		1	μs
C _b	I2C bus capacitive load		400		400	pF

Notes:

[1] A device internally must provide a hold time of at least 300 ns for the SDA signal (referred to as the VIH min of the SCL signal), in order to bridge the undefined region of the falling edge of SCL.

[2] Data taken using a 1-kΩ pull up resistor and 50-pF load Notes

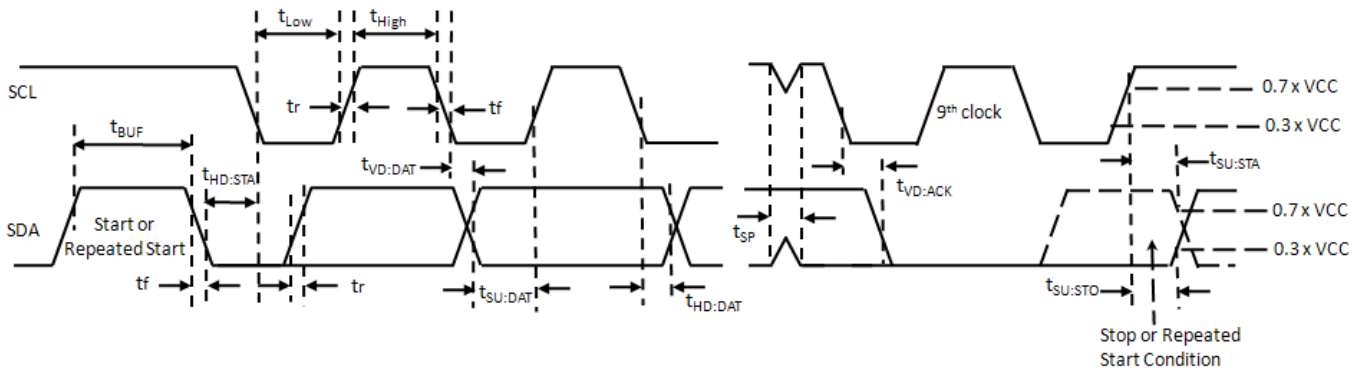

Figure 2. Definition of timing on the I2C-bus

Application

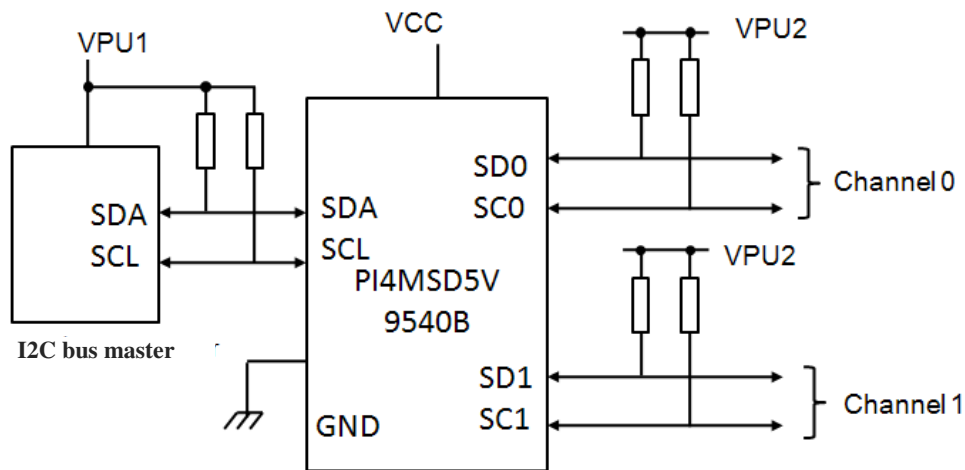

Figure 3. Typical Application

Recommended application voltage condition

VCC	VPU1	VPU2
1.8V	1.5V-5.5V	1.2V-5.5V
2.5V	1.8V-5.5V	1.8V-5.5V
3.3V	2.7V-5.5V	2.7V-5.5V
5V	4.5V-5.5V	4.5V-5.5V

Device addressing

Following a START condition the bus master must output the address of the slave it is accessing. The address of the PI4MSD5V9540B is shown in Figure 4.

The last bit of the slave address defines the operation to be performed. When set to logic 1 a read is selected, while a logic 0 selects a write operation.

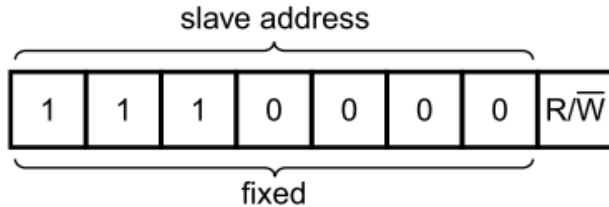

Figure 4: Device address

Control register

Following the successful acknowledgement of the slave address, the bus master sends a byte to the PI4MSD5V9540B which is stored in the Control register. If multiple bytes are received by the PI4MSD5V9540B, it saves the last byte received. This register can be written and read via the I2C-bus.

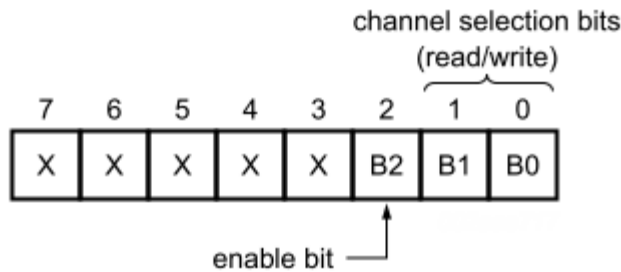

Figure 5: Control register

Control register definition

A SCx/SDx downstream pair, or channel, is selected by the contents of the Control register. This register is written after the PI4MSD5V9540B has been addressed.

The 2 LSBs of the control byte are used to determine which channel is to be selected. When a channel is selected, it will become active after a STOP condition has been placed on the I2C-bus. This ensures that all SCx/SDx lines are in a HIGH state when the channel is made active, so that no false conditions are generated at the time of connection.

D7	D6	D5	D4	D3	B2	B1	B0	Command
X	X	X	X	X	0	X	X	no channel selected
X	X	X	X	X	1	0	0	channel 0 enabled
X	X	X	X	X	1	0	1	channel 1 enabled
X	X	X	X	X	1	1	X	no channel selected
0	0	0	0	0	0	0	0	no channel selected; power-up default state

Control register: Write — channel selection; Read — channel status

Power-on reset

When power is applied to VCC, an internal Power-On Reset (POR) holds the PI4MSD5V9540B in a reset condition until VCC has reached VPOR. At this point, the reset condition is released and the PI4MSD5V9540B registers and I2C-bus state machine are initialized to their default states (all zeroes), causing all the channels to be deselected. Thereafter, VCC must be lowered below 0.2 V for at least 5 us in order to reset the device.

Voltage translation

The pass gate transistors of the PI4MSD5V9540B are constructed such that the VCC voltage can be used to limit the maximum voltage that is passed from one I2C-bus to another.

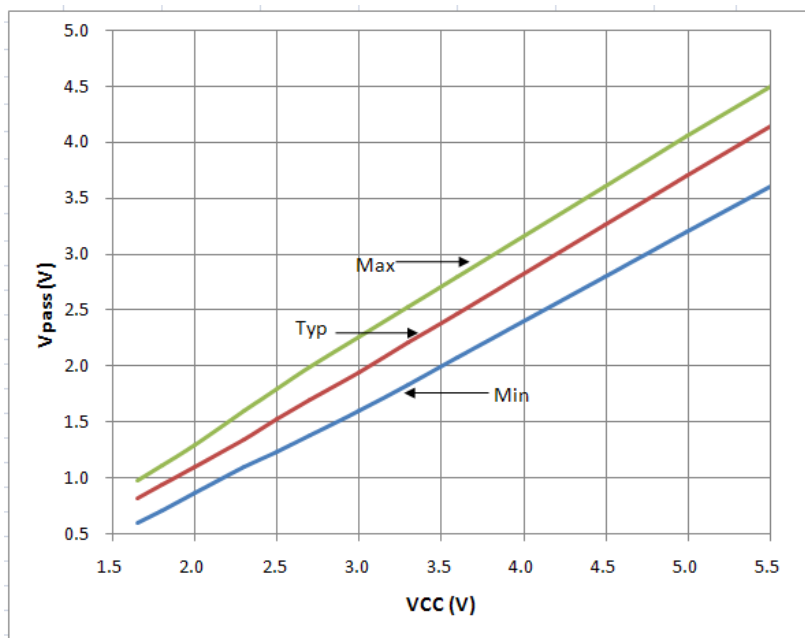

Figure 6: Vpass voltage VS Vcc

Figure 6 shows the voltage characteristics of the pass gate transistors (note that the graph was generated using the data specified in Section “DC Electrical characteristics” of this data sheet).

In order for the PI4MSD5V9540B to act as a voltage translator, the Vpass voltage should be equal to, or lower than the lowest bus voltage. For example, if the main bus was running at 5 V, and the downstream buses were 3.3 V and 2.7 V, then Vpass should be equal to or below 2.7 V to clamp the downstream bus voltages effectively.

Looking at Figure 6, we see that Vpass (max) is at 2.7 V when the PI4MSD5V9540B supply voltage is 3.5 V or lower so the PI4MSD5V9540B supply voltage could be set to 3.3 V. Pull-up resistors can then be used to bring the bus voltages to their appropriate levels

I2C BUS

The I2C-bus is for 2-way, 2-line communication between different ICs or modules. The two lines are a serial data line (SDA) and a serial clock line (SCL). Both lines must be connected to a positive supply via a pull-up resistor when connected to the output stages of a device. Data transfer may be initiated only when the bus is not busy.

One data bit is transferred during each clock pulse. The data on the SDA line must remain stable during the HIGH period of the clock pulse as changes in the data line at this time are interpreted as control signals

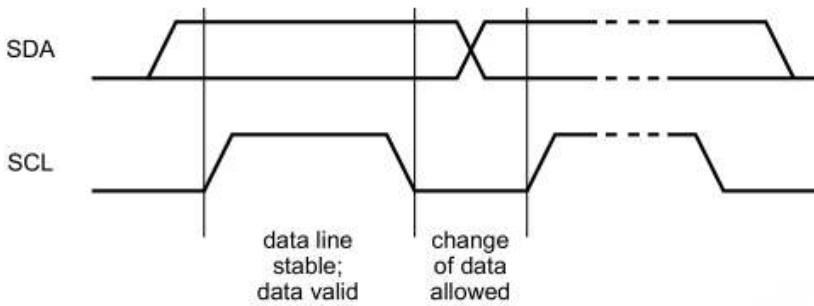

Figure 7: Bit Transfer

Both data and clock lines remain HIGH when the bus is not busy. A HIGH-to-LOW transition of the data line while the clock is HIGH is defined as the START condition (S). A LOW-to-HIGH transition of the data line while the clock is HIGH is defined as the STOP condition (P)

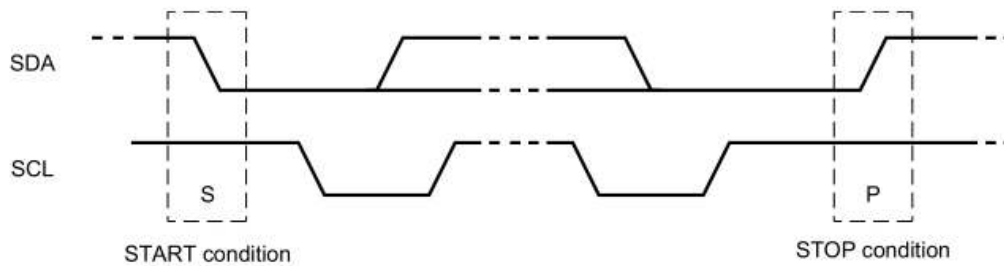

Figure 8. Definition of Start and Stop Conditions

A device generating a message is a 'transmitter', a device receiving is the 'receiver'. The device that controls the message is the 'master' and the devices which are controlled by the master are the 'slaves'

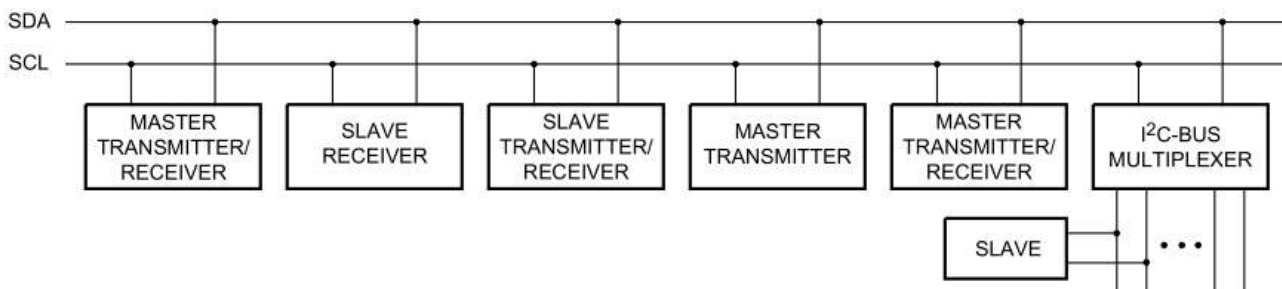

Figure 9. System Configuration

The number of data bytes transferred between the START and the STOP conditions from transmitter to receiver is not limited. Each byte of 8 bits is followed by one acknowledge bit. The acknowledge bit is a HIGH level put on the bus by the transmitter, whereas the master generates an extra acknowledge related clock pulse.

A slave receiver which is addressed must generate an acknowledge after the reception of each byte. Also, a master must generate an acknowledge after the reception of each byte that has been clocked out of the slave transmitter. The device that acknowledges has to pull down the SDA line during the acknowledge clock pulse so that the SDA line is stable LOW during the HIGH period of the acknowledge related clock pulse; set-up and hold times must be taken into account.

A master receiver must signal an end of data to the transmitter by not generating an acknowledge on the last byte

that has been clocked out of the slave. In this event, the transmitter must leave the data line HIGH to enable the master to generate a STOP condition.

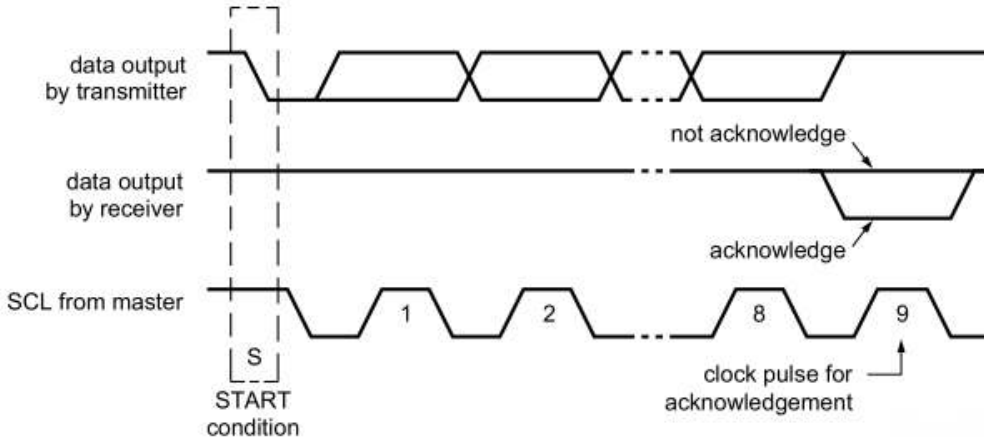

Figure 10. Acknowledgment on I2C Bus

Data is transmitted to the PI4MSD5V9540B control register using the write mode shown in bellow

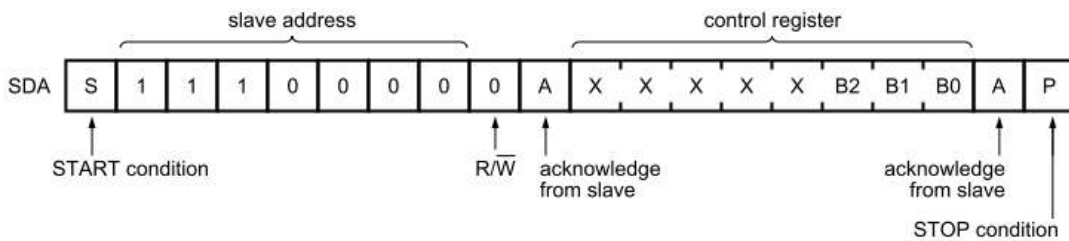

Figure 11. Write Control Register

Data is transmitted to the PI4MSD5V9540B control register using the write mode shown in bellow

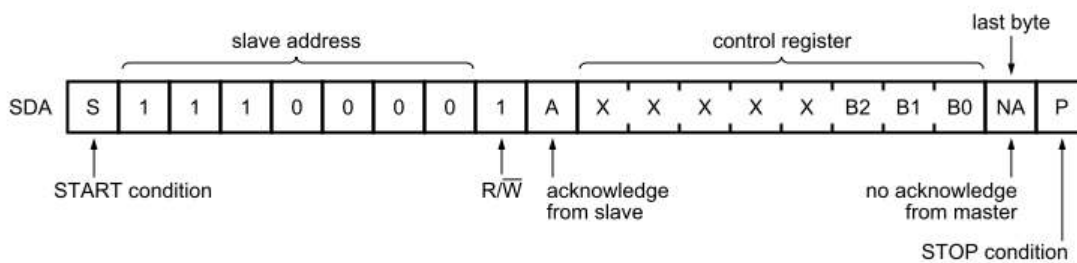
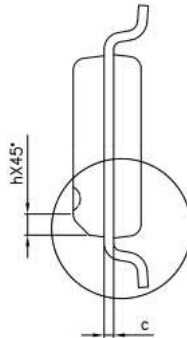
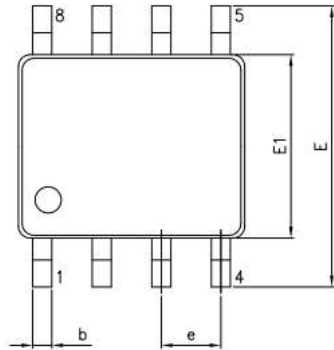

Figure 12. Read Control Register

Mechanical Information
SOIC-8(W)



SYMBOLS	MIN.	NOM.	MAX.
A	—	—	1.75
A1	0.10	—	0.25
A2	1.25	—	—
b	0.31	—	0.51
c	0.10	—	0.25
D	4.80	4.90	5.00
E	5.80	6.00	6.20
E1	3.80	3.90	4.00
e	1.27 BSC		
L	0.40	—	1.27
h	0.25	—	0.50
θ°	0	—	8

UNIT : mm

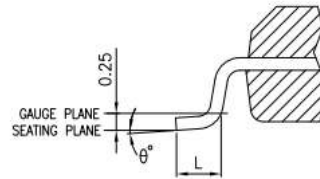
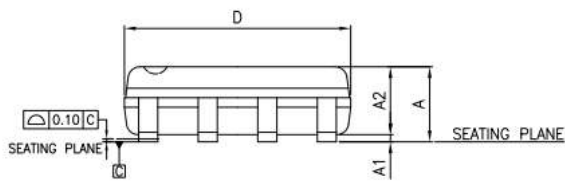

NOTE :
1. ALL DIMENSIONS ARE IN mm, ANGLES IN DEGREES
2. DIMENSIONS EXCLUDE BURRS, MOLD FLASH OR PROTRUSIONS
3. REFER JEDEC MS-012

PERICOM Enabling Serial Connectivity	DATE: 02/21/14
DESCRIPTION: 8-Pin, 150mil-Wide, SOIC	
PACKAGE CODE: W (W8)	
DOCUMENT CONTROL #: PD-1001	REVISION: G

MSOP-8(U)

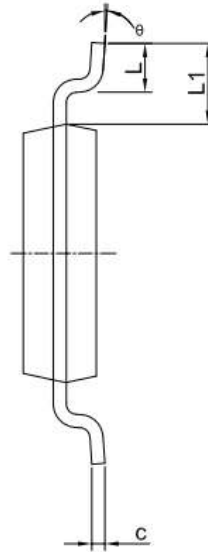
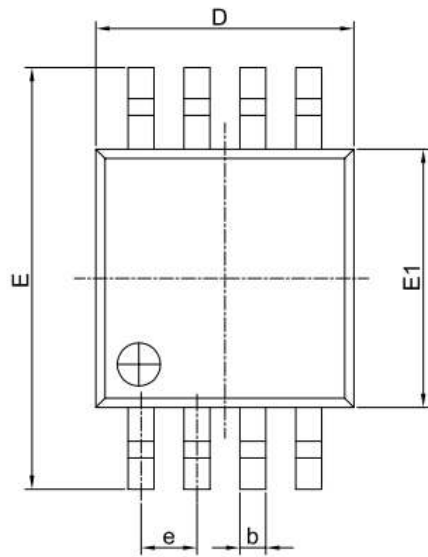

PKG DIMENSIONS(MM)		
SYMBOL	Min.	Max.
A	-	1.10
A1	0.00	0.15
A2	0.75	0.95
b	0.22	0.38
c	0.08	0.23
D	2.80	3.20
E	4.65	5.15
E1	2.80	3.20
e	0.65 BSC	
L	0.40	0.80
L1	0.95 REF	
θ	0°	8°

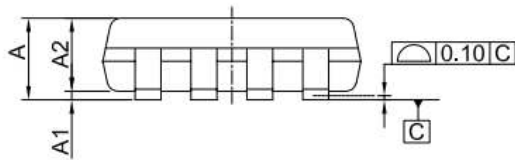

NOTE:

1. ALL DIMENSIONS ARE IN MILLIMETERS. ANGLES IN DEGREES.
2. REFER JEDEC MO-187F/AA
3. PACKAGE OUTLINE DIMENSIONS DO NOT INCLUDE MOLD FLASH AND METAL BURR.

DIODES INCORPORATED	PERICOM A PRODUCT LINE OF DIODES INCORPORATED ENABLING SERIAL CONNECTIVITY	DATE: 11/03/16
DESCRIPTION: 8-Pin, MInI Small Outline Package, MSOP		
PACKAGE CODE: U (U8)		
DOCUMENT CONTROL #: PD-1261	REVISION: G	

TDFN-8(ZE)

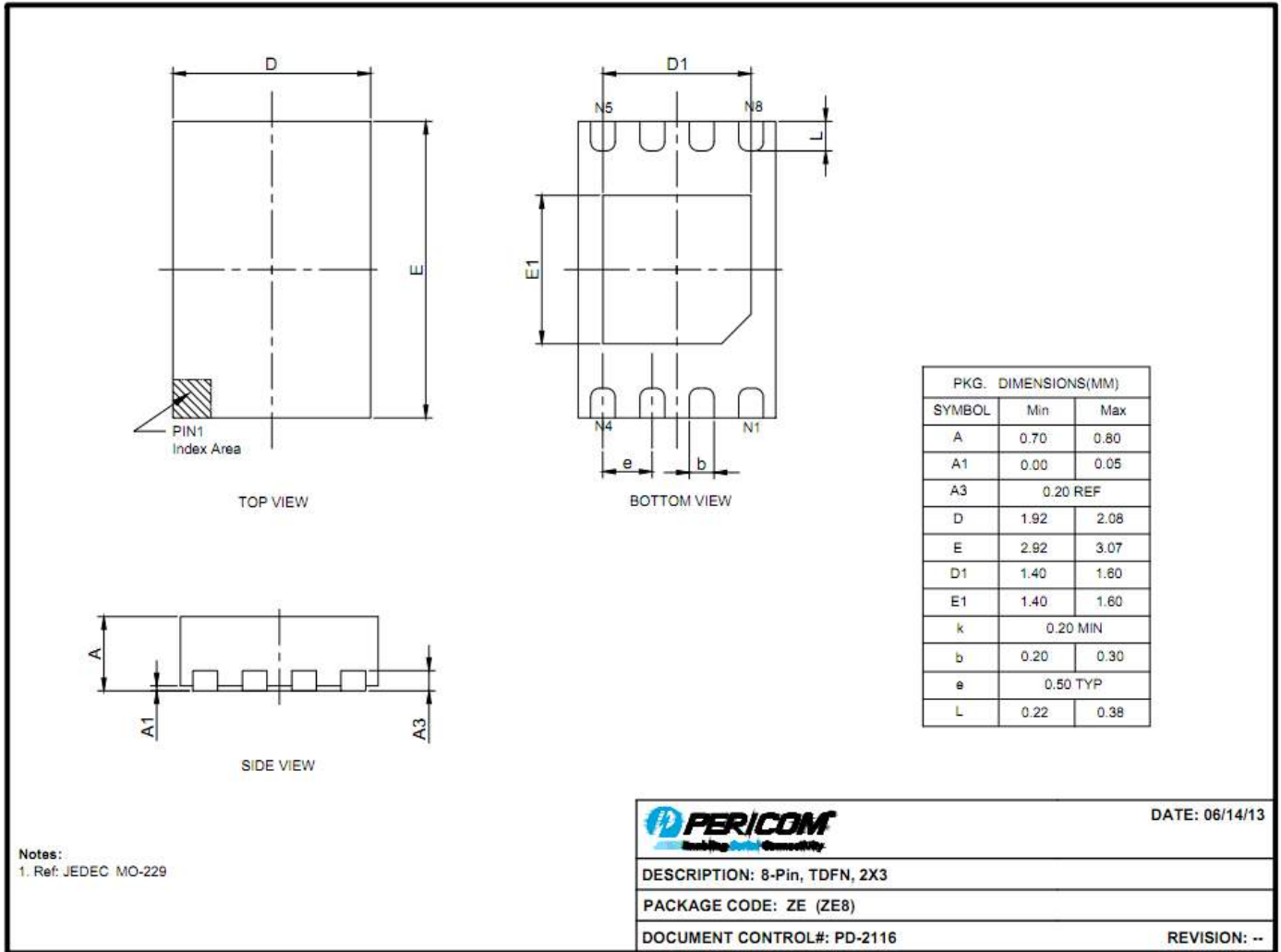

Ordering Information

Part No.	Package Code	Package
PI4MSD5V9540BWE	W	8-Pin, 150 mil Wide (SOIC)
PI4MSD5V9540BWEX	W	8-Pin, 150 mil Wide (SOIC_, Tape & Reel
PI4MSD5V9540BUE	U	8-Pin, Mini Small Outline Package (MSOP)
PI4MSD5V9540BUEX	U	8-Pin, Mini Small Outline Package (MSOP), Tape & Reel
PI4MSD5V9540BZEEX	ZE	8-Pin, 2x3 (TDFN), Tape & Reel

Note:

- Thermal characteristics can be found on the company web site at www.pericom.com/packaging/
- E = Pb-free and Green
- X suffix = Tape/Reel55

IMPORTANT NOTICE

DIODES INCORPORATED MAKES NO WARRANTY OF ANY KIND, EXPRESS OR IMPLIED, WITH REGARDS TO THIS DOCUMENT, INCLUDING, BUT NOT LIMITED TO, THE IMPLIED WARRANTIES OF MERCHANTABILITY AND FITNESS FOR A PARTICULAR PURPOSE (AND THEIR EQUIVALENTS UNDER THE LAWS OF ANY JURISDICTION).

Diodes Incorporated and its subsidiaries reserve the right to make modifications, enhancements, improvements, corrections or other changes without further notice to this document and any product described herein. Diodes Incorporated does not assume any liability arising out of the application or use of this document or any product described herein; neither does Diodes Incorporated convey any license under its patent or trademark rights, nor the rights of others. Any Customer or user of this document or products described herein in such applications shall assume all risks of such use and will agree to hold Diodes Incorporated and all the companies whose products are represented on Diodes Incorporated website, harmless against all damages.

Diodes Incorporated does not warrant or accept any liability whatsoever in respect of any products purchased through unauthorized sales channel.

Should Customers purchase or use Diodes Incorporated products for any unintended or unauthorized application, Customers shall indemnify and hold Diodes Incorporated and its representatives harmless against all claims, damages, expenses, and attorney fees arising out of, directly or indirectly, any claim of personal injury or death associated with such unintended or unauthorized application.

Products described herein may be covered by one or more United States, international or foreign patents pending. Product names and markings noted herein may also be covered by one or more United States, international or foreign trademarks.

This document is written in English but may be translated into multiple languages for reference. Only the English version of this document is the final and determinative format released by Diodes Incorporated.

LIFE SUPPORT

Diodes Incorporated products are specifically not authorized for use as critical components in life support devices or systems without the express written approval of the Chief Executive Officer of Diodes Incorporated. As used herein:

A. Life support devices or systems are devices or systems which:

1. are intended to implant into the body, or
2. support or sustain life and whose failure to perform when properly used in accordance with instructions for use provided in the labeling can be reasonably expected to result in significant injury to the user.

B. A critical component is any component in a life support device or system whose failure to perform can be reasonably expected to cause the failure of the life support device or to affect its safety or effectiveness.

Customers represent that they have all necessary expertise in the safety and regulatory ramifications of their life support devices or systems, and acknowledge and agree that they are solely responsible for all legal, regulatory and safety-related requirements concerning their products and any use of Diodes Incorporated products in such safety-critical, life support devices or systems, notwithstanding any devices- or systems-related information or support that may be provided by Diodes Incorporated. Further, Customers must fully indemnify Diodes Incorporated and its representatives against any damages arising out of the use of Diodes Incorporated products in such safety-critical, life support devices or systems.

Copyright © 2016, Diodes Incorporated
www.diodes.com

