

## Product Specification for Reference Only

Issued Date: April 30, 2015  
Rev.: N

Part Description: Ultrasonic Transducer

MURATA Part No.: MA40S4R

The product specification in this sheet is for reference only. The contents of this specification are subject to change.

You are requested to receive the latest specification and to return one copy of the specification to us with your receipt signature before going into mass production.

Sensor products department 1  
Sensor products division  
Murata Manufacturing Co., Ltd.

## Reference specification of Ultrasonic Transducer Type: MA40S4R

### 1. Scope

This product specification is applied to the Receiver of Ultrasonic Transducer (Open Type Structure).

### 2. Customer Part Number

### 3. Murata Part Number

**MA40S4R**

### 4. Structure

Dimension : As per Fig.1

### 5. Absolute Maximum Ratings

	Items	Specification	Note
5-1	Operating temperature range	-40 to +85 degC	-
5-2	Storage temperature range	-40 to +85 degC	-

### 6. Specifications (\* Temperature 25 ± 3°C, 45 to 75 % R.H, unless otherwise noted)

	Items	Specification	Note
6-1	Operating Frequency	40.0 kHz	For reference
6-2	Sensitivity	-63 dB +/- 3 dB	at 40 kHz / 0 dB = 10 V/Pa (per measuring circuit Fig.2)
6-3	Capacitance	2,550 pF +/- 20 %	at 1 kHz
6-4	Insulation Resistance	More than 100 Mohm	at 50 V D.C.
6-5	Temperature Characteristics	Within +/- 3dB against initial value at 25 degC	-40 to +85 degC

## 7. Environmental tests (Standard Test Condition: 25 +/- 3 degC, 45 to 75 %R.H)

### 7.1 Shock Test

The variation of the sensitivity at 40 kHz is within +/-3 dB compared with initial stage at 25 degC after applied following test conditions

Acceleration	:	sine 980 m/s <sup>2</sup> (100 G), 6 ms
Direction	:	3 directions
Shock time	:	3 times / directions

### 7.2 Vibration Test

The variation of the sensitivity at 40 kHz is within +/-3 dB compared with initial stage at 25 degC after applied following test conditions

Vibration frequency	:	10 to 55 Hz
Sweep Period	:	1 min.
Amplitude	:	1.5 mm
Directions	:	3 directions
Time	:	2 hours / direction

### 7.3 Resistance to Soldering Heat

The variation of the sensitivity at 40 kHz is within +/-3 dB compared with Initial stage at 25 degC in 1hour after touching soldering iron (Iron temperature : 350 degC), 3 seconds with the terminal. (Touching point must be 2mm or more away from the transducer body.)

### 7.4 High Temperature Test

The variation of the sensitivity at 40 kHz is within +/-3 dB compared with initial stage at 25 degC in 24 hours after applied following test conditions

Temperature	:	+85 +/-2 degC
Time	:	100 hours

### 7.5 Low Temperature Test

The variation of the sensitivity at 40 kHz is within +/-3 dB compared with initial stage at 25 degC in 24 hours after applied following test conditions

Temperature	:	-40 +/- 2 degC
Time	:	100 hours

### 7.6 Humidity Test

The variation of the sensitivity at 40 kHz is within +/-3 dB compared with initial stage at 25 degC in 24 hours after following test conditions

Temperature	:	+60 +/-2 degC
Humidity	:	90 to 95 %R.H.
Time	:	100 hours

### 7.7 Pull Strength

There should be no substantial damage until 9.8 N pulling force.

## 8. Caution

### 8-1 Limitation of Applications

Please do not use in the applications listed below which require a high reliability to prevent the defects which might cause a damage to the Peoples' life and/or property.

- 1) Aircraft equipment
- 2) Aerospace equipment
- 3) Undersea equipment
- 4) Power plant control equipment
- 5) Medical equipment
- 6) Transportation equipment (trains, ships, etc.)
- 7) Traffic signal equipment
- 8) Disaster prevention / crime prevention equipment
- 9) Data-processing equipment
- 10) Military equipment (regardless of directly/indirectly)
- 11) Security device/system
- 12) Outside-usage, in which the transducer is exposed to splashes or dusts
- 13) Application of similar complexity and/or reliability requirement to the applications listed in the above

### 8-2 Fail-safe

Please make sure to provide an appropriate fail-safe function on your product to prevent a second damage that may be caused by the abnormal function or the failure of our product.

## 9. Caution in use

### 9-1 (Notice in design and usage)

- 1) The transducer may generate surge voltage by mechanical or thermal shock.
- 2) Please do not apply D.C. voltage for ultrasonic transducer to avoid migration.
- 3) Please do not use this ultrasonic transducer in water.
- 4) Please do not apply an excessive mechanical shock or force on the top of this ultrasonic transducer and terminal pins. It may cause of disconnection and malfunction.
- 5) Please do not use nor storage this ultrasonic transducer in heavy dust condition. It may be a cause of clogging and low performance. Also, please do not use this transducer in high humidity or high concentrated exhaust gas. It may be a cause of corrosion and malfunction.
- 6) Care should be taken when select the material to hold, or cover backside of transducer. If it contains sulfur or sulfide, electrode on piezo-electric element may be corroded and became malfunction.
- 7) This transducer does not have a definition of terminal polarity. Please check a signal before using if you need a signal phase control for your application.

### 9-2 (Notice in storage)

- 1) The products should not be used or stored in a corrosive atmosphere, especially where chloride gas, sulfide gas, acid, alkali, salt or the like are present. Store the products in the room where is normal temperature and humidity, and avoid the sunlight, sudden changes in temperature and humidity. It may cause of failure or malfunction in such conditions.
- 2) Store the products where the temperature and relative humidity do not exceed -10 to 40 degC, and 30 to 80 %RH. Use the products within 6 months after receiving.

### 9-3 (Notice in mounting)

- 1) Please do not apply excessive force to terminals, when soldering.
- 2) Please use soldering temperature with not exceeds 350 degC, 3 seconds.
- 3) Flow soldering is not applicable.
- 4) Please do not clean by water and dissolving agent.
- 5) This product cannot be used mounted on PCB. Soldering fillet at the bottom of case may interfere with throughhole of PCB. Please contact products engineering section of Murata if you will use this product mounted on PCB.

### 10. ⚠ Note

- 1) Please make sure that your product has been evaluated in view of your specifications with our product being mounted to your product.
- 2) You are requested not to use our product deviating from the agreed specifications.
- 3) We consider inappropriate to include any terms or conditions with regard to the business transaction in the product specifications, drawings or other technical documents. Therefore, if your technical documents as above include such terms and conditions such as warranty clause, product liability clause, or intellectual property infringement liability clause, they will be deemed to be invalid.

### Dimensions

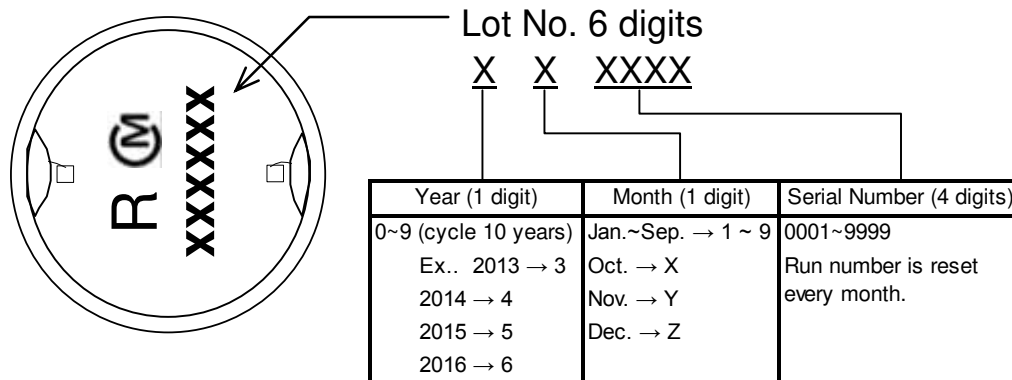
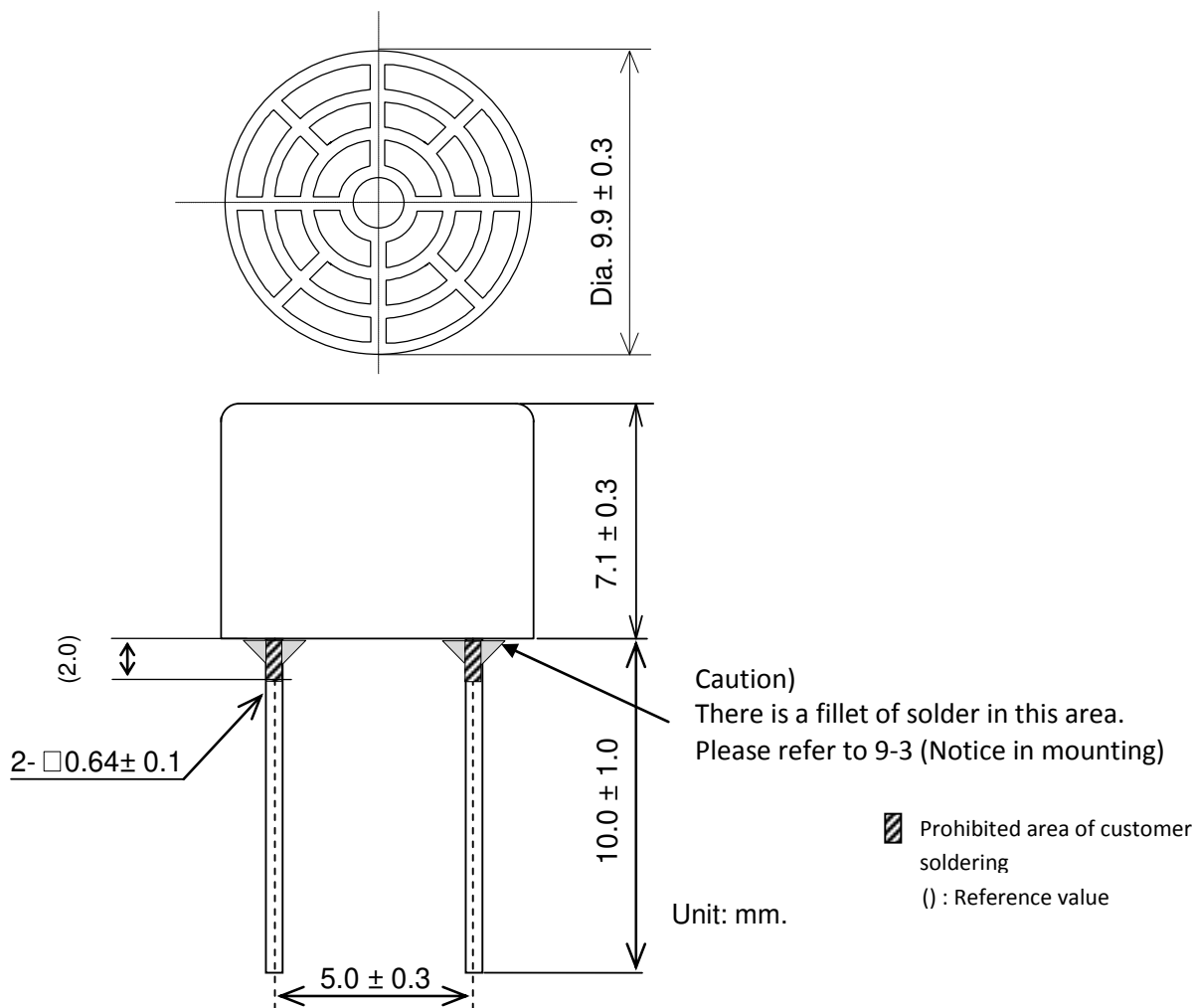

Fig.1: Product Dimension

## Measuring Circuit

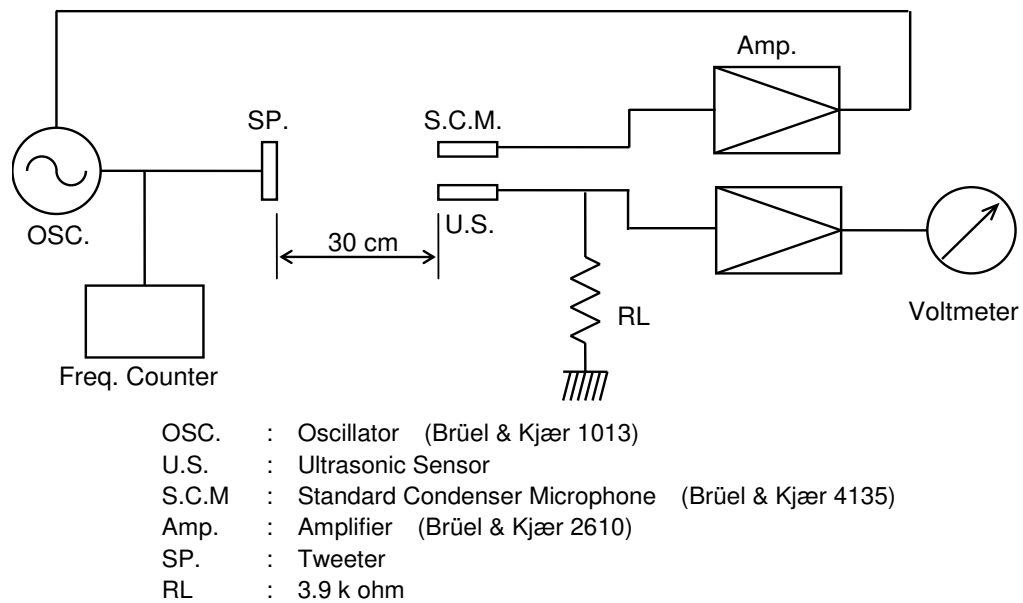

Fig. 2: Murata standard measuring

**Condition :** U.S. and S.C.M must be aligned with the line of SP., and fixed distance: 30 cm when measuring.

An input Sound Pressure Level is 94 dB at 40 kHz.

### How to measure a temperature characteristic :

After inputting a product into the thermostatic chamber in 15 min. or more,

Measure the product according to the above method immediately