



LOW POWER STEREO AUDIO CODEC WITH HEADPHONE / SPEAKER AMPLIFIER AND 12-BIT BATTERY / TEMPERATURE / AUXILIARY ADC

FEATURES

- Low Power High Quality Audio Codec
- Stereo Audio DAC and Mono Audio ADC Support Rates up to 48 ksp/s
- High Quality 97-dBA Stereo Audio Playback Performance
- Low Power: 11-mW Stereo Audio Playback at 48 ksp/s
- On-Chip 325-mW, 8-Ω Speaker Driver
- Stereo Headphone Amplifier With Capless Output Option
- Microphone Preamp and Hardware Automatic Gain Control
- Integrated PLL for Flexible Audio Clock Generation
- Programmable Digital Audio Bass/Treble/EQ/De-Emphasis
- Direct Battery Measurement Accepts up to 6-V Input
- On-Chip Temperature Measurement
- SPI™ and I²S™ Serial Interface
- Full Power-Down Control
- 32-Pin 5×5 mm QFN Package

APPLICATIONS

- Cellular and Smart Phones
- MP3 Players
- Digital Still Cameras
- Digital Video Camcorders

DESCRIPTION

The TLV320AIC26 is a high-performance audio codec with 16/20/24/32-bit 97-dBA stereo playback, mono record functionality at up to 48 ksp/s. A microphone input includes built-in preamp and hardware automatic gain control, with single-ended or fully-differential input capability.

The audio output drivers on the 'AIC26 are highly flexible, having software-programmable low or high-power drive modes to optimize system power dissipation. The outputs can be configured to supply up to 325 mW into a bridge terminated 8-Ω load, can support stereo 16-Ω headphone amplifiers in ac-coupled or capless output configurations, and can supply a stereo line-level output

A programmable digital audio effects processor enables bass, treble, midrange, or equalization playback processing. The digital audio data format is programmable to work with popular audio standard protocols (I²S, DSP, Left/Right Justified) in master or slave mode, and also includes an on-chip programmable PLL for flexible clock generation capability. Highly configurable software power control is provided, enabling stereo audio playback at 48 ksp/s at 11 mW with a 3.3-V analog supply level.

The 'AIC26 offers a 12-bit measurement ADC and internal reference voltage, as well as two battery measurement inputs capable of reading battery voltages up to 6 V, while operating at an analog supply as low as 2.7 V. It includes an on-chip temperature sensor capable of reading 0.3°C resolution. The 'AIC26 is available in a 32 lead QFN.



Please be aware that an important notice concerning availability, standard warranty, and use in critical applications of Texas Instruments semiconductor products and disclaimers thereto appears at the end of this data sheet.

SPI is a trademark of Motorola.

I²S is a trademark of Phillips Electronics.



This integrated circuit can be damaged by ESD. Texas Instruments recommends that all integrated circuits be handled with appropriate precautions. Failure to observe proper handling and installation procedures can cause damage.

ESD damage can range from subtle performance degradation to complete device failure. Precision integrated circuits may be more susceptible to damage because very small parametric changes could cause the device not to meet its published specifications.

PACKAGE/ORDERING INFORMATION

PRODUCT	PACKAGE	PACKAGE DESIGNATOR	OPERATING TEMPERATURE RANGE	ORDERING NUMBER	TRANSPORT MEDIA, QUANTITY
TLV320AIC26	QFN-32	RHB	-40°C to 85°C	TLV320AIC26IRHB	Tubes, 74
				TLV320AIC26IRHBR	Tape and Reel, 3000

PIN ASSIGNMENTS

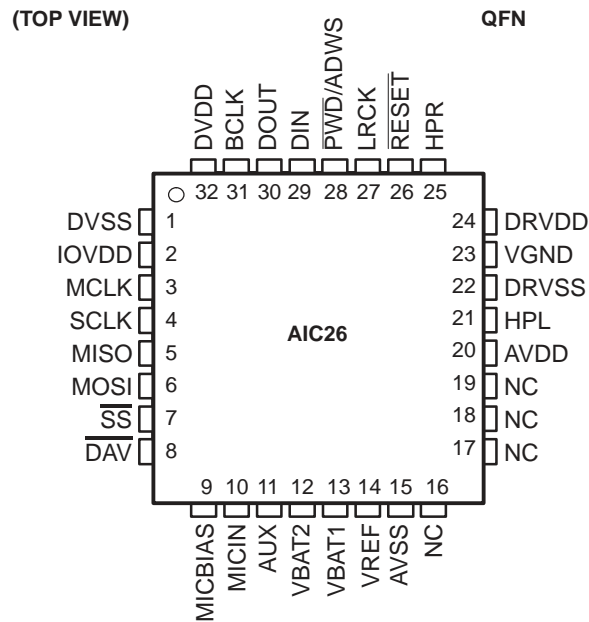

Terminal Functions

QFN PIN	NAME	DESCRIPTION	QFN PIN	NAME	DESCRIPTION
29	DIN	Audio data input	13	VBAT1	Battery monitor input
30	DOUT	Audio data output	14	VREF	Reference voltage I/O
31	BCLK	Audio bit-clock	15	AVSS	Analog ground
32	DVDD	Digital core supply	16	NC	No connect
1	DVSS	Digital core and IO ground	17	NC	No connect
2	IOVDD	IO supply	18	NC	No connect
3	MCLK	Master clock	19	NC	No connect
4	SCLK	SPI serial clock input	20	AVDD	Analog power supply
5	MISO	SPI serial data output	21	HPL	Left channel audio output
6	MOSI	SPI serial data input	22	DRVSS	Speaker ground
7	SS	SPI slave select input	23	VGND	Virtual ground for audio output
8	DAV	Auxiliary data available output	24	DRVDD	Speaker /PLL supply
9	MICBIAS	Microphone bias voltage	25	HPR	Right channel audio output
10	MICIN	Microphone input	26	RESET	Device reset
11	AUX	Auxiliary input	27	LRCK	Audio DAC word-clock
12	VBAT2	Battery monitor input	28	PWD/ADWS	Hardware powerdown/ADC word clock

ABSOLUTE MAXIMUM RATINGS

over operating free-air temperature range unless otherwise noted⁽¹⁾⁽²⁾

		UNITS
AVDD to AVSS		–0.3 V to 3.9 V
DRVDD to DRVSS		–0.3 V to 3.9 V
IOVDD to DVSS		–0.3 V to 3.9 V
DVDD to DVSS		–0.3 V to 2.5 V
AVDD to DRVDD		–0.1 V to 0.1 V
AVSS to DRVSS to DVSS		–0.1 V to 0.1 V
Analog inputs (except VBAT1 and VBAT2) to AVSS		–0.3 V to AVDD + 0.3 V
VBAT1 / VBAT2 to AVSS		–0.3 V to 6 V
Digital input voltage to DVSS		–0.3 V to IOVDD + 0.3 V
Operating temperature range		–40°C to 85°C
Storage temperature range		–65°C to 105°C
Junction temperature (T _J Max)		105°C
QFN package	Power dissipation	(T _J Max – T _A)/θ _{JA}
	θ _{JA} Thermal impedance	123°C/W
Lead temperature	Soldering vapor phase (60 sec)	215°C
	Infrared (15 sec)	220°C

(1) Stresses beyond those listed under “absolute maximum ratings” may cause permanent damage to the device. These are stress ratings only, and functional operation of the device at these or any other conditions beyond those indicated under “recommended operating conditions” is not implied. Exposure to absolute-maximum-rated conditions for extended periods may affect device reliability.

(2) If the 'AIC26 is used to drive high power levels to an 8-Ω load for extended intervals at ambient temperatures above 70°C, multiple vias should be used to electrically and thermally connect the thermal pad on the QFN package to an internal heat-dissipating ground plane on the user's PCB.

ELECTRICAL CHARACTERISTICS

At +25°C, AVDD,DRVDD,IOVDD = 3.3 V, DVDD = 1.8 V, Int. V_{ref} = 2.5 V, Fs (Audio) = 48 kHz, unless otherwise noted

PARAMETER	TEST CONDITIONS	MIN	TYP	MAX	UNITS
BATTERY MONITOR INPUTS					
Input voltage range		0.5		6.0	V
Input leakage current	Battery conversion not selected		±1		µA
AUXILIARY A/D CONVERTER					
Resolution	Programmable: 8-, 10-,12-bits			12	Bits
No missing codes	12-bit resolution		11		Bits
Integral nonlinearity		-5		5	LSB
Offset error		-6		6	LSB
Gain error	Calculated with effect of internal reference variation removed.	-6		6	LSB
Noise			53		µVrms
AUDIO CODEC					
ADC DECIMATION FILTER					
	Sample rate of 48 ksps				
Filter gain from 0 to 0.39Fs			±0.1		dB
Filter gain at 0.4125Fs			-0.25		dB
Filter gain at 0.45Fs			-3		dB
Filter gain at 0.5Fs			-17.5		dB
Filter gain from 0.55Fs to 64Fs			-75		dB
Filter group delay			17/Fs		sec
MICROPHONE INPUT TO ADC					
	1 kHz sine wave input, Fs = 48 ksps				
Full scale input voltage (0 dB)	By design, not tested in production		0.707		Vrms
Input common mode	By design, not tested in production		1.35		V
SNR	Measured as idle channel noise, 0-dB gain, A-weighted	80	92		dBA
THD	0.63-Vrms input, 0-dB gain		-89	-72	dB
PSRR	1 kHz, 100 mVpp on AVDD.(1)		57		dB
Mute attenuation	Output code with 0.63-Vrms sine wave input at 1 kHz		0000H		
Input resistance			20		kΩ
Input capacitance			10		pF
MICROPHONE BIAS					
Voltage	D4 = 0 control register 05H/Page2		2.5		V
	D4 = 1 control register 05H/Page2		2.0		V
Sourcing current			4.7		mA

(1) ADC PSRR measurement is calculated as:

$$PSRR = 20 \log_{10} \left(\frac{V_{SIG_{sup}}}{V_{ADCOUT}} \right)$$

ELECTRICAL CHARACTERISTICS

At +25°C, AVDD,DRVDD,IOVDD = 3.3 V, DVDD = 1.8 V, Int. V_{ref} = 2.5 V, Fs (Audio) = 48 kHz, unless otherwise noted (continued)

PARAMETER	TEST CONDITIONS	MIN	TYP	MAX	UNITS
DAC INTERPOLATION FILTER					
Pass band		20		0.45 Fs	Hz
Pass band ripple			±0.06		dB
Transition band		0.45 Fs		0.5501 Fs	Hz
Stop band		0.5501 Fs		7.455 Fs	Hz
Stop band attenuation			65		dB
Filter group delay			21/Fs		sec
De-emphasis error			±0.1		dB
DAC LINE OUTPUT					
	1-kHz sine wave input, 48 ksps, output drivers in low power mode, load = 10 kΩ, 10 pF				
Full scale output voltage (0 dB)	By design, D10–D9 = 00 in control register 06H/Page2 corresponding to 2-V _{pp} output swing		0.707		V _{rms}
Output common mode	By design, D10–D9 = 00 in control register 06H/Page2 corresponding to 2-V _{pp} output swing		1.35		V
SNR	Measured as idle channel noise, A-weighted	85	97		dBA
THD	0-dB FS input, 0-dB gain		–95		dB
PSRR	1 kHz, 100 mV _{pp} on AVDD ⁽²⁾ VGND powered down		56		dB
Interchannel isolation	Coupling from ADC to DAC		84		dB
DAC HEADPHONE OUTPUT					
	1-kHz sine wave input, 48 ksps, output drivers in high power mode, load = 16 Ω, 10 pF				
Full scale output voltage (0 dB)	By design, D10–D9 = 00 in control register 06H/Page2 corresponding to 2-V _{pp} output swing		0.707		V _{rms}
SNR	Measured as idle channel noise, A-weighted	85	97		dBA
THD	–1 dB FS input, 0-dB gain		–91	–55	dB
PSRR	1 kHz, 100 mV _{pp} on AVDD ⁽¹⁾ VGND powered down		54		dB
Interchannel isolation	Coupling from ADC to DAC		85		dB
Mute attenuation			121		dB
Maximum output power	D10–D9 = 00 in control register 06H/Page2		30		mW
Digital volume control gain		–63.5		0	dB
Digital volume control step size			0.5		dB
Channel separation	Between HPL and HPR		80		dB
DAC SPEAKER OUTPUT					
	Output driver in high power mode, load = 8 Ω, connected between HPR and HPL pins. D10–D9 = 10 in control register 06H/Page2 corresponding to 2.402-V _{pp} output swing				
Output power	0 dB input to DAC		325		mW
SNR	Measured as idle channel noise, A-weighted		102		dBA
THD	–1 dB FS input, 0-dB gain		–86		dB
	–6 dB FS input, 0-dB gain		–88		dB

(1) DAC PSRR measurement is calculated as:

$$PSRR = 20 \log_{10} \left(\frac{V_{SIG_{sup}}}{V_{HPR/L}} \right)$$

ELECTRICAL CHARACTERISTICS

At +25°C, AVDD,DRVDD,IOVDD = 3.3 V, DVDD = 1.8 V, Int. V_{ref} = 2.5 V, Fs (Audio) = 48 kHz, unless otherwise noted (continued)

PARAMETER	TEST CONDITIONS	MIN	TYP	MAX	UNITS
VOLTAGE REFERENCE					
Voltage range	VREF output programmed as 2.5 V	2.3	2.5	2.7	V
	VREF output programmed as 1.25 V	1.15	1.25	1.35	
Voltage range	External VREF. By design, not tested in production.	1.2		2.55	V
Reference drift	Internal VREF = 1.25 V		29		ppm/°C
Current drain	Extra current drawn when the internal reference is turned on.		650		μA
DIGITAL INPUT / OUTPUT(1)					
Internal clock frequency			8.8		MHz
Logic family			CMOS		
Logic level: V _{IH}	I _{IH} = +5 μA	0.7xIOVDD			V
V _{IL}	I _{IL} = +5 μA	-0.3		0.3xIOVDD	V
V _{OH}	I _{OH} = 2 TTL loads	0.8xIOVDD			V
V _{OL}	I _{OL} = 2 TTL loads			0.1xIOVDD	V
Capacitive load			10		pF
POWER SUPPLY REQUIREMENTS					
Power supply voltage					
AVDD(2)		2.7		3.6	V
DRVDD(2)		2.7		3.6	v
IOVDD		1.1		3.6	V
DVDD		1.525		1.95	V
Stereo audio playback	IAVDD	48 ksps, output drivers in low power mode, VGND off, PLL off	2.2		mA
	IDRVDD		0		
	IDVDD		2.4		
Microphone record	IAVDD	48 ksps, no playback, PLL off	2.9		mA
	IDRVDD		0		
	IDVDD		1.4		
PLL	IAVDD	Additional power consumed when PLL is enabled.	0.1		mA
	IDRVDD		1.3		
	IDVDD		0.9		
VGND	IAVDD	Additional power consumed when VGND is powered.	0.3		mA
	IDRVDD		0.9		
	IDVDD		0		
Hardware power down	All currents		2		μA

(1) Internal oscillator is designed to give nominally 8-MHz clock frequency. However, due to process variations, this frequency can vary from device to device. All calculations for delays and wait times in the data sheet assume an 8-MHz oscillator clock.

(2) It is recommended that AVDD and DRVDD be set to the same voltage for the best performance. It is also recommended that these supplies be separated on the user's PCB.

FUNCTIONAL BLOCK DIAGRAM

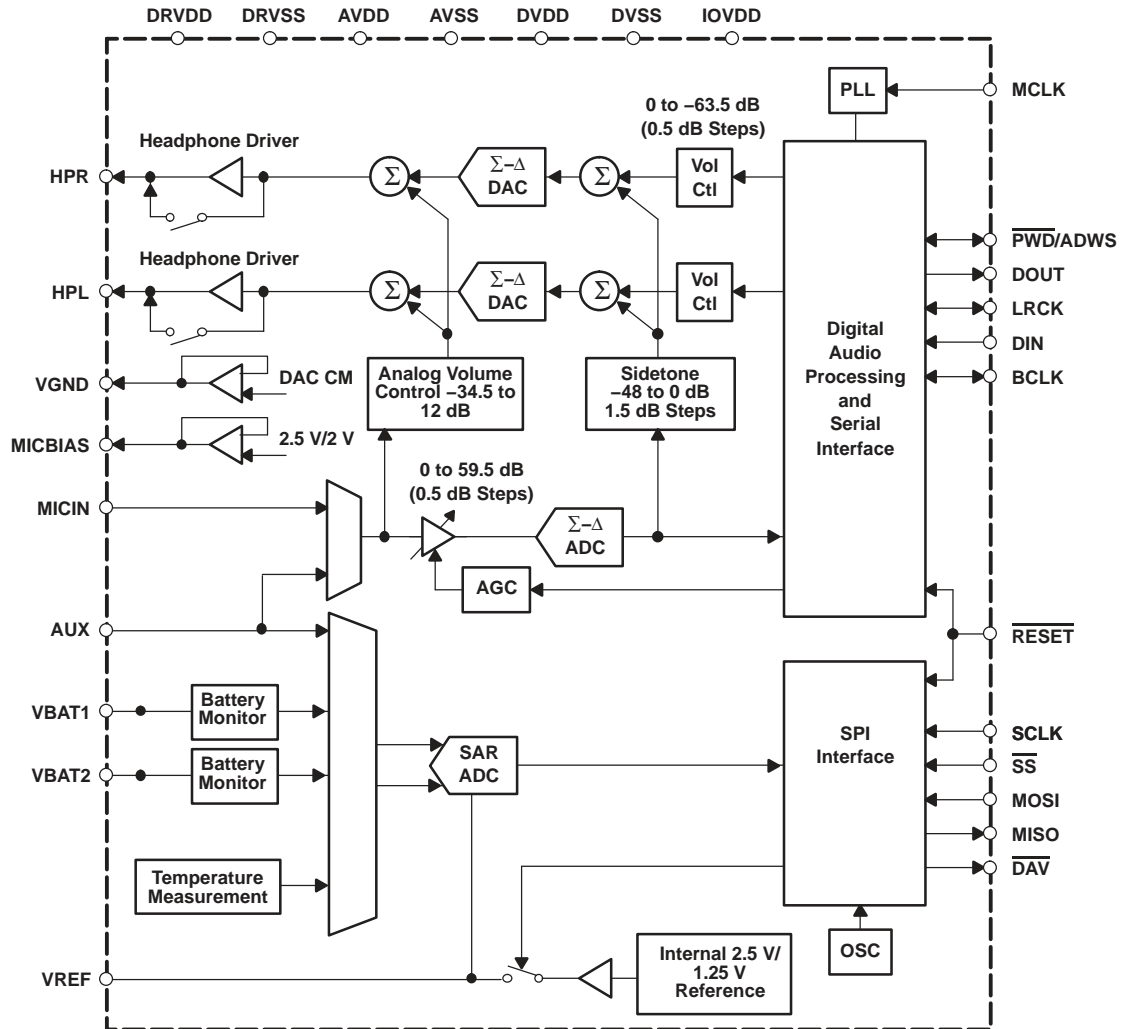

SPI TIMING DIAGRAM

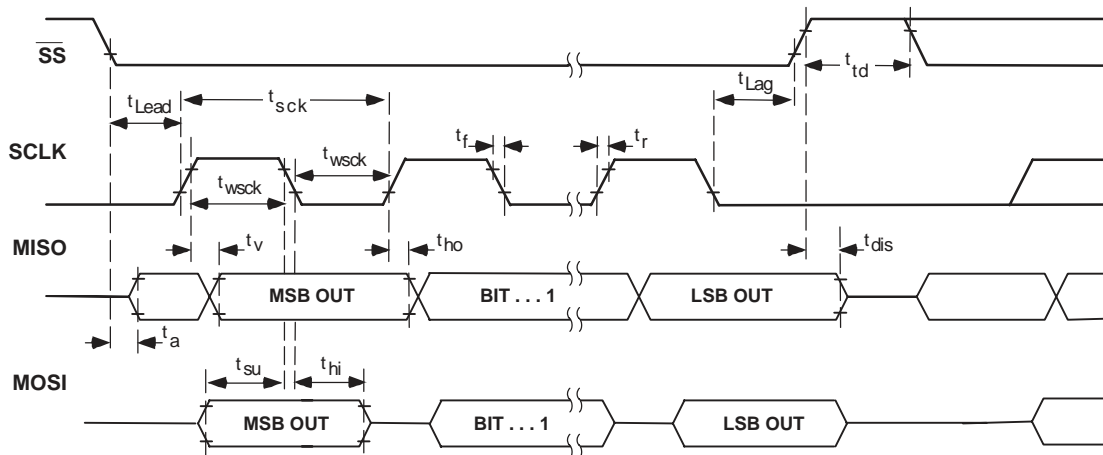

TYPICAL TIMING REQUIREMENTS

All specifications at 25°C, DVDD = 1.8 V (1)

PARAMETER	IOVDD = 1.1 V		IOVDD = 3.3 V		UNITS
	MIN	MAX	MIN	MAX	
t_{wsck} SCLK pulse width	27		18		ns
t_{Lead} Enable lead time	18		15		ns
t_{Lag} Enable lag time	18		15		ns
t_d Sequential transfer delay	18		15		ns
t_a Slave MISO access time		18		15	ns
t_{dis} Slave MISO disable time		18		15	ns
t_{su} MOSI data setup time	6		6		ns
t_{hi} MOSI data hold time	6		6		ns
t_{ho} MISO data hold time	4		4		ns
t_v MISO data valid time		22		13	ns
t_r Rise time		6		4	ns
t_f Fall time		6		4	ns

(1) These parameters are based on characterization and are not tested in production.

AUDIO INTERFACE TIMING DIAGRAMS

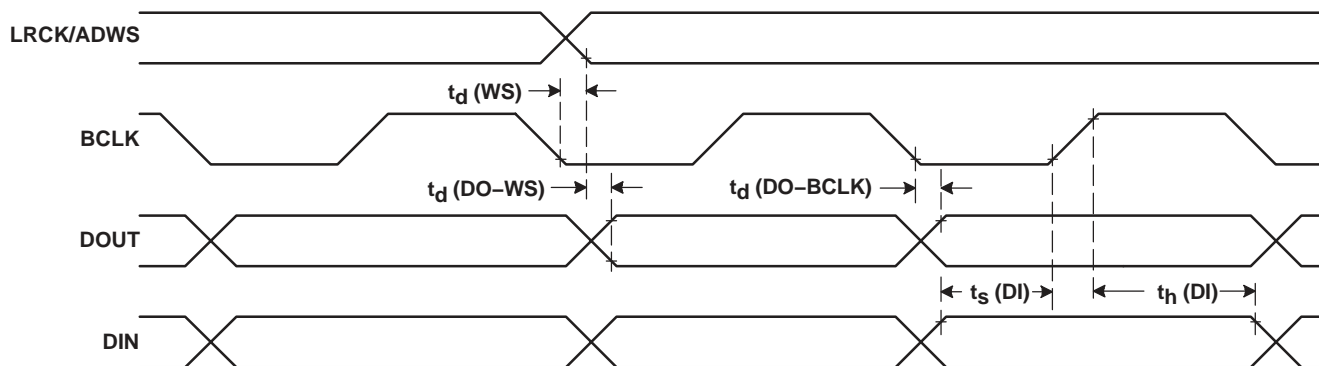

Figure 1. I²S/LJF/RJF Timing in Master Mode

TYPICAL TIMING REQUIREMENTS (FIGURE 1)

All specifications at 25°C, DVDD = 1.8 V ⁽¹⁾

PARAMETER	IOVDD = 1.1 V		IOVDD = 3.3 V		UNITS
	MIN	MAX	MIN	MAX	
t_d (WS) ADWS/LRCK delay		25		15	ns
t_d (DO-WS) ADWS to DOUT delay (for LJF mode)		25		15	ns
t_d (DO-BCLK) BCLK to DOUT delay		25		15	ns
t_s (DI) DIN setup	6		6		ns
t_h (DI) DIN hold	6		6		ns
t_r Rise time		10		6	ns
t_f Fall time		10		6	ns

(1) These parameters are based on characterization and are not tested in production.

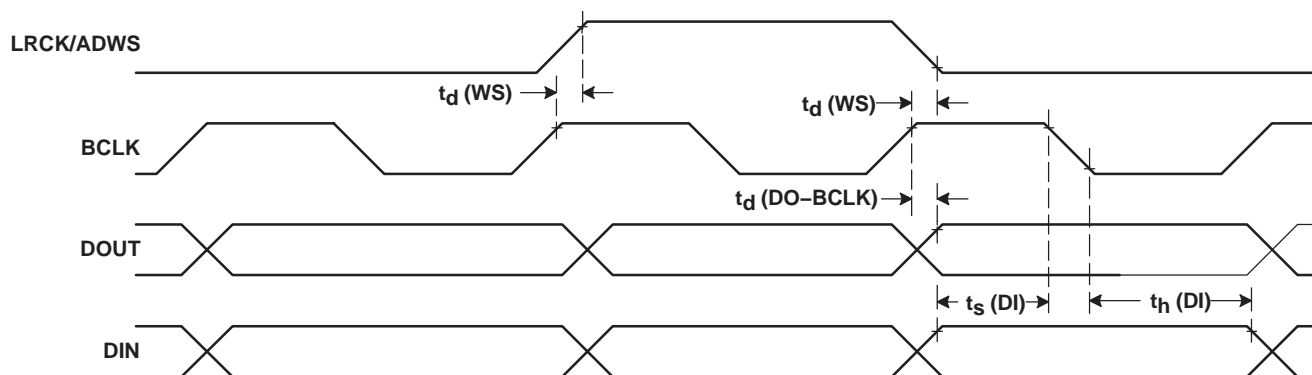

Figure 2. DSP Timing in Master Mode

TYPICAL TIMING REQUIREMENTS (FIGURE 2)

All specifications at 25°C, DVDD = 1.8 V ⁽¹⁾

PARAMETER	IOVDD = 1.1 V		IOVDD = 3.3 V		UNITS
	MIN	MAX	MIN	MAX	
t_d (WS) ADWS/LRCK delay		25		15	ns
t_d (DO-BCLK) BCLK to DOUT delay		25		15	ns
t_s (DI) DIN setup	6		6		ns
t_h (DI) DIN hold	6		6		ns
t_r Rise time		10		6	ns
t_f Fall time		10		6	ns

(1) These parameters are based on characterization and are not tested in production.

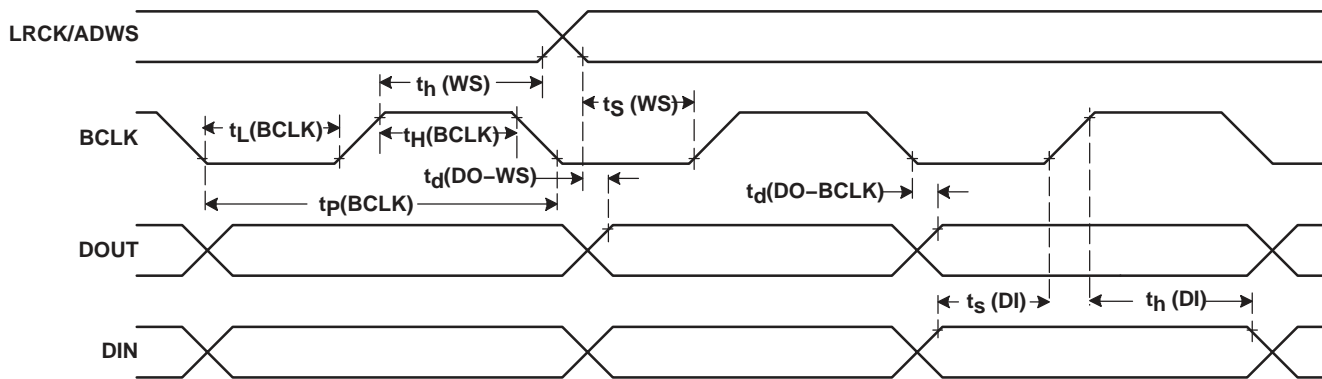

Figure 3. I²S/LJF/RJF Timing in Slave Mode

TYPICAL TIMING REQUIREMENTS (FIGURE 3)

All specifications at 25°C, DVDD = 1.8 V (1)

PARAMETER		IOVDD = 1.1 V		IOVDD = 3.3 V		UNITS
		MIN	MAX	MIN	MAX	
t _H (BCLK)	BCLK high period	35		35		ns
t _L (BCLK)	BCLK low period	35		35		ns
t _S (WS)	ADWS/LRCK setup	6		6		ns
t _H (WS)	ADWS/LRCK hold	6		6		ns
t _d (DO–WS)	ADWS to DOUT delay (for LJF mode)		25		18	ns
t _d (DO–BCLK)	BCLK to DOUT delay		25		15	ns
t _S (DI)	DIN setup	6		6		ns
t _H (DI)	DIN hold	6		6		ns
t _r	Rise time		5		4	ns
t _f	Fall time		5		4	ns

(1) These parameters are based on characterization and are not tested in production.

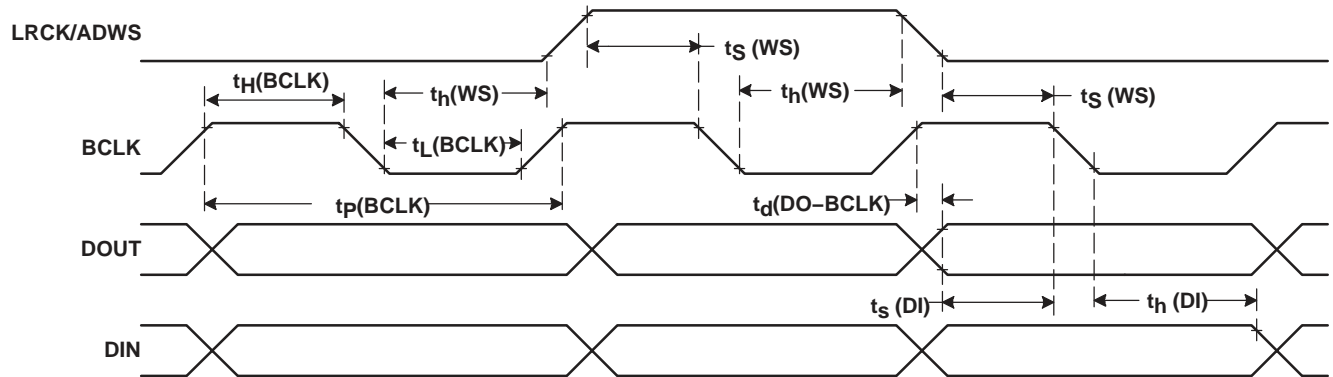

Figure 4. DSP Timing in Slave Mode

TYPICAL TIMING REQUIREMENTS (FIGURE 4)

All specifications at 25°C, DVDD = 1.8 V ⁽¹⁾

PARAMETER		IOVDD = 1.1 V		IOVDD = 3.3 V		UNITS
		MIN	MAX	MIN	MAX	
$t_H(\text{BCLK})$	BCLK high period	35		35		ns
$t_L(\text{BCLK})$	BCLK low period	35		35		ns
$t_s(\text{WS})$	ADWS/LRCK setup	6		6		ns
$t_h(\text{WS})$	ADWS/LRCK hold	6		6		ns
$t_d(\text{DO-BCLK})$	BCLK to DOUT delay		25		15	ns
$t_s(\text{DI})$	DIN setup	6		6		ns
$t_h(\text{DI})$	DIN hold	6		6		ns
t_r	Rise time		5		4	ns
t_f	Fall time		5		4	ns

⁽¹⁾ These parameters are based on characterization and are not tested in production.

TYPICAL CHARACTERISTICS

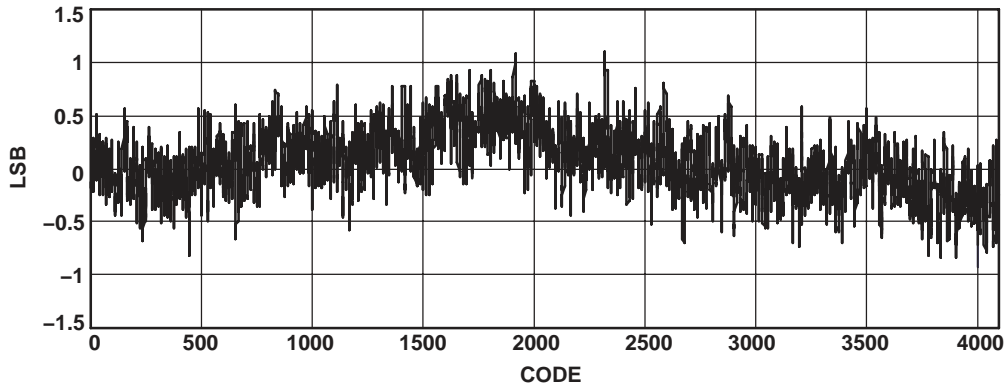

Figure 5. SAR INL ($T_A = 25^\circ\text{C}$, Internal Ref = 2.5 V, 12 bit, AVDD = 3.3 V)

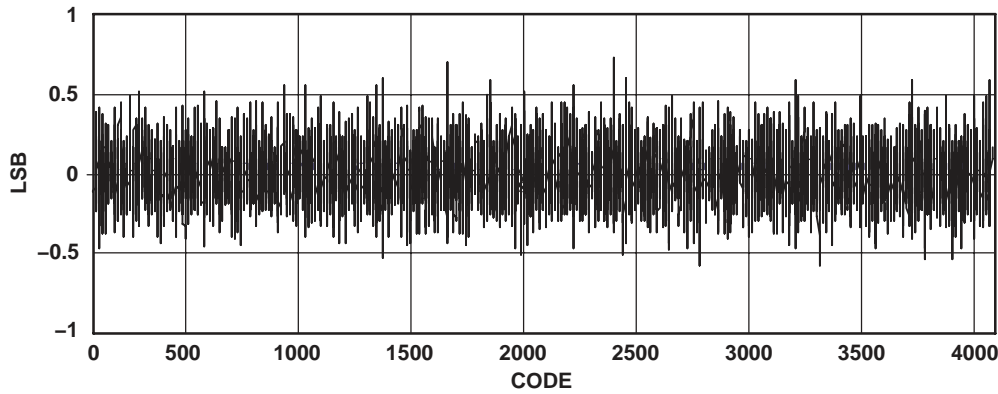

Figure 6. SAR DNL ($T_A = 25^\circ\text{C}$, Internal Ref = 2.5 V, AVDD = 3.3 V)

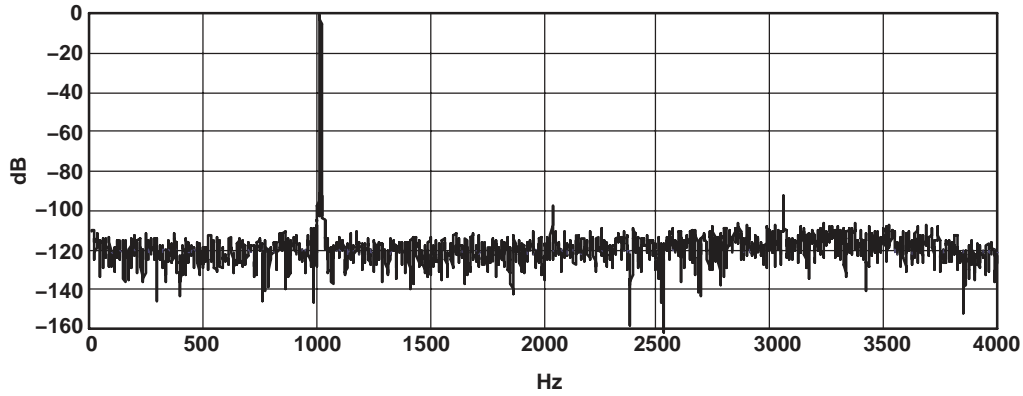

Figure 7. ADC FFT Plot at 8 ksps ($T_A = 25^\circ\text{C}$, -1 dB, 1 kHz Input, AVDD = 3.3 V)

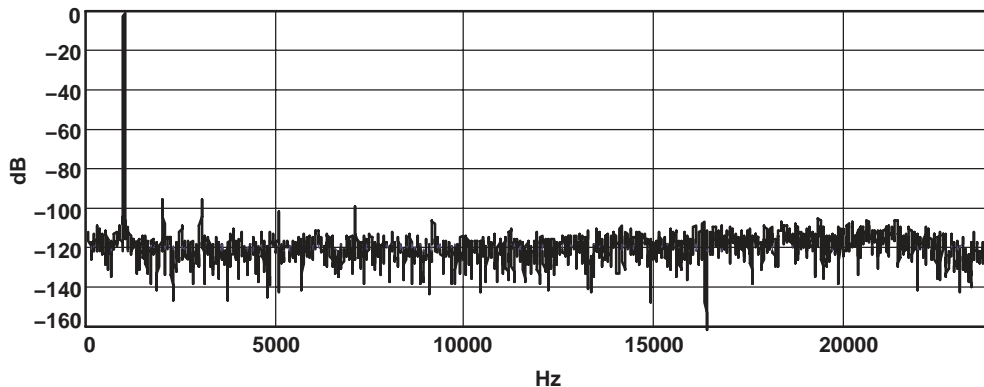

Figure 8. ADC FFT Plot at 48 ksps ($T_A = 25^\circ\text{C}$, -1 dB , 1 kHz Input, $AVDD = 3.3\text{ V}$)

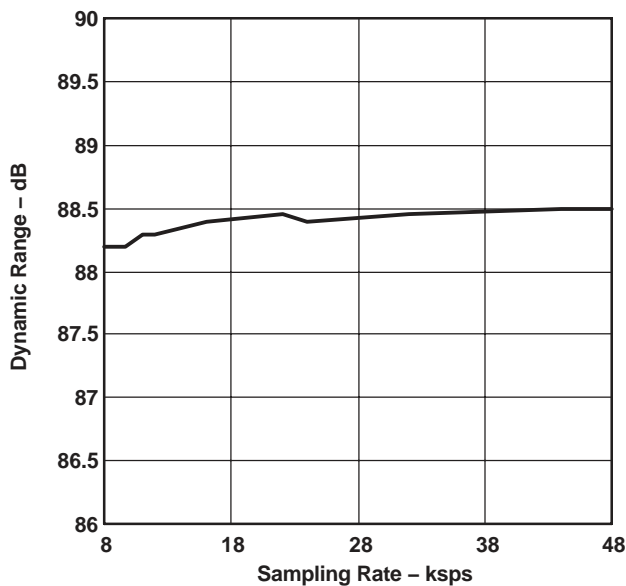

Figure 9. ADC Dynamic Range vs Sampling Speed ($T_A = 25^\circ\text{C}$, $AVDD = 3.3\text{ V}$)

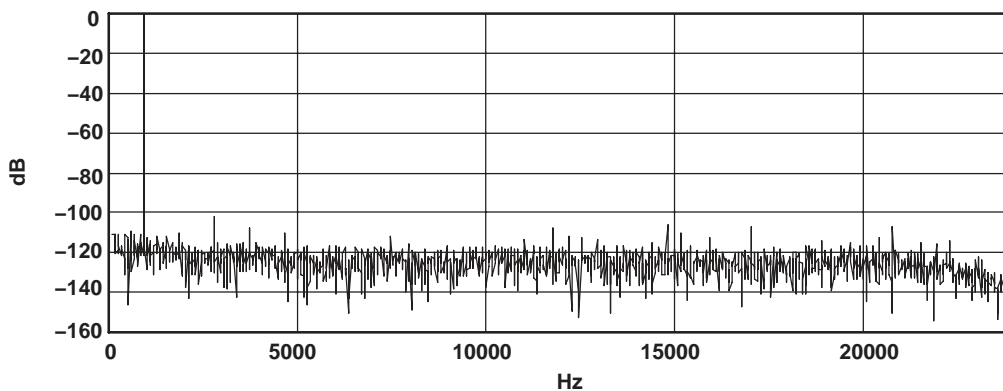

Figure 10. DAC FFT Plot ($T_A = 25^\circ\text{C}$, 48 ksps , 0 dB , 1 kHz Input, $AVDD = 3.3\text{ V}$, $R_L = 10\text{ k}\Omega$)

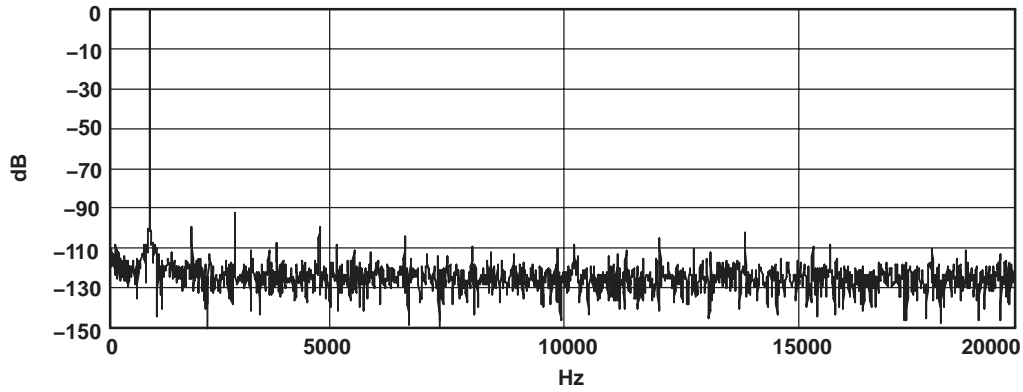

Figure 11. DAC FFT Plot ($T_A = 25^\circ\text{C}$, 48 kps, -1 dB, 1 kHz Input, $AVDD = DRVDD = 3.3\text{ V}$, $DVDD = 1.8\text{ V}$, $R_L = 16\ \Omega$)

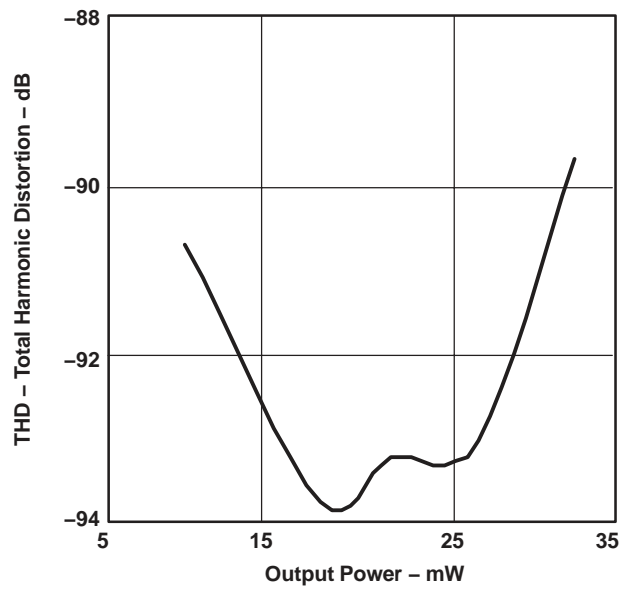

Figure 12. High Power Output Driver THD vs Output Power ($T_A = 25^\circ\text{C}$, $AVDD, DRVDD = 3.3\text{ V}$, $R_L = 16\ \Omega$)

OVERVIEW

The 'AIC26 is a highly integrated stereo audio codec for portable computing, communication, and entertainment applications. The 'AIC26 has a register-based architecture where all functions are controlled through the registers and onboard state machines.

The 'AIC26 consists of the following blocks (refer to the block diagram):

- Audio Codec
- Battery Monitors
- Auxiliary Inputs
- Temperature Monitor

Audio data is transferred between the host DSP/ μ P via a standard 4-wire interface and supports a variety of modes (i.e., I²S, DSP, etc).

Control of the 'AIC26 and its functions is accomplished by writing to different registers in the 'AIC26. A simple command protocol is used to address the 16-bit registers. Registers control the operation of the A/D converter and audio codec. The control and auxiliary functions are accessed via a SPI bus.

A typical application of the 'AIC26 is shown in Figure 13.

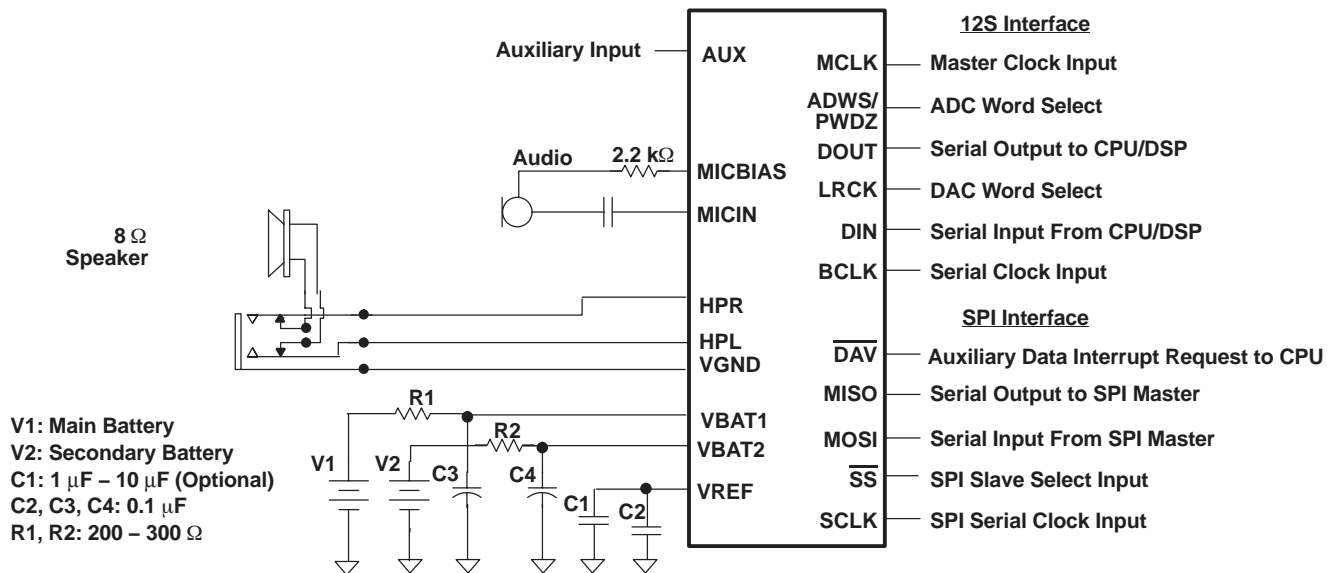

Figure 13. Typical Circuit Configuration

OPERATION–AUDIO CODEC

Audio Analog I/O

The 'AIC26 has one mono audio input (MICIN) typically used for microphone recording, and an auxiliary input (AUX) that can be used as a second microphone or line input. The dual audio output drivers have programmable power level and can be configured to drive up to 325 mW into an 8- Ω speaker, or to drive 16- Ω stereo headphones at over 30-mW per channel, or to provide a stereo line-level output. The power level of the output drivers is controlled using bit D12 in control register REG–05H/Page2. The 'AIC26 also has a virtual ground (VGND) output driver, which can optionally be used to connect the return terminal of headphones, to eliminate the ac-coupling capacitors needed at the headphone output. The VGND amplifier is controlled by bit D8 of REG–05H/Page2. A special circuit has also been included in the 'AIC26 to insert a short keyclick sound into the stereo audio output, even when the audio DAC is powered down. The keyclick sound is used to provide feedback to the user when a particular button is pressed or item is selected. The specific sound of the keyclick can be adjusted by varying several register bits that control its frequency, duration, and amplitude.

Audio Digital Interface

Digital audio data samples are transmitted between the 'AIC26 and the audio processor via the serial bus (BCLK, ADWS, DOUT, LRCK, DIN) that can be configured to transfer digital data in four different formats: right justified, left justified, I²S, and DSP. The four modes are MSB-first and operate with variable word length of 16, 20, 24, or 32 bits. The digital audio serial bus of the 'AIC26 can operate in master or slave mode, depending on its register settings. The word-select signals (ADWS, LRCK) and bit clock signal (BCLK) are configured as outputs when the bus is in master mode. They are configured as inputs when the bus is in slave mode. The ADWS is representative of the sampling rate of the audio ADC and is synchronized with DOUT. The LRCK is representative of the audio DAC sampling rate and is synchronized with DIN. Although the DOUT signal can contain two channels of information (a left and right channel), the 'AIC26 sends the same ADC data in both channels.

● ADC/DAC SAMPLING RATE

The Audio Control 1 register (Register 00H, Page2) determines the sampling rates of the audio DAC and ADC, which are scaled down from a reference rate (Fsref). The ADC and DAC can operate with either a common LRCK (equal sampling rates) or separate ADWS and LRCK (unequal sampling rates). When the audio codec is powered up, it is configured by default as an I²S slave with both the DAC and ADC operating at Fsref.

● WORD SELECT SIGNALS

The word select signal (LRCK, ADWS) indicates the channel being transmitted:

- LRCK/ADWS = 0: left channel for I²S mode
- LRCK/ADWS = 1: right channel for I²S mode

For other modes see the timing diagrams below.

Bitclock (BCLK) Signal

In addition to flexibility as master or slave mode, the BCLK can also be configured in two transfer modes—256–S and Continuous Transfer Modes. These modes are set using bit D12/REG–06h/Page2.

● 256–S TRANSFER MODE

In the 256–S mode, the BCLK rate always equals 256 times the maximum of the LRCK and ADWS frequencies. In the 256–S mode, the combination of ADC/DAC sampling rate equal to Fsref (as selected by bit D5–D0/REG–00h/Page2) and left–justified mode is not supported.

● CONTINUOUS TRANSFER MODE

In the continuous transfer mode, the BCLK rate always equals two times the word length of the maximum of the LRCK and ADWS frequencies.

● **RIGHT-JUSTIFIED MODE**

In right-justified mode, the LSB of the left channel is valid on the rising edge of the BCLK preceding the falling edge of ADWS or LRCK. Similarly, the LSB of the right channel is valid on the rising edge of the BCLK preceding the rising edge of ADWS or LRCK.

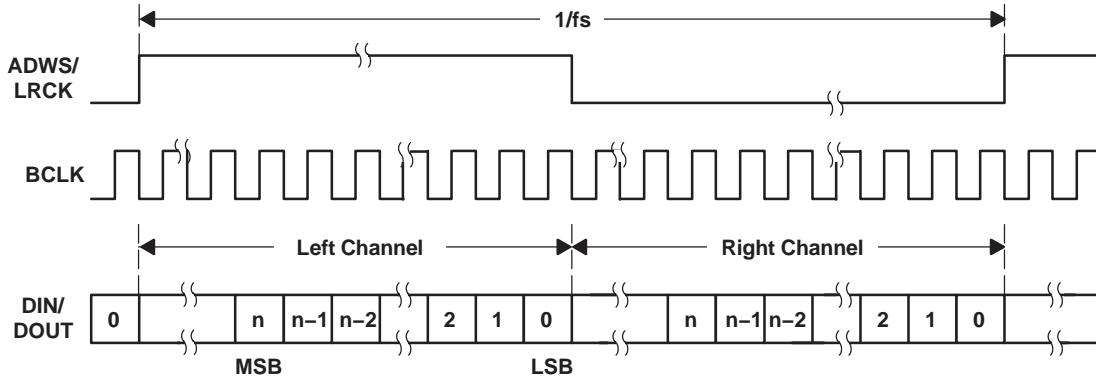

Figure 14. Timing Diagram for Right-Justified Mode

● **LEFT-JUSTIFIED MODE**

In left-justified mode, the MSB of the right channel is valid on the rising edge of the BCLK, following the falling edge of ADWS or LRCK. Similarly the MSB of the left channel is valid on the rising edge of the BCLK following the rising edge of ADWS or LRCK.

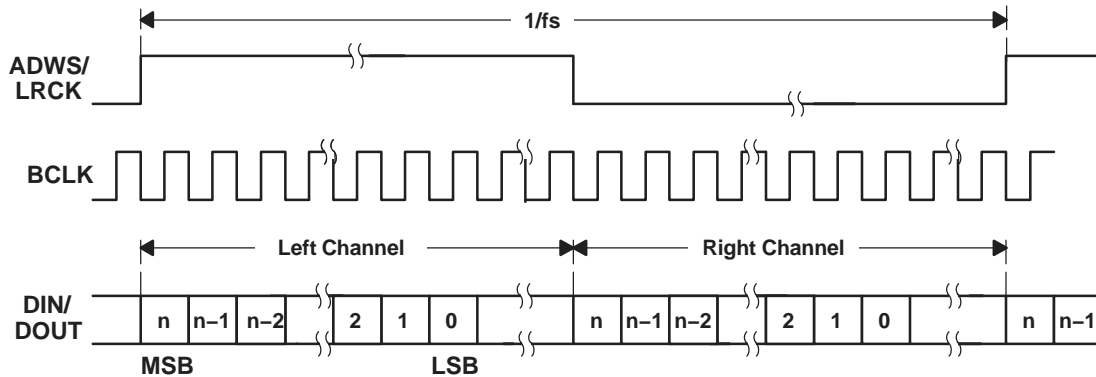

Figure 15. Timing Diagram for Left-Justified Mode

● I²S MODE

In I²S mode, the MSB of the left channel is valid on the second rising edge of the BCLK after the falling edge of ADWS or LRCK. Similarly the MSB of the right channel is valid on the second rising edge of the BCLK after the rising edge of ADWS or LRCK.

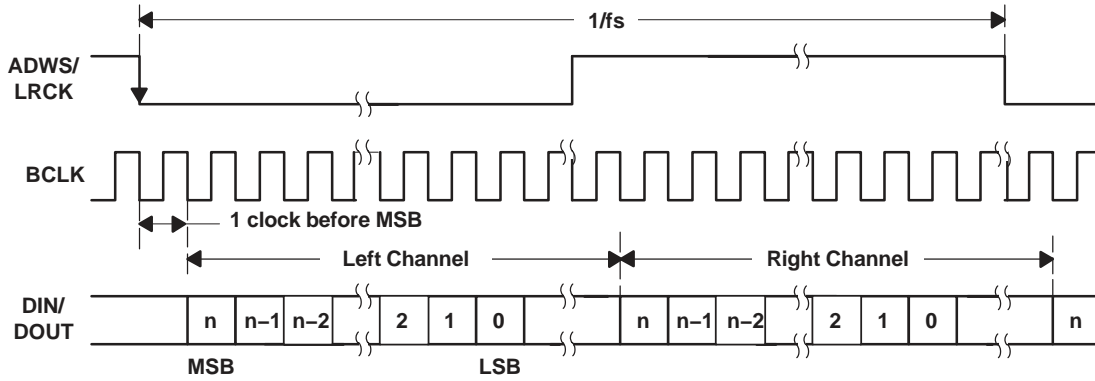

Figure 16. Timing Diagram for I²S Mode

● DSP MODE

In DSP mode, the falling edge of ADWS or LRCK starts the data transfer with the left channel data first and immediately followed by the right channel data. Each data bit is valid on the falling edge of BCLK.

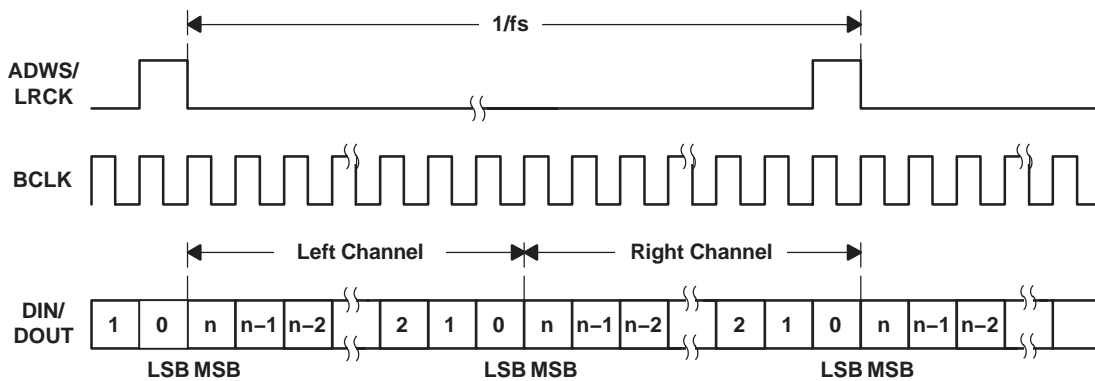

Figure 17. Timing Diagram for DSP Mode

AUDIO DATA CONVERTERS

The 'AIC26 has a stereo audio DAC and a mono audio ADC. Both ADC and DAC can operate with a maximum sampling rate of 53 kHz and support all audio standard rates of 8 kHz, 11.025 kHz, 12 kHz, 16 kHz, 22.05 kHz, 24 kHz, 32 kHz, 44.1 kHz, and 48 kHz. By utilizing the flexible clock generation capability and internal programmable interpolation, a wide variety of sampling rates up to 53 kHz can be obtained from many possible MCLK inputs. In addition, the DAC and ADC can independently operate at different sampling rates as indicated in control register REG–00H/Page2.

When the ADC or DAC is operating, the 'AIC26 requires an applied audio MCLK input. The user should also set bit D13/REG–06H/Page2 to indicate which Fsref rate is being used. If the codec ADC or DAC is powered up, then the auxiliary ADC uses MCLK and BCLK for its internal clocking, and the internal oscillator is powered down to save power.

Typical audio DACs can suffer from poor out-of-band noise performance when operated at low sampling rates, such as 8 kHz or 11.025 kHz. The 'AIC26 includes programmable interpolation circuitry to provide improved audio performance at such low sampling rates, by first upsampling low-rate data to a higher rate, filtering to reduce audible images, and then passing the data to the internal DAC, which is actually operating at the Fsref rate. This programmable interpolation is determined using bit D5–D3/REG–00H/Page2.

For example, if playback of 11.025-kHz data is required, the 'AIC26 can be configured such that Fsref = 44.1 kHz. Then using bit D5–D3/REG–00H/Page2, the DAC sampling rate (Fs) can be set to Fsref/4, or Fs = 11.025 kHz. In operation, the 11.025-kHz digital input data is received by the 'AIC26, upsampled to 44.1 kHz, and filtered for images. It is then provided to the audio DAC operating at 44.1 kHz for playback. In reality, the audio DAC further upsamples the 44.1 kHz data by a ratio of 128x and performs extensive interpolation filtering and processing on this data before conversion to a stereo analog output signal.

PLL

The 'AIC26 has an on-chip PLL to generate the needed internal ADC and DAC operational clocks from a wide variety of clocks available in the system. The PLL supports an MCLK varying from 2 MHz to 50 MHz and is register programmable to enable generation of required sampling rates with fine precision.

ADC and DAC sampling rates are given by

$$\text{DAC_FS} = \text{Fsref}/N1 \text{ and } \text{ADC_FS} = \text{Fsref}/N2$$

where, Fsref must fall between 39 kHz and 53 kHz, and N1, N2 = 1, 1.5, 2, 3, 4, 5, 5.5, 6 are register programmable.

The PLL can be enabled or disabled using register programming.

- When PLL is disabled

$$\text{Fsref} = \frac{\text{MCLK}}{128 \times Q}$$

Q = 2, 3...17

- Note: For ADC, with N2 = 1.5 or 5.5, odd values of Q are not allowed.
- In this mode, the MCLK can operate up to 50 MHz, and Fsref should fall within 39 kHz to 53 kHz.

- When PLL is enabled

$$\text{Fsref} = \frac{\text{MCLK} \times K}{2048 \times P}$$

P = 1, 2, 3, ..., 8

K = J.D

J = 1, 2, 3, ..., 64

D = 0, 1, 2, ..., 9999

P, J, and D are register programmable, where J is an integer part of K before the decimal point, and D is a four-digit fractional part of K after the decimal point, including lagging zeros.

Examples: If K = 8.5, Then J = 8, D = 5000
 If K = 7.12, Then J = 7, D = 1200
 If K = 7.012, Then J = 7, D = 120

The PLL is programmed through Registers 1BH and 1CH of Page2.

- When PLL is enabled and $D = 0$, the following condition must be satisfied

$$2 \text{ MHz} \leq \frac{\text{MCLK}}{P} \leq 20 \text{ MHz}$$

$$80 \text{ MHz} \leq \frac{\text{MCLK} \times K}{P} \leq 110 \text{ MHz}$$

$$4 \leq J \leq 55$$

- When PLL is enabled and $D \neq 0$, the following condition must be satisfied

$$10 \text{ MHz} \leq \frac{\text{MCLK}}{P} \leq 20 \text{ MHz}$$

$$80 \text{ MHz} \leq \frac{\text{MCLK} \times K}{P} \leq 110 \text{ MHz}$$

$$4 \leq J \leq 11$$

Example 1:

For $\text{MCLK} = 12 \text{ MHz}$ and $\text{Fsref} = 44.1 \text{ kHz}$

$P = 1$, $K = 7.5264 \Rightarrow J = 7$, $D = 5264$

Example 2:

For $\text{MCLK} = 12 \text{ MHz}$ and $\text{Fsref} = 48.0 \text{ kHz}$

$P = 1$, $K = 8.192 \Rightarrow J = 8$, $D = 1920$

MONO AUDIO ADC**Analog Front End**

The analog front end of the audio ADC consists of an analog MUX and a programmable gain amplifier (PGA). The MUX can connect either the MICIN or AUX signal through the PGA to the ADC for audio recording. The 'AIC26 also has an option of choosing both MICIN and AUX as a differential input pair. The 'AIC26 also includes a microphone bias circuit, which can source up to 4.7-mA current and is programmable to a 2-V or 2.5-V level. The bias block is powered down when both the ADC and analog mixer blocks are powered down.

Because of the oversampling nature of the audio ADC and the integrated digital decimation filtering, requirements for analog antialiasing filtering are very relaxed. The 'AIC26 integrates a second order analog antialiasing filter with 20-dB attenuation at 1 MHz. This filter, combined with the digital decimation filter, provides sufficient antialiasing filtering without requiring any external components.

The PGA allows analog gain control from 0 dB to 59.5 dB in steps of 0.5 dB. The PGA gain changes are implemented with an internal soft-stepping algorithm that only changes the actual volume level by one 0.5-dB step every one or two ADC output samples, depending on the register programming. This soft-stepping ensures that volume control changes occur smoothly with no audible artifacts. On reset, the PGA gain defaults to a mute condition, and on power down, the PGA soft-steps the volume to mute before shutting down. A read-only flag (D0 control register 04H/Page2) is set whenever the gain applied by PGA equals the desired value set by the register. The soft-stepping control can be disabled by programming D15=1 in register 1DH of Page02. When soft-stepping is enabled, the MCLK signal to the device should not be changed until the ADC power-down flag is set. When the flag is set, the internal soft-stepping process and power-down sequence is complete, and the MCLK can be stopped if desired.

Delta-Sigma ADC

The analog-to-digital converter is a delta-sigma modulator with 128 times oversampling ratio. The ADC can support a maximum output rate of 53 kHz.

Decimation Filter

The audio ADC includes an integrated digital decimation filter that removes high-frequency content and downsamples the audio data from an initial sampling rate of 128 times F_s to the final output sampling rate of F_s . The decimation filter provides a linear phase output response with a group delay of $17/F_s$. The -3-dB bandwidth of the decimation filter extends to $0.45 F_s$ and scales with the sample rate (F_s)

Automatic Gain Control (AGC)

Automatic gain control (AGC) can be used to maintain nominally constant output signal amplitude when recording speech signals. This circuitry automatically adjusts the PGA gain as the input signal becomes overly loud or very weak, such as when a person speaking into a microphone moves closer or farther from the microphone. The AGC algorithm has several programmable settings, including target gain, attack and decay time constants, noise threshold, and maximum PGA gain applicable that allow the algorithm to be fine tuned for any particular application. The algorithm uses the absolute average of the signal (which is the average of the absolute value of the signal) as a measure of the nominal amplitude of the output signal.

Target gain represents the nominal output level at which the AGC attempts to hold the ADC output signal level. The 'AIC26 allows programming of eight different target gains, which can be programmed from -5.5 dB to -24 dB relative to a full-scale signal. Since the 'AIC26 reacts to the signal absolute average and not to peak levels, it is recommended that the larger gain be set with enough margin to avoid clipping at the occurrence of loud sounds.

Attack time determines how quickly the AGC circuitry reduces the PGA gain when the input signal is too loud. It can be varied from 8 ms to 20 ms.

Decay time determines how quickly the PGA gain is increased when the input signal is too low. It can be varied in the range from 100 ms to 500 ms.

Noise threshold is the minimum amplitude for the input signal that the AGC considers as a valid signal. If the average amplitude of the incoming signal falls below this value, the AGC considers it as silence and brings down the gain to 0 dB in steps of 0.5 dB for every FS. It also sets the noise threshold flag. The gain stays at 0 dB until the average amplitude of the input signal rises above the noise threshold value. This ensures that noise does not get amplified in the absence of a valid input speech signal. The noise threshold level is programmable between -60 dB and -90 dB relative to full scale. This operation includes debounce and hysteresis to avoid having the AGC gain cycle from high gain to 0 dB when the signal amplitude is close to the noise threshold level. When the noise threshold flag is set, the status of the gain applied by the AGC and the saturation flag should be ignored.

Maximum input gain applicable allows the user to restrict the maximum gain applied by the AGC. This can be used for limiting PGA gain in situations where environmental noise is greater than the programmed noise threshold. Depending on the noise threshold setting, the value of the maximum input gain applicable can be programmed between 0 dB and 59.5 dB in steps of 0.5 dB as shown in Table 1.

Table 1. Input Gain Settings

NOISE THRESHOLD	ALLOWED RANGE FOR THE MAXIMUM INPUT GAIN
-60 dB	0 dB to 59.5 dB
-70 dB	11.5 dB to 59.5 dB
-80 dB	21.5 dB to 59.5 dB
-90 dB	31.5 dB to 59.5 dB

See Table 2 for various AGC programming options.

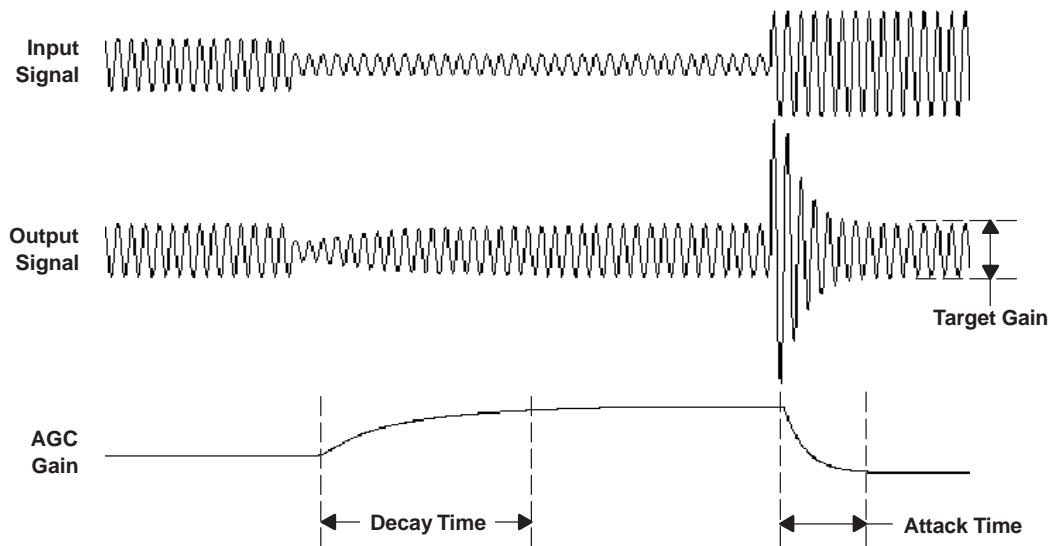

Figure 18. AGC Characteristics

Table 2. AGC Settings

	MIC INPUT	
	BIT	CONTROL REGISTER
AGC enable	D0	01H
Target gain	D7–D5	01H
Time constants (attack and decay time)	D4–D1	01H
Noise threshold	D5–D4	06H
Noise threshold flag	D11	04H
Hysteresis	D10–D9	1DH
Debounce time (normal to silence mode)	D8–D6	1EH
Debounce time (silence to normal mode)	D5–D3	1EH
Max input gain applicable	D15–D9	1EH
Gain applied by AGC	D15–D8	01H
Saturation flag	D0	04H
Clip stepping enable	D3	06H

NOTE: All settings shown in Table 2 are located in Page2 of the control registers.

STEREO AUDIO DAC

Each channel of the stereo audio DAC consists of a digital audio processing block, a digital interpolation filter, digital delta-sigma modulator, and an analog reconstruction filter. The DAC is designed to provide enhanced performance at low sample rates through increased oversampling and image filtering, thereby keeping quantization noise generated within the delta-sigma modulator and signal images strongly suppressed within the audio band to beyond 20 kHz. This is realized by keeping the upsampled rate constant at $128 \times F_{sref}$ and changing the oversampling ratio as the input sample rate is changed. For F_{sref} of 48 kHz, the digital delta-sigma modulator always operates at a rate of 6.144 MHz. This ensures that quantization noise generated within the delta-sigma modulator stays low within the frequency band below 20 kHz at all sample rates. Similarly, for F_{sref} rate of 44.1 kHz, the digital delta-sigma modulator always operates at a rate of 5.6448 MHz.

Digital Audio Processing

The DAC channel consists of optional filters for de-emphasis and bass, treble, midrange level adjustment, or speaker equalization. The de-emphasis function is only available for sample rates of 32 kHz, 44.1 kHz, and 48 kHz. The transfer function consists of a pole with time constant of 50 μ s and a zero with time constant of 15 μ s. Frequency response plots are given in the *Audio Codec Filter Frequency Responses* section of this data sheet. The de-emphasis filter can be enabled or bypassed depending on bit D0 of register 05H/Page2.

The DAC digital effects processing block also includes a fourth order digital IIR filter with programmable coefficients (one set per channel). The filter is implemented as cascade of two biquad sections with frequency response given by:

$$\left(\frac{N_0 + 2 \times N_1 \times z^{-1} + N_2 \times z^{-2}}{32768 - 2 \times D_1 \times z^{-1} - D_2 \times z^{-2}} \right) \left(\frac{N_3 + 2 \times N_4 \times z^{-1} + N_5 \times z^{-2}}{32768 - 2 \times D_4 \times z^{-1} - D_5 \times z^{-2}} \right)$$

The N and D coefficients are fully programmable, and the entire filter can be enabled or bypassed depending on bit D1 of register 05H/Page2. The coefficients for this filter implement a variety of sound effects, with bass-boost or treble boost being the most commonly used in portable audio applications. The default N and D coefficients in the part are given by:

$$\begin{aligned} N_0 = N_3 = 27619 & & D_1 = D_4 = 32131 \\ N_1 = N_4 = -27034 & & D_2 = D_5 = -31506 \\ N_2 = N_5 = 26461 & & \end{aligned}$$

and implement a shelving filter with 0 dB gain from dc to approximately 150 Hz, at which point it rolls off to a 3-dB attenuation for higher frequency signals, thus giving a 3-dB boost to signals below 150 Hz. The N and D coefficients are represented by 16-bit twos complement numbers with values ranging from –32768 to +32767. Frequency response plots are given in the *Audio Codec Filter Frequency Responses* section of this data sheet.

Interpolation Filter

The interpolation filter upsamples the output of the digital audio processing block by the required oversampling ratio. It provides a linear phase output with a group delay of 21/Fs.

In addition, a digital interpolation filter provides enhanced image filtering and reduces signal images caused by the upsampling process that are below 20 kHz. For example, upsampling an 8-kHz signal produces signal images at multiples of 8 kHz (i.e., 8 kHz, 16 kHz, 24 kHz, etc). The images at 8 kHz and 16 kHz are below 20 kHz and still audible to the listener; therefore, they must be filtered heavily to maintain good output quality. The interpolation filter is designed to maintain at least 65-dB rejection of images that land below 7.455 Fs. In order to utilize the programmable interpolation capability, the Fsref should be programmed to a higher rate (restricted to be in the range of 39 kHz to 53 kHz when the PLL is in use), and the actual Fs is set using the dividers in bit D5–D3/REG–00H/Page2. For example, if Fs = 8 kHz is required, then Fsref can be set to 48 kHz, and the DAC Fs set to Fsref/6. This ensures that all images of the 8-kHz data are sufficiently attenuated well beyond the ~20-kHz audible frequency range.

Delta-Sigma DAC

The audio digital-to-analog converter incorporates a third order multibit delta-sigma modulator followed by an analog reconstruction filter. The DAC provides high-resolution, low-noise performance, using oversampling and noise shaping techniques. The analog reconstruction filter design consists of a 6 tap analog FIR filter followed by a continuous time RC filter. The analog FIR operates at a rate of 128 x Fsref (6.144 MHz when Fsref = 48 kHz, 5.6448 MHz when Fsref = 44.1 kHz). Note that the DAC analog performance may be degraded by excessive clock jitter on the MCLK input. Therefore, care must be taken to keep jitter on this clock to a minimum.

DAC Digital Volume Control

The DAC has a digital volume control block, which implements programmable gain. The volume level can be varied from 0 dB to –63.5 dB in 0.5 dB steps. In addition, there is an independent mute bit for each channel. The volume level of both channels can also be changed simultaneously by the master volume control. The gain is implemented with a soft-stepping algorithm, which only changes the actual volume by one step per input sample, either up or down, until the desired volume is reached. The rate of soft-stepping can be slowed to one step per two input samples through bit D1 of control register 04H/Page2.

Because of soft-stepping, the host does not know when the DAC has been actually muted. This may be important if the host wishes to mute the DAC before making a significant change, such as changing sample rates. In order to help with this situation, the AIC26 provides a flag back to the host via a read-only register bit (D2–D3 of control register 04H/Page2) that alerts the host when the part has completed the soft-stepping and the actual volume has reached the desired volume level. The soft-stepping feature can be disabled by programming D14=1 in register 1DH in Page02. If soft-stepping is enabled, the MCLK signal to the device should not be changed until the DAC power-down flag is set. When this flag is set, the internal soft-stepping process and power-down sequence is complete, and the MCLK can be stopped if desired.

The 'AIC26 also includes functionality to detect when the user switches are on or off the de-emphasis or digital audio processing functions, to first (1) soft-mute the DAC volume control, (2) change the operation of the digital effects processing, and (3) soft-unmute the part. This avoids any possible pop/clicks in the audio output due to instantaneous changes in the filtering. A similar algorithm is used when first powering up or down the DAC. The circuit begins operation at power up with the volume control muted, then soft-steps it up to the desired volume level. At power down, the logic first soft-steps the volume down to a mute level, then powers down the circuitry.

DAC Power Down

The DAC power-down flag (D6 of REG05H/Page2) along with D10 of REG05H/Page2 denotes the power-down status of the DAC according to Table 3.

Table 3. DAC Powerdown Status

[D10,D6]	POWERUP / DOWN STATE OF DAC
[0,0]	DAC is in stable power-up state
[0,1]	DAC is in the process of powering up. The length of this state is determined by PLL and output driver power-up delays controlled by register programming.
[1,0]	DAC is in the process of powering down. The length of this state is determined by soft-stepping of volume control block and DAC pop reduction sequencing controlled by register programming.
[1,1]	DAC is in a stable power-down state.

AUDIO OUTPUT DRIVERS

The 'AIC26 features audio output drivers which can be configured in either low power mode or high power mode depending on the load and output power required. By default, at reset the output drivers are configured in low power mode. In this mode, the output drivers can drive a full-scale line-level signal into loads of 10 k Ω minimum or drive moderate amplitude signals into loads of 16 Ω minimum.

The output drivers can also be configured in high power mode by setting bit D12 of Reg05H/Page2 to 1. In this mode, each output driver can deliver up to 30 mW per channel into a headphone speaker load of 16 Ω . The headphones can be connected in a single-ended configuration using ac-coupling capacitors, or the capacitors can be removed and virtual ground (VGND) powered for a capless output connection. The typical headphone jack configuration for these two modes is shown in Figure 21. Note that the VGND amplifier must be powered if the capless configuration is used.

In the case of an ac-coupled output, the value of the capacitors is typically chosen based on the amount of low-frequency cut that can be tolerated. The capacitor in series with the load impedance forms a high-pass filter with -3 dB cutoff frequency of $1/(2\pi RC)$ in Hz, where R is the impedance of the headphones. Use of an overly small capacitor reduces low-frequency components in the signal output and leads to low-quality audio. When driving 16- Ω headphones, capacitors of 220- μ F (a commonly used value) result in a high-pass filter cutoff frequency of 45 Hz, although reducing these capacitors to 50 μ F results in a cutoff frequency of 199 Hz, which is generally considered noticeable when playing music. The cutoff frequency is reduced to half of the above values if 32- Ω headphones are used instead of 16 Ω .

The 'AIC26 programmable digital effects block can be used to help reduce the size of capacitors needed by implementing a low frequency boost function to help compensate for the high-pass filter introduced by the ac-coupling capacitors. For example, by using 50- μ F capacitors and setting the 'AIC26 programmable filter coefficients as shown below, the frequency response can be improved as shown in Figure 20.

Filter coefficients (use the same for both channels):

$$N0 = 32767, N1 = -32346, N2 = 31925, N3 = 32767, N4 = 0, N5 = 0$$

$$D0 = 32738, D1 = -32708, D4 = 0, D5 = 0$$

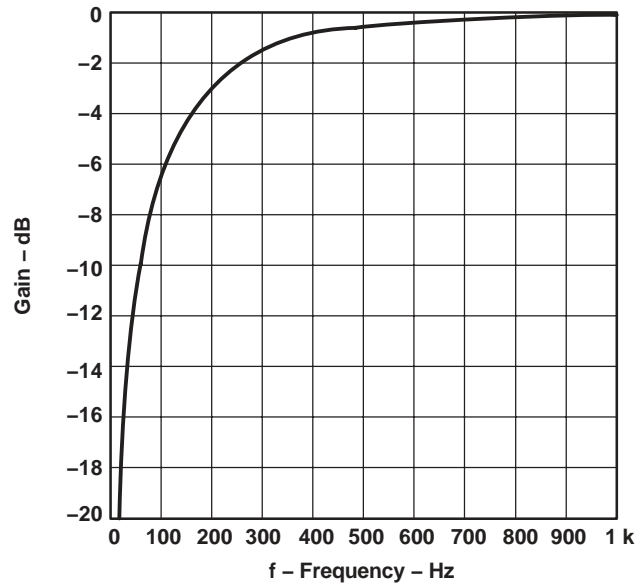

Figure 19. Uncompensated Response For 16-Ω Load and 50-μF Decoupling Capacitor

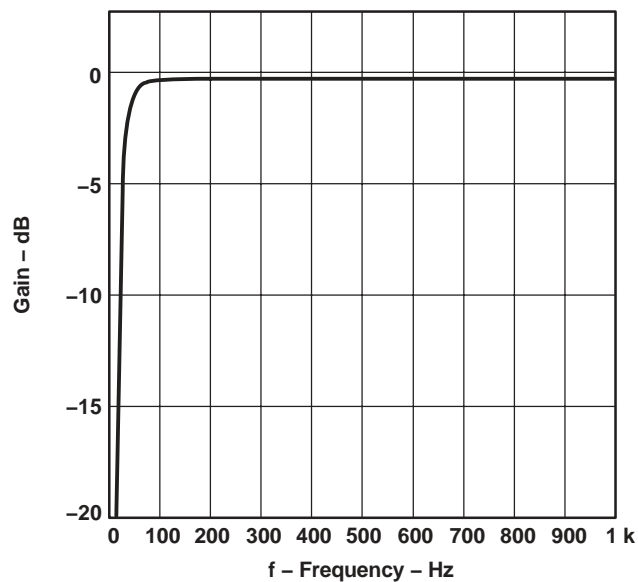

Figure 20. Frequency Response For 16-Ω Load and 50-μF Decoupling Capacitor After Gain Compensation Using a Suggested Set of Coefficients for Audio Effects Filter

Using the capless output configuration eliminates the need for these capacitors and removes the accompanying high-pass filter entirely. However, this configuration does have one drawback – if the RETURN terminal of the headphone jack (which is wired to the 'AIC26 VGND pin) is ever connected to a ground, that is shorted to the 'AIC26 ground pin, then the VGND amplifier enters short-circuit protection, and the audio output does not function properly.

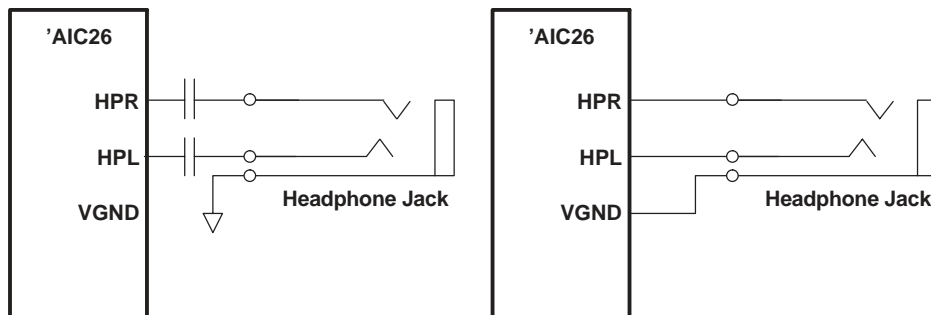

Figure 21. Headphone Configurations, AC-Coupled (left) and Capless (right)

The audio output drivers in high power mode can also be configured to drive a mono differential signal into a speaker load of 8-Ω minimum. The speaker load should be connected differentially between the HPR and HPL outputs. Several options are possible for playback of DAC data in this case. If a stereo digital signal is available, this signal can be sent in normal stereo fashion to the audio DAC. The programmable digital effects filters can then be used to invert one channel, so that the signal applied across the speaker load is (LEFT + RIGHT), or effectively a mono-mix of the two channels. A simple example of how to implement this inversion using the programmable filters is to set the coefficients as follows:

Left-channel coefficients: N0=32767, N1=0, N2=0, N3=32767, N4=0, N5=0
D1=0, D2=0, D4=0, D5=0

Right-channel coefficients: N0=-32767, N1=0, N2=0, N3=32767, N4=0, N5=0
D1=0, D2=0, D4=0, D5=0

This provides no spectral shaping; it only inverts the right channel relative to the left channel, such that the signals at HPL and HPR are (LEFT) and (-RIGHT), with the signal across the speaker then being LEFT+ RIGHT. In a general case when spectral shaping is also desired, the inversion can be accomplished simply by setting N0, N1, and N2 coefficients of one channel to the negative of the values set for the other channel. Note that the programmable filtering must be enabled by setting bit D1/REG-05H/Page2 to 1.

To enable the output drivers to deliver higher output power, the DAC output swing should be set to its highest level by setting bit D10-D9/REG-06H/Page2 to 11. It is possible to increase power even further by disabling the built-in short-circuit protection by programming bit D8 of Reg1DH/Page2 to 1. In this case care must be taken so a short-circuit at the output does not occur. Figure 22 shows a typical jack configuration using a capless output configuration. In this configuration, the 'AIC26 drives the loudspeaker whenever headphones are not inserted in the jack and drives the headphones whenever it is inserted in the jack.

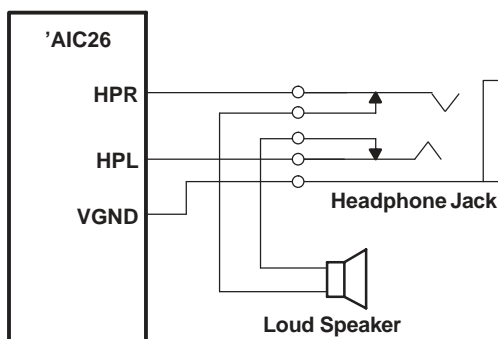

Figure 22. Speaker Connection

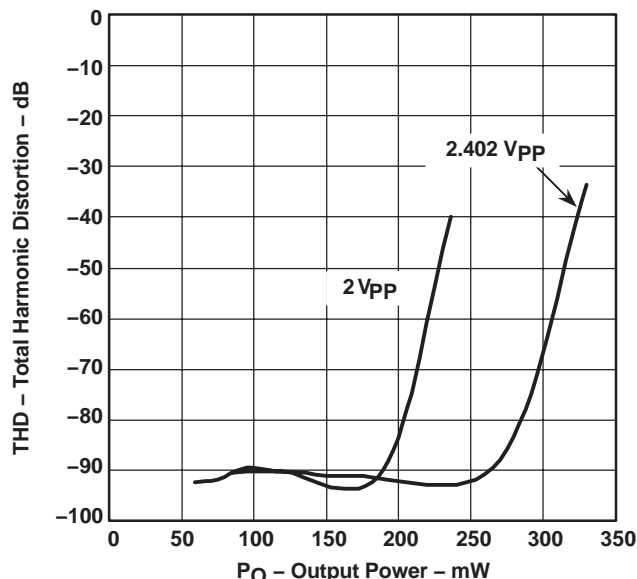

Figure 23. THD vs Output Power Delivered to an an 8-Ω Load (25°C, AVDD = DRVDD = 3.3 V, DVDD = 1.8 V, DAC Output Swing Set to 2 V and 2.4V, and Short-Circuit Protection Disabled)

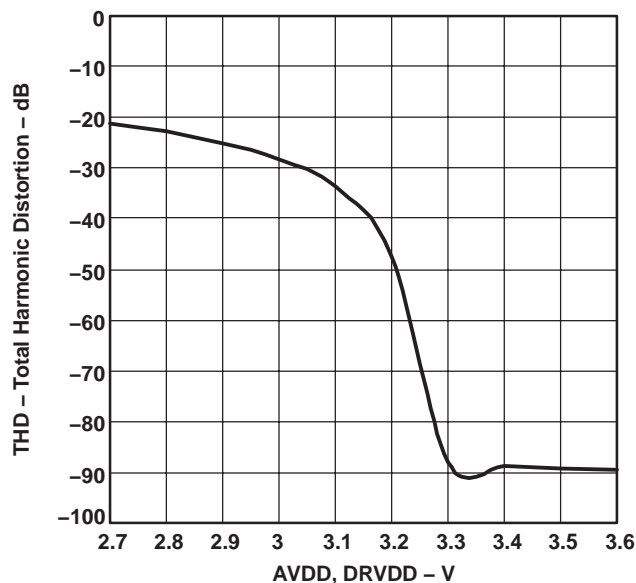

Figure 24. THD vs AVDD, DRVDD Supply Voltage (25°C When Driving a -1 dB, 1-kHz Sinewave From the DAC Into an 8-Ω Load, with DAC Output Swing Set to 2.4 V, and Short-Circuit Protection Disabled)

The 'AIC26 incorporates a programmable short-circuit detection/protection function with different modes of operation. During the insertion or removal of a headphone plug from the jack, the output pins of the drivers may be accidentally shorted, causing the part to potentially draw a huge current, which may cause the power supply voltages to dip. Bits D8–D7 of REG–1DH/Page2 control how the short-circuit detection/protection operates in the 'AIC26. One option is to fully disable short-circuit protection, which also enables the audio output drivers to deliver more power to a low-impedance load (such as an 8-Ω speaker). However, care must be taken to prevent any short-circuit from occurring while the part is in this mode.

A second programmable configuration enables current-limiting in the audio output drivers, so that excessive currents cannot be provided if the outputs are shorted. It also enables the internal short-circuit detection function, which can detect excess current being drawn from the drivers and set a short-circuit detect flag (Page2, REG–1DH, bit D6). This flag can be read by the user to power down the drivers if desired. This flag is cleared only if the short-circuit condition is removed. If the user does not monitor this flag and powers down the drivers when a short-circuit occurs, the current-limiting prevents excessive currents from being drawn, but power dissipation is higher due to this limited current flowing through the short.

In a third programmable configuration, the 'AIC26 can be programmed to monitor and automatically power down the audio output drivers upon detection of a short-circuit condition (Page2, REG–1DH, bit D7), in addition to setting the short-circuit flag in Page2, REG–1DH, bit–D6. When the device has detected a short and resulted in this condition, the short-circuit flag is cleared when all the routings to the speaker driver are disabled (i.e., DAC, Analog Mixer, and Keyclick blocks are powered down by user).

AUDIO OUTPUT DRIVER POWER-ON POP REDUCTION SCHEME

The 'AIC26 implements a pop reduction scheme to reduce audible artifacts during power up and power down of the audio output drivers. This scheme can be controlled by programming bits D2 and D1 of REG1EH/Page2. By default, the driver pop reduction scheme is enabled and can be disabled by programming bit D2 of Reg1EH/Page2 to 1. When this scheme is enabled and the virtual ground connection is not used (VGND amplifier is powered down), the audio output driver slowly charges up any external ac-coupling capacitors to reduce audible artifacts. Bit D1 of REG1EH/Page2 provides control of the charging time for the ac-coupling capacitor as either 0.8 sec or 4 sec. When the virtual ground amplifier is powered up and used, the external ac-coupling capacitor is eliminated, and the power up time becomes 1 ms. This scheme takes effect whenever the audio output drivers are powered up due to enabling any of the DAC, the Analog Mixer, or the Keyclick Generator.

Pop Reduction for DAC Routing

Whenever the audio DAC is powered on or off, a slight change in the output dc offset voltage may occur and can be heard as a weak pop in the output. In order to reduce this artifact, the 'AIC26 implements a DAC pop reduction scheme, which is programmable using bits D5–D2 in REG–1DH/Page2. Bit D5 enables the scheme, which implements a slow transition between the starting dc level and the final dc level. For best results, program bits D4–D2 in REG1DH/Page2 to 100.

AUDIO MIXING

Digital Sidetone

The digital sidetone control attenuates the output from the ADCs decimation filter and routes its output to be mixed with the DAC digital input. If bit D7 of REG–03H/Page2 is reset, the output of the sidetone control is mixed with the stereo DAC input. Care must be taken while selecting the digital sidetone gain so that the output of the digital mixer is not overloaded. The digital sidetone block implements gains from 0 dB to –48 dB in steps of 1.5 dB. Gain changes are implemented at zero-crossings of the signal to avoid any audible artifacts. The digital sidetone block is automatically internally disabled if ADC and DAC are operating at different sampling rates, or if the DAC is powered down.

Analog Mixer

The analog mixer can be used to route the analog input selected for the ADC (MICIN or AUX) through an analog volume control and then mix it with the audio DAC output. The analog mixer feature is available only if single-ended MICIN or AUX is selected as the input to the ADC, not when the ADC input is configured in fully-differential mode. This feature is available even if the ADC and DAC are powered down. The analog volume control in this path has a gain range from 12 dB to –34.5 dB in 0.5-dB steps plus mute and includes soft-stepping logic. The internal oscillator is used for soft-stepping whenever the ADC and DAC are powered down.

KEYCLICK

A special circuit has been included for inserting a square-wave signal into the analog output signal path based on register control. This functionality is intended for generating keyclick sounds for user feedback. Register 04H/Page2 contains bits that control the amplitude, frequency, and duration of the square-wave signal. The frequency of the signal can be varied from 62.5 Hz to 8 kHz and its duration can be programmed from 2 periods to 32 periods. Whenever this register is written, the square-wave is generated and coupled into the audio output, going to both audio outputs. The keyclick enable bit D15 of control register 04H/Page2 is reset after the duration of keyclick is played out. This capability is available even when the ADC and DAC are powered down.

SPI DIGITAL INTERFACE

All 'AIC26 control registers are programmed through a standard SPI bus. The SPI allows full-duplex, synchronous, serial communication between a host processor (the master) and peripheral devices (slaves). The SPI master generates the synchronizing clock and initiates transmissions. The SPI slave devices depend on a master to start and synchronize transmissions.

A transmission begins when initiated by a master SPI. The byte from the master SPI begins shifting in on the slave SPIDIN (MOSI) pin under the control of the master serial clock. As the byte shifts in on the SPIDIN pin, a byte shifts out on the SPIDOUT (MISO) pin to the master shift register.

The idle state of the serial clock for the 'AIC26 is low, which corresponds to a clock polarity setting of 0 (typical microprocessor SPI control bit CPOL = 0). The 'AIC26 interface is designed so that with a clock phase bit setting of 1 (typical microprocessor SPI control bit CPHA = 1), the master begins driving its MOSI pin and the slave begins driving its SPIDOUT pin on the first serial clock edge. The \overline{SS} pin can remain low between transmissions; however, the 'AIC26 only interprets command words which are transmitted after the falling edge of \overline{SS} .

OPERATION–AUXILIARY MEASUREMENT

Data Format

The 'AIC26 auxiliary output data is in unsigned binary format and can be read from the registers over the SPI interface.

Reference

The 'AIC26 has an internal voltage reference that can be set to 1.25 V or 2.5 V, through the reference control register.

The internal reference voltage should only be used in the single-ended mode for battery monitoring, temperature measurement, and for measuring the auxiliary inputs.

An external reference can also be applied to the VREF pin, and the internal reference can be turned off.

Variable Resolution

The 'AIC26 provides three different resolutions for the A/D converter: 8-, 10- or 12-bits. Performing the conversions at lower resolution reduces the amount of time it takes for the A/D converter to complete its conversion process, which lowers power consumption.

Conversion Clock and Conversion Time

The 'AIC26 contains an internal 8-MHz clock, which is used to drive the state machines inside the device that perform the many functions of the part. This clock is divided down to provide a clock to run the A/D converter. The division ratio for this clock is set in the A/D converter control register. The ability to change the conversion clock rate allows the user to choose the optimal value for resolution, speed, and power. If the 8-MHz clock is used directly, the A/D converter is limited to 8-bit resolution; using higher resolutions at this speed may not result in accurate conversions. Using a 4-MHz conversion clock is suitable for 10-bit resolution; 12-bit resolution requires that the conversion clock run at 1 or 2 MHz.

Regardless of the conversion clock speed, the internal clock runs nominally at 8 MHz. The conversion clock speed, however, plays an important role in the time it takes for a conversion to complete, as a certain number of internal clock cycles is needed for proper sampling of the signal. Throughout this data sheet, internal and conversion clock cycles are used to describe the times that many functions take to execute. Considering the total system design, these times must be taken into account by the user.

When both the audio ADC and DAC are powered down, the auxiliary A/D uses an internal oscillator for conversions. However, to save power whenever audio ADC or DAC are powered up, the internal oscillator is powered down and MCLK and BCLK are used to clock the auxiliary A/D.

The 'AIC26 uses the programmed value of Page2, Reg 06H D13 and the PLL programmability to derive a clock from MCLK. The various combinations are listed in Table 4.

Table 4. Conversion Clock Frequency

	Page2, Reg 06H, D13 = 0	Page2, Reg 06H, D13 = 1
PLL enabled	$\frac{MCLK \times K \times 13}{P \times 160}$	$\frac{MCLK \times K \times 17}{P \times 192}$
PLL disabled	$\frac{MCLK \times 13}{Q \times 10}$	$\frac{MCLK \times 17}{Q \times 12}$

Temperature Measurement

In some applications, such as battery recharging, a measurement of ambient temperature is required. The temperature measurement technique used in the 'AIC26 relies on the characteristics of a semiconductor junction operating at a fixed current level. The forward diode voltage (V_{BE}) has a well-defined characteristic versus temperature. The ambient temperature can be predicted in applications by knowing the 25°C value of the V_{BE} voltage and then monitoring the delta of that voltage as the temperature changes.

The 'AIC26 offers two modes of temperature measurement. The first mode requires a single reading to predict the ambient temperature. A diode, as shown in Figure 25, is used during this measurement cycle. This voltage is typically 600 mV at 25°C with a 20- μ A current through it. The absolute value of this diode voltage can vary a few millivolts. During the final test of the end product, the diode voltage must be stored at a known temperature. Further calibration can be done to calculate the precise temperature coefficient of the particular device. This method has a temperature resolution of approximately 0.3 °C/LSB and accuracy of approximately 6°C.

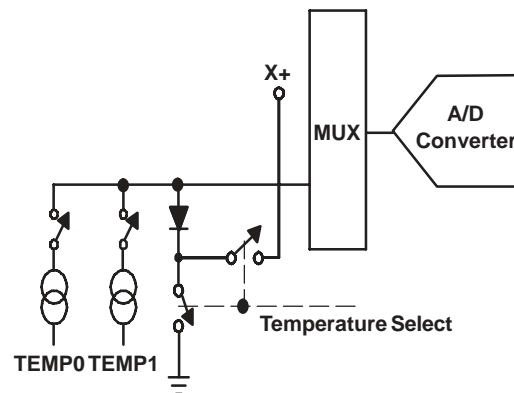

Figure 25. Functional Block Diagram of Temperature Measurement Mode

The second mode uses a two-measurement (differential) method. This mode requires a second conversion with a current 82 times larger. The voltage difference between the first (TEMP1) and second (TEMP2) conversion, using 82 times the bias current, is represented by:

$$\left(\frac{kT}{q}\right) \times \ln(N)$$

where:

N is the current ratio = 82

k = Boltzmann's constant ($1.38054 \cdot 10^{-23}$ electrons volts/degrees Kelvin)

q = the electron charge ($1.602189 \cdot 10^{-19}$ °C)

T = the temperature in degrees Kelvin

This method provides resolution of approximately 1.5°C/LSB and accuracy of approximately 5°C. The temperature measured by the 'AIC26 is an approximate number with an accuracy of 5°C to 6°C depending on the method used. Further, it has been found that the measurement varies significantly from device to device. Therefore, it is recommended that the user calibrate the temperature measurement during final system test.

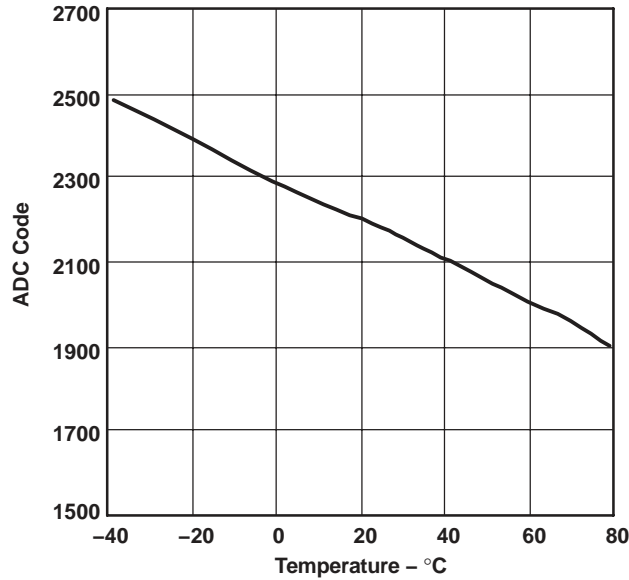

Figure 26. Typical Plot for Single Measurement Method

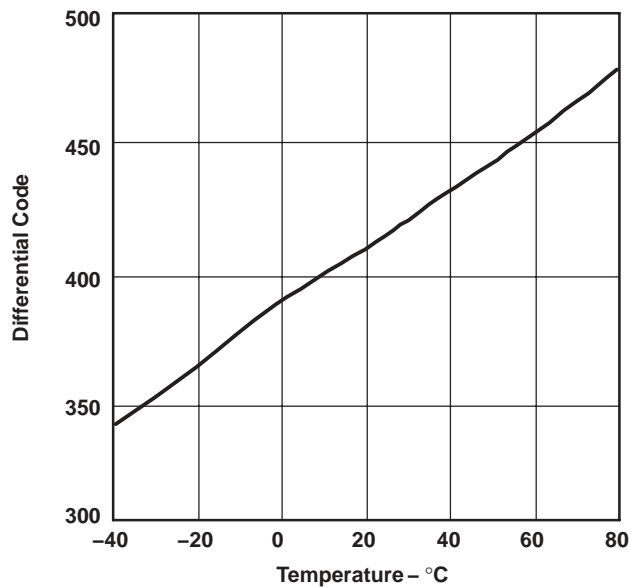

Figure 27. Typical Plot for Differential Measurement Method

Battery Measurement

An added feature of the 'AIC26 is the ability to monitor the battery voltage on the other side of a voltage regulator (dc/dc converter), as shown in Figure 28. The battery voltage can vary from 0.5 V to 6 V while maintaining the analog supply voltage to the 'AIC26 in the range of 2.7 V to 3.6 V. The input voltage (VBAT1 or VBAT2) is divided by a factor of 6 so that a 6.0-V battery voltage is represented as 1.0 V to the ADC. In order to minimize the power consumption, the divider is only on during the sampling of the battery input. If the battery conversion results in a ADC output code of B, the voltage at the battery pin can be calculated as

$$V_{bat} = (B/2^N) \times 6 \times V_{ref}$$

where N is the programmed resolution of ADC and Vref the programmed value of internal reference or the applied external reference.

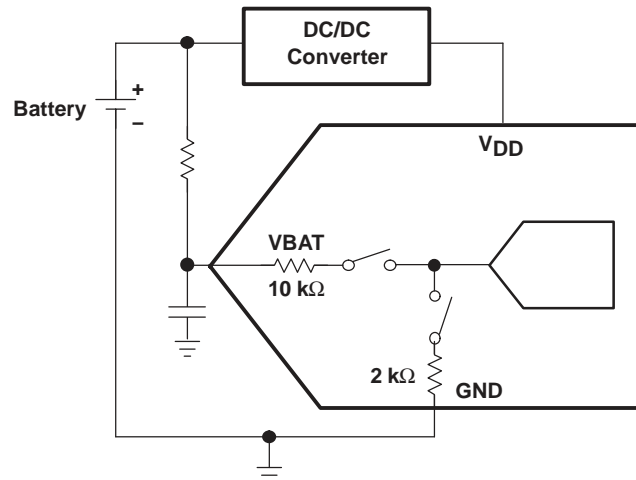

Figure 28. Battery Measurement Functional Block Diagram

For increased protection and robustness, TI recommends a minimum 100-Ω resistor be added in series between the system battery and the VBAT pin. The 100-Ω resistor causes an approximately 1% gain change in the battery voltage measurement, which can easily be corrected in software when the battery conversion data is read by the operating system.

See the *Conversion Time Calculation for the 'AIC26* section in this data sheet for timing diagrams and conversion time calculations.

Auxiliary Measurement

The auxiliary voltage input (AUX) can be measured in much the same way as the battery inputs. Applications might include external temperature sensing, ambient light monitoring for controlling the back-light, or sensing the current drawn from the battery. The auxiliary input can also be monitored continuously in scan mode.

See the *Conversion Time Calculation for the 'AIC26* section in this data sheet for timing diagrams and conversion time calculations.

Port Scan

If making measurements of BAT1, BAT2, and AUX is desired on a periodic basis, the port scan mode can be used. This mode causes the 'AIC26 to sample and convert both battery inputs and the auxiliary input. At the end of this cycle, the battery and auxiliary result registers contain the updated values. Thus, with one write to the 'AIC26, the host can cause three different measurements to be made.

See the *Conversion Time Calculation for the 'AIC26* section and the *Port Scan Operation* subsection in this data sheet for timing diagrams and conversion time calculations.

Hardware Reset

The device requires a low-to-high pulse on $\overline{\text{RESET}}$ after power up for correct operation. A hardware reset pulse initializes all the internal registers, counters, and logic.

Hardware Power Down

By default the $\overline{\text{PWD/ADWS}}$ pin is configured as a hardware power-down (active low) signal. The device powers down all the internal circuitry to save power. All the register contents are maintained. Some counters maintain their value. The user can optionally use this pin as ADWS (ADC word select) by register programming.

'AIC26 COMMUNICATION PROTOCOL

Register Programming

The 'AIC26 is entirely controlled by registers. An SPI master controls the reading and writing of these registers by the use of a 16-bit command, which is sent prior to the data for that register. The command is constructed as shown in Figure 29.

The command word begins with a R/W bit, which specifies the direction of data flow on the SPI serial bus. The following four bits specify the page of memory this command is directed to, as shown in Table 5. The next six bits specify the register address on that page of memory to which the data is directed. The last five bits are reserved for future use and should be written only with zeros.

Table 5. Page Addressing

PG3	PG2	PG1	PG0	PAGE ADDRESSED
0	0	0	0	0
0	0	0	1	1
0	0	1	0	2
0	0	1	1	Reserved
0	1	0	0	Reserved
0	1	0	1	Reserved
0	1	1	0	Reserved
0	1	1	1	Reserved
1	0	0	0	Reserved
1	0	0	1	Reserved
1	0	1	0	Reserved
1	0	1	1	Reserved
1	1	0	0	Reserved
1	1	0	1	Reserved
1	1	1	0	Reserved
1	1	1	1	Reserved

To read all the first page of memory, for example, the host processor must send the command 0x8000 to the 'AIC26 – this specifies a read operation beginning at page 0, address 0. The processor can then start clocking data out of the 'AIC26. The 'AIC26 automatically increments its address pointer to the end of the page; if the host processor continues clocking data out past the end of a page, the 'AIC26 sends back the value 0xFFFF.

Likewise, writing to page 1 of memory consists of the processor writing the command 0x0800, which specifies a write operation, with PG0 set to 1, and all the ADDR bits set to 0. This results in the address pointer pointing at the first location in memory on Page 1. See the section on the 'AIC26 memory map for details of register locations

BIT 15 MSB	BIT 14	BIT 13	BIT 12	BIT 11	BIT 10	BIT 9	BIT 8	BIT 7	BIT 6	BIT 5	BIT 4	BIT 3	BIT 2	BIT 1	BIT 0 LSB
R/W*	PG3	PG2	PG1	PG0	ADDR5	ADDR4	ADDR3	ADDR2	ADDR1	ADDR0	0	0	0	0	0

Figure 29. 'AIC26 Command Word

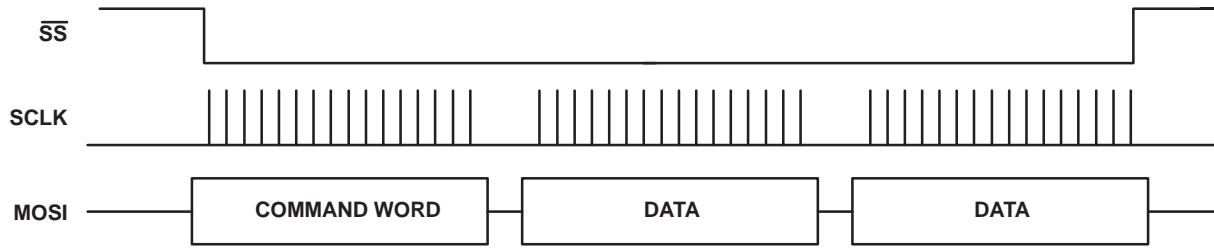

Figure 30. Write Operation for 'AIC26 SPI Interface

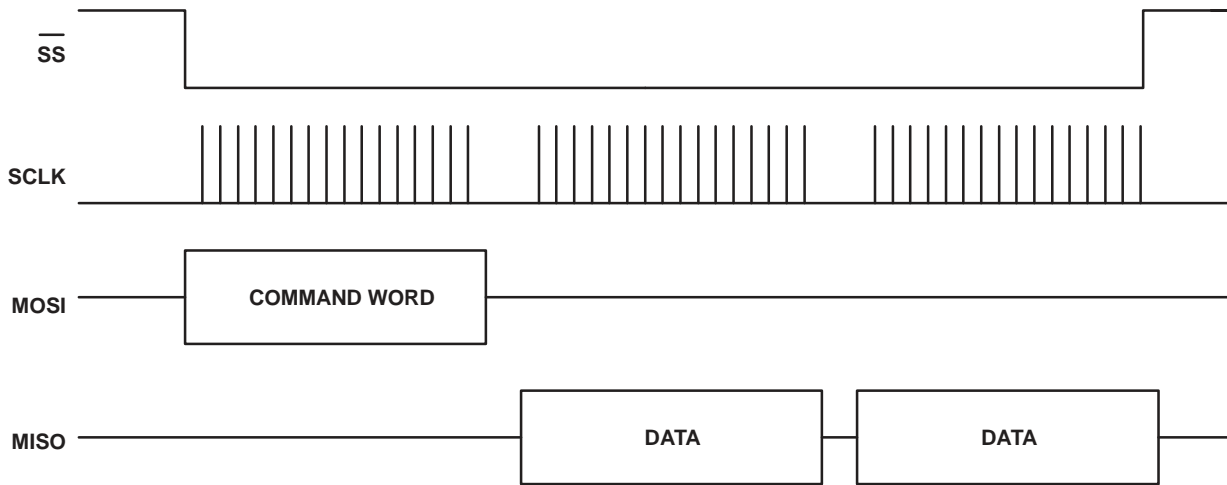

Figure 31. Read Operation for 'AIC26 SPI Interface

'AIC26 MEMORY MAP

The 'AIC26 has several 16-bit registers which allow control of the device as well as providing a location for results from the 'AIC26 to be stored until read by the host microprocessor. These registers are separated into three pages of memory in the 'AIC26: a data page (Page 0) and control pages (Page 1 and Page 2). The memory map is shown in Table 6.

Table 6. Memory Map

Page 0: Auxiliary Data Registers		Page 1: Auxiliary Control Registers		Page 2: Audio Control Registers	
ADDR	REGISTER	ADDR	REGISTER	ADDR	REGISTER
00	Reserved	00	AUX ADC	00	Audio Control 1
01	Reserved	01	Status	01	Codec ADC Gain
02	Reserved	02	Reserved	02	Codec DAC Gain
03	Reserved	03	Reference	03	Codec Sidetone
04	Reserved	04	Reset	04	Audio Control 2
05	BAT1	05	Reserved	05	Codec Power Control
06	BAT2	06	Reserved	06	Audio Control 3
07	AUX	07	Reserved	07	Digital Audio Effects Filter Coefficients
08	Reserved	08	Reserved	08	Digital Audio Effects Filter Coefficients
09	TEMP1	09	Reserved	09	Digital Audio Effects Filter Coefficients
0A	TEMP2	0A	Reserved	0A	Digital Audio Effects Filter Coefficients
0B	Reserved	0B	Reserved	0B	Digital Audio Effects Filter Coefficients
0C	Reserved	0C	Reserved	0C	Digital Audio Effects Filter Coefficients
0D	Reserved	0D	Reserved	0D	Digital Audio Effects Filter Coefficients
0E	Reserved	0E	Reserved	0E	Digital Audio Effects Filter Coefficients
0F	Reserved	0F	Reserved	0F	Digital Audio Effects Filter Coefficients
10	Reserved	10	Reserved	10	Digital Audio Effects Filter Coefficients
11	Reserved	11	Reserved	11	Digital Audio Effects Filter Coefficients
12	Reserved	12	Reserved	12	Digital Audio Effects Filter Coefficients
13	Reserved	13	Reserved	13	Digital Audio Effects Filter Coefficients
14	Reserved	14	Reserved	14	Digital Audio Effects Filter Coefficients
15	Reserved	15	Reserved	15	Digital Audio Effects Filter Coefficients
16	Reserved	16	Reserved	16	Digital Audio Effects Filter Coefficients
17	Reserved	17	Reserved	17	Digital Audio Effects Filter Coefficients
18	Reserved	18	Reserved	18	Digital Audio Effects Filter Coefficients
19	Reserved	19	Reserved	19	Digital Audio Effects Filter Coefficients
1A	Reserved	1A	Reserved	1A	Digital Audio Effects Filter Coefficients
1B	Reserved	1B	Reserved	1B	PLL Programmability
1C	Reserved	1C	Reserved	1C	PLL Programmability
1D	Reserved	1D	Reserved	1D	Audio Control 4
1E	Reserved	1E	Reserved	1E	Audio Control 5
1F	Reserved	1F	Reserved	1F	Reserved

'AIC26 CONTROL REGISTERS

This section describes each of the registers shown in the memory map of Table 6. The registers are grouped according to the function they control. In the 'AIC26, bits in control registers can refer to slightly different functions depending on whether you are reading the register or writing to it.

'AIC26 Data Registers (Page 0)

The data registers in Page 0 of the 'AIC26 hold data results from auxiliary ADC. All of these registers default to 0000H on reset. These registers are *read only*.

BAT1, BAT2, AUX, TEMP1 and TEMP2 Registers

The results of all A/D conversions are placed in the appropriate data register. The data format of the result word, R, of these registers is right-justified, as follows:

BIT 15 MSB	BIT 14	BIT 13	BIT 12	BIT 11	BIT 10	BIT 9	BIT 8	BIT 7	BIT 6	BIT 5	BIT 4	BIT 3	BIT 2	BIT 1	BIT 0 LSB
0	0	0	0	R11 MSB	R10	R9	R8	R7	R6	R5	R4	R3	R2	R1	R0 LSB

All the updated data registers should be read back either with a single SPI transaction as shown in Figure 31 or by reading in descending order of address (i.e., higher address data first and lower address data next). For example, read the updated registers in order of AUX, BAT2, and then BAT1 instead of BAT1, BAT2, and then AUX.

PAGE 1 CONTROL REGISTER MAP

REGISTER 00H: ADC Control

BIT	NAME	READ/ WRITE	RESET VALUE	FUNCTION
D15		R	0	Reserved. Note: The value of this bit should always be set to zero.
D14	ADST	R/W	1(for read status) 0(for write status)	A/D Status. READ 0 => ADC is busy 1 => ADC is not busy (default) WRITE 0 => Normal mode. (default) 1 => Stop conversion and power down. Power down happens immediately
D13–10	ADSCM	R/W	0000	A/D Scan Mode. 0000 => No scan 0001 => Reserved 0010 => Reserved 0011 => Reserved 0100 => Reserved 0101 => Reserved 0110 => BAT1 input is converted, and the result is returned to the BAT1 data register. 0111 => BAT2 input is converted, and the result is returned to the BAT2 data register. 1000 => AUX input is converted, and the result is returned to the AUX data register. 1001 => Scan function: AUX input is converted and the result is returned to the AUX data register. Scan continues until stop bit is sent. 1010 => TEMP1 is converted, and the result is returned to the TEMP1 data register. 1011 => Port scan function: BAT1, BAT2, and AUX inputs are measured and the results returned to the appropriate data registers. 1100 => TEMP2 is converted, and the result is returned to the TEMP2 data register. 1101 => Reserved 1110 => Reserved 1111 => Reserved
D9–D8	RESOL	R/W	00	Resolution Control. The A/D converter resolution is specified with these bits. 00 => 12-bit resolution 01 => 8-bit resolution 10 => 10-bit resolution 11 => 12-bit resolution

BIT	NAME	READ/ WRITE	RESET VALUE	FUNCTION										
D7–D6	ADAVG	R/W	00	<p>Converter Averaging Control. These two bits allow you to specify the number of averages the converter performs selected by bit D0, which selects either mean filter or median filter.</p> <table> <tr> <td>Mean Filter</td> <td>Median filter</td> </tr> <tr> <td>00 => No average</td> <td>No average</td> </tr> <tr> <td>01 => 4–data average</td> <td>5–data average</td> </tr> <tr> <td>10 => 8–data average</td> <td>9–data average</td> </tr> <tr> <td>11 => 16–data average</td> <td>15–data average</td> </tr> </table>	Mean Filter	Median filter	00 => No average	No average	01 => 4–data average	5–data average	10 => 8–data average	9–data average	11 => 16–data average	15–data average
Mean Filter	Median filter													
00 => No average	No average													
01 => 4–data average	5–data average													
10 => 8–data average	9–data average													
11 => 16–data average	15–data average													
D5–D4	ADCR	R/W	00	<p>Conversion Rate Control. These two bits specify the internal clock rate which the A/D converter uses to perform a single conversion. These bits are the same whether reading or writing.</p> $t_{\text{conv}} = \frac{N + 4}{f_{\text{INTCLK}}}$ <p>where f_{INTCLK} is the internal clock frequency. For example, with 12-bit resolution and a 2-MHz internal clock frequency, the conversion time is 8.0 μs. This yields an effective throughput rate of 125 kHz.</p> <p>00 => 8-MHz internal clock rate (use for 8-bit resolution only) 01 => 4-MHz internal clock rate (use for 8-bit/10-bit resolution only) 10 => 2-MHz internal clock rate 11 => 1-MHz internal clock rate</p>										
D3–D1		R	000	Reserved.										
D0	AVGFS	R/W	0	<p>Average Filter select 0 => Mean filter 1 => Median filter</p>										

REGISTER 01H: Status Register

BIT	NAME	READ/ WRITE	RESET VALUE	FUNCTION
D15–D14	$\overline{\text{DAV}}$	R/W	10	Data Available. These two bits program the function of the $\overline{\text{DAV}}$ pin. 00 => Reserved 01 => Acts as data available (Active Low) only. The $\overline{\text{DAV}}$ goes low as soon as one set of ADC conversion is completed. For scan mode, $\overline{\text{DAV}}$ remains low as long as all the appropriate registers have not been read out. 10 => Reserved 11 => Reserved Note: D15–D14 should be programmed to 01 for the 'AIC26 to operate correctly.
D13	PWRDN	R	0	AUX–ADC Power down status 0 => AUX–ADC is active 1 => AUX–ADC stops conversion and powers down
D12		R	0	Reserved
D11	DAVAIL	R	0	Data Available Status 0 => No data available. 1 => Data is available(i.e., one set of conversion is done). Note:– This bit is cleared only after all the converted data has been completely read out.
D10–D7		R	0000	Reserved
D6	B1STAT	R	0	BAT1 Data Register Status 0 => No new data is available in BAT1 data register 1 => New data is available in BAT1 data register Note: This bit is cleared only after the converted data of BAT1 has been completely read out of the register.
D5	B2STAT	R	0	BAT2 Data Register Status 0 => No new data is available in BAT2 data register 1 => New data is available in BAT2 data register Note: This bit is cleared only after the converted data of BAT2 has been completely read out of the register.
D4	AXSTAT	R	0	AUX Data Register Status 0 => No new data is available in AUX data register 1 => New data is available in AUX data register Note: This bit is cleared only after the converted data of AUX has been completely read out of the register.
D3		R	0	Reserved
D2	T1STAT	R	0	TEMP1 Data Register Status 0 => No new data is available in TEMP1 data register 1 => New data is available in TEMP1 data register Note: This bit is cleared only after the converted data of TEMP1 has been completely read out of the register.
D1	T2STAT	R	0	TEMP2 Data Register Status 0 => No new data is available in TEMP2 data register 1 => New data is available in TEMP2 data register Note: This bit is cleared only after the converted data of TEMP2 has been completely read out of the register.
D0		R	0	Reserved

REGISTER 02H: Reserved

BIT	NAME	READ/ WRITE	RESET VALUE	FUNCTION
D15–D0		R	FFFFH	Reserved

REGISTER 03H: Reference Control

BIT	NAME	READ/ WRITE	RESET VALUE	FUNCTION
D15–D5		R	000H	Reserved
D4	VREFM	R/W	0	Voltage Reference Mode. This bit configures the VREF pin as either external reference or internal reference. 0 => External reference 1 => Internal reference
D3–D2	RPWUDL	R/W	00	Reference Power Up Delay. These bits allow a delay time for measurements to be made after the reference powers up, thereby ensuring that the reference has settled 00 => 0 μ s 01 => 100 μ s 10 => 500 μ s 11 => 1000 μ s Note: This is valid only when the device is programmed for internal reference and bit D1 = 1, i.e., reference is powered down between the conversions if not required.
D1	RPWDN	R/W	1	Reference Power Down. This bit controls the power down of the internal reference voltage. 0 => Powered up at all times. 1 => Powered down between conversions. Note: when D4 = 0, i.e., device is in external reference mode, then the internal reference is powered down always.
D0	IREFV	R/W	0	Internal Reference Voltage. This bit selects the internal voltage reference level for the TSC ADC. 0 => VREF = 1.25 V 1 => VREF = 2.50 V

REGISTER 04H: Reset Control

BIT	NAME	READ/ WRITE	RESET VALUE	FUNCTION
D15–D0	RSALL	R/W	FFFFH	Reset All. Writing the code 0xBB00, as shown below, to this register causes the 'AIC26 to reset all its registers to their default, power–up values. 1011101100000000 => Reset all registers Others => Do not write other sequences to this register.

REGISTER 05H: Reserved

BIT	NAME	READ/ WRITE	RESET VALUE	FUNCTION
D15–D0		R	0000H	Reserved

PAGE 2 CONTROL REGISTER MAP

REGISTER 00H: Audio Control 1

BIT	NAME	READ/ WRITE	RESET VALUE	FUNCTION
D15–D14	ADCHPF	R/W	00	ADC High Pass Filter 00 => Disabled 01 => –3dB point = 0.0045 x Fs 10 => –3dB point = 0.0125 x Fs 11 => –3dB point = 0.025 x Fs Note: Fs is ADC sample rate
D13–D12	ADCIN	R/W	00	ADC Input Mux 00 => ADC Input = Single-ended input MIC 01 => ADC Input = Single-ended input AUX 10 => ADC Input = Differential input MICIN and AUX 11 => ADC Input = Differential input MICIN and AUX
D11–D10	WLEN	R/W	00	Codec Word Length 00 => Word length = 16 bit 01 => Word length = 20 bit 10 => Word length = 24 bit 11 => Word length = 32 bit
D9–D8	DATFM	R/W	00	Digital Data Format 00 => I ² S mode 01 => DSP mode 10 => Right justified 11 => Left justified Note: Right justified, valid only when the ratio between DAC and ADC sample rate is an integer. e.g., ADC = 32 kHz and DAC = 24 kHz or vice-versa is invalid for right-justified mode.
D7–D6		R	00	Reserved
D5–D3	DACFS	R/W	000	DAC Sampling Rate 000 => DAC FS = Fsref/1 001 => DAC FS = Fsref/(1.5) 010 => DAC FS = Fsref/2 011 => DAC FS = Fsref/3 100 => DAC FS = Fsref/4 101 => DAC FS = Fsref/5 110 => DAC FS = Fsref/(5.5) 111 => DAC FS = Fsref/6 Note: Fsref can be set between 39 kHz and 53 kHz
D2–D0	ADCFS	R/W	000	ADC Sampling Rate 000 => ADC FS = Fsref/1 001 => ADC FS = Fsref/(1.5) 010 => ADC FS = Fsref/2 011 => ADC FS = Fsref/3 100 => ADC FS = Fsref/4 101 => ADC FS = Fsref/5 110 => ADC FS = Fsref/(5.5) 111 => ADC FS = Fsref/6 Note: Fsref can be set between 39 kHz and 53 kHz

REGISTER 01H: CODEC ADC Gain Control

BIT	NAME	READ/ WRITE	RESET VALUE	FUNCTION
D15	ADMUT	R/W	1	ADC Channel Mute 1 => ADC channel muted 0 => ADC channel not muted Note: If AGC is enabled, then D15–D8 reflects gain being applied by AGC. If AGC is on, the decoding for read values is as follows: 01110111 => +59.5 dB 01110110 => +59.0 dB ----- 00000000 => 0 dB ----- 11101001 => -11.5 dB 11101000 => -12 dB
D14–D8	ADPGA	R/W	0000000	ADC PGA Settings 0000000 => ADC PGA = 0 dB 0000001 => ADC PGA = 0.5 dB 0000010 => ADC PGA = 1.0 dB ----- 1110110 => ADC PGA = 59.0 dB 1110111 => ADC PGA = 59.5 dB 1111000 => ADC PGA = 59.5 dB ----- 1111110 => ADC PGA = 59.5 dB 1111111 => ADC PGA = 59.5 dB Note: If AGC is enabled, then D15–D8 reflects gain being applied by AGC. If AGC is on, the decoding for read values is as follows 01110111 => +59.5 dB 01110110 => +59.0 dB ----- 00000000 => 0 dB ----- 11101001 => -11.5 dB 11101000 => -12 dB
D7–D5	AGCTG	R/W	000	AGC Target Level. These three bits set the AGC's targeted ADC output level. 000 => -5.5 dB 001 => -8.0 dB 010 => -10 dB 011 => -12 dB 100 => -14 dB 101 => -17 dB 110 => -20 dB 111 => -24 dB

BIT	NAME	READ/ WRITE	RESET VALUE	FUNCTION																																		
D4–D1	AGCTC	R/W	0000	<p>AGC Time Constant. These four bits set the AGC attack and decay time constants. Time constants remain the same irrespective of any sampling frequency.</p> <table border="1"> <thead> <tr> <th>Attack Time (ms)</th> <th>Decay Time (ms)</th> </tr> </thead> <tbody> <tr><td>0000</td><td>8 100</td></tr> <tr><td>0001</td><td>11 100</td></tr> <tr><td>0010</td><td>16 100</td></tr> <tr><td>0011</td><td>20 100</td></tr> <tr><td>0100</td><td>8 200</td></tr> <tr><td>0101</td><td>11 200</td></tr> <tr><td>0110</td><td>16 200</td></tr> <tr><td>0111</td><td>20 200</td></tr> <tr><td>1000</td><td>8 400</td></tr> <tr><td>1001</td><td>11 400</td></tr> <tr><td>1010</td><td>16 400</td></tr> <tr><td>1011</td><td>20 400</td></tr> <tr><td>1100</td><td>8 500</td></tr> <tr><td>1101</td><td>11 500</td></tr> <tr><td>1110</td><td>16 500</td></tr> <tr><td>1111</td><td>20 500</td></tr> </tbody> </table>	Attack Time (ms)	Decay Time (ms)	0000	8 100	0001	11 100	0010	16 100	0011	20 100	0100	8 200	0101	11 200	0110	16 200	0111	20 200	1000	8 400	1001	11 400	1010	16 400	1011	20 400	1100	8 500	1101	11 500	1110	16 500	1111	20 500
Attack Time (ms)	Decay Time (ms)																																					
0000	8 100																																					
0001	11 100																																					
0010	16 100																																					
0011	20 100																																					
0100	8 200																																					
0101	11 200																																					
0110	16 200																																					
0111	20 200																																					
1000	8 400																																					
1001	11 400																																					
1010	16 400																																					
1011	20 400																																					
1100	8 500																																					
1101	11 500																																					
1110	16 500																																					
1111	20 500																																					
D0	AGCEN	R/W	0	<p>AGC Enable 0 => AGC is off (ADC PGA is controlled by D15–D8 ADC PGA Control) 1 => AGC is on (ADC PGA is controlled by AGC)</p>																																		

REGISTER 02H: CODEC DAC Gain Control

BIT	NAME	READ/ WRITE	RESET VALUE	FUNCTION
D15	DALMU	R/W	1	<p>DAC Left Channel Muted 1 => DAC left channel muted 0 => DAC left channel not muted</p>
D14–D8	DALVL	R/W	1111111	<p>DAC Left Channel Volume Control 0000000 => DAC left channel volume control = 0 dB 0000001 => DAC left channel volume control = –0.5 dB 0000010 => DAC left channel volume control = –1.0 dB ----- 1111110 => DAC left channel volume control = –63.0 dB 1111111 => DAC left channel volume control = –63.5 dB</p>
D7	DARMU	R/W	1	<p>DAC Right Channel Muted 1 => DAC right channel muted 0 => DAC right channel not muted</p>
D6–D0	DARVL	R/W	1111111	<p>DAC Right Channel Volume Control 0000000 => DAC right channel volume control = 0 dB 0000001 => DAC right channel volume control = –0.5 dB 0000010 => DAC right channel volume control = –1.0 dB ----- 1111110 => DAC right channel volume control = –63.0 dB 1111111 => DAC right channel volume control = –63.5 dB</p>

REGISTER 03H: CODEC Sidetone Control

BIT	NAME	READ/ WRITE	RESET VALUE	FUNCTION
D15	ASTMU	R/W	1	Analog Sidetone Mute Control 1 => Analog sidetone muted 0 => Analog sidetone not muted
D14–D8	ASTG	R/W	1000101	Analog Sidetone Gain Setting 0000000 => Analog sidetone gain setting = –34.5 dB 0000001 => Analog sidetone gain setting = –34 dB 0000010 => Analog sidetone gain setting = –33.5 dB ----- 1000101 => Analog sidetone gain setting = 0 dB 1000110 => Analog sidetone gain setting = 0.5 dB ----- 1011100 => Analog sidetone gain setting = 11.5 dB 1011101 => Analog sidetone gain setting = 12 dB 1011110 => Analog sidetone gain setting = 12 dB 1011111 => Analog sidetone gain setting = 12 dB ----- 11xxxxx => Analog sidetone gain setting = 12 dB
D7	DSTMU	R/W	1	Digital Sidetone Mute Control 1 => Digital sidetone muted 0 => Digital sidetone not muted
D6–D1	DSTG	R/W	000000	Digital Sidetone Setting 000000 => Digital sidetone gain = 0 dB 000001 => Digital sidetone gain = –1.5 dB 000010 => Digital sidetone gain = –3.0 dB ----- 1xxxxx => Digital sidetone gain = –48 dB Note: Digital sidetone setting applied at zero cross over
D0	ASTGF	R	0	Analog Sidetone PGA Flag (Read Only) 0 => Gain applied /= PGA register setting 1 => PGA applied = PGA register setting. Note: Analog sidetone gain is implemented at zero crossings of the signal.

REGISTER 04H: Audio Control 2

BIT	NAME	READ/ WRITE	RESET VALUE	FUNCTION
D15	KCLEN	R/W	0	Keyclick Enable 0 => Keyclick disabled 1 => Keyclick enabled Note: This bit is automatically cleared after giving out the keyclick signal length equal to the programmed value.
D14–D12	KCLAC	R/W	100	Keyclick Amplitude Control 000 => Lowest amplitude 100 => Medium amplitude 111 => Highest amplitude
D11	APGASS	R/W	0	ADC Channel PGA Soft-Stepping Control 0 => 0.5dB change every ADWS 1 => 0.5dB change every 2 ADWS Note: When AGC is enabled, this bit is read only. The read values indicate the following 0 => signal power greater than noise threshold 1 => signal power is less than noise threshold
D10–D8	KCLFRQ	R/W	100	Keyclick Frequency 000 => 62.5 Hz 001 => 125 Hz 010 => 250 Hz 011 => 500 Hz 100 => 1 kHz 101 => 2 kHz 110 => 4 kHz 111 => 8 kHz
D7–D4	KCLLN	R/W	0001	Keyclick Length 0000 => 2 periods key click 0001 => 4 periods key click 0010 => 6 periods key click ----- 1110 => 30 periods key click 1111 => 32 periods key click
D3	DLGAF	R	0	DAC Left Channel PGA Flag (Read Only) 0 => Gain applied != PGA register setting 1 => Gain applied = PGA register setting Note: This flag indicates when the soft-stepping for DAC left channel is completed
D2	DRGAF	R	0	DAC Right Channel PGA Flag (Read Only) 0 => Gain applied != PGA register setting 1 => Gain applied = PGA register setting Note: This flag indicates when the soft-stepping for DAC right channel is completed
D1	DASTC	R/W	0	DAC Channel PGA Soft-Stepping Control 0 => 0.5dB change every LRCK 1 => 0.5dB change every 2 LRCK
D0	ADGAF	R	0	ADC Channel PGA Flag (Read Only) 1 => Gain applied = PGA register setting 0 => Gain applied != PGA register setting Note: This flag indicates when the soft-stepping for ADC channel is completed. When AGC is enabled the read value of this bit indicates the following: 0 => AGC is not saturated. 1 => AGC is saturated.

REGISTER 05H: CODEC Power Control

BIT	NAME	READ/ WRITE	RESET VALUE	FUNCTION
D15	PWDNC	R/W	1	Codec Power-Down Control 0 => Codec powered up 1 => Codec powered down
D14		R	0	Reserved (During read the value of this bit is 0. Write only 0 into this location.)
D13	ASTPWD	R/W	1	Analog Sidetone Power-down Control 0 => Analog sidetone powered up 1 => Analog sidetone powered down
D12	DAODRC	R/W	0	Audio Output Driver Control 0 => Output driver in low power mode 1 => Output driver in high power mode
D11	ASTPWF	R	1	Analog Sidetone Power-Down Flag 0 => Analog sidetone powered down is not complete. 1 => Analog sidetone powered down is complete.
D10	DAPWDN	R/W	1	DAC Power-Down Control 0 => Power up the DAC 1 => Power down the DAC
D9	ADPWDN	R/W	1	ADC Power-Down Control 0 => Power up the ADC 1 => Power down the ADC
D8	VGPWDN	R/W	1	Driver Virtual Ground Power Down 0 => Power up the VGND amp 1 => Power down the VGND amp
D7	ADPWDF	R	1	ADC Power-Down Flag 0 => ADC power down is not complete. 1 => ADC power down is complete.
D6	DAPWDF	R	1	DAC Power-Down Flag (See DAC Power down section of this data sheet) 0 => DAC power down is not complete. 1 => DAC power down is complete.
D5	ADWSF	R/W	0	ADWS Pin Function 0 => ADWS pin acts as hardware power down. 1 => ADWS pin acts as ADC Word–Select. Note: ADWS pin should be programmed as hardware power down only if the ADC channel is powered down or both the ADC and DAC channels have the same sampling rate. If both the ADC and DAC channels have the same sampling rates, then LRCK can act as a common word select signal for the ADC and DAC.
D4	VBIAS	R/W	0	VBIAS Voltage 0 => VBIAS output = 2.5 V 1 => VBIAS output = 2.0 V
D3–D2		R	00	Reserved. Write only 00 into this location.
D1	EFFCTL	R/W	0	Digital Audio Effects Filter Control 0 => Disable digital audio effects filter 1 => Enable digital audio effects filter
D0	DEEMPF	R/W	0	De–Emphasis Filter Enable 0 => Disable de-emphasis filter 1 => Enable de-emphasis filter

REGISTER 06H: Audio Control 3

BIT	NAME	READ/ WRITE	RESET VALUE	FUNCTION
D15–D14	DMSVOL	R/W	00	DAC Channel Master Volume Control 00 => Left channel and right channel have independent volume controls 01 => Left channel volume control is the programmed value of the right channel volume control. 10 => Right channel volume control is the programmed value of the left channel volume control. 11 => same as 00
D13	REFFS	R/W	0	Reference Sampling Rate. This setting controls the coefficients in the de-emphasis filter, the time-constants in AGC, and internal divider values that generate a clock for the measurement ADC. If an Fsref above 48 kHz is being used, then it is recommended to set this to the 48-kHz setting, otherwise either setting can be used. 0 => Fsref = 48.0 kHz 1 => Fsref = 44.1 kHz
D12	DAXFM	R/W	0	Master Transfer Mode 0 => Continuous data transfer mode 1 => 256-s data transfer mode
D11	SLVMS	R/W	0	Codec Master Slave Selection 0 => 'AIC26 is slave codec 1 => 'AIC26 is master codec
D10–D9	DAPK2PK	R/W	00	DAC Max Output Signal Swing and Common Mode Voltage 00 => DAC max output signal swing = 2.0 V, V _{CM} = 1.35 V 01 => DAC max output signal swing = 2.192 V (only recommended for analog supply of 3.0 V and digital supply of 1.65 V and above), V _{CM} = 1.48 V 10 => DAC max output signal swing = 2.402 V (only recommended for analog supply of 3.3 V and digital supply of 1.8 V and above), V _{CM} = 1.62 V 11 => DAC max output signal swing = 2.633 V (only recommended for analog supply of 3.6 V and digital supply of 1.95 V), V _{CM} = 1.78 V
D8	ADCOVF	R	0	ADC Channel Overflow Flag (Read Only) 0 => ADC channel data is within saturation limits. 1 => ADC channel data has exceeded saturation limits. Note : This flag is reset only on register read.
D7	DALOVF	R	0	DAC Left Channel Overflow Flag (Read Only) 0 => DAC left channel data is within saturation limits. 1 => DAC left channel data has exceeded saturation limits. Note : This flag is reset only on register read.
D6	DAROVF	R	0	DAC Right Channel Overflow Flag (Read Only) 0 => DAC right channel data is within saturation limits. 1 => DAC right channel data has exceeded saturation limits. Note : This flag is reset only on register read.
D5–D4	AGCNL	R/W	00	AGC Noise Threshold. 00 => –60 dB 01 => –70 dB 10 => –80 dB 11 => –90 dB Note: AGC does not try to achieve the programmed ADC output levels if the input signal is below the programmed noise thresholds. This feature helps to avoid amplifying noise during silence periods.
D3	CLPST	R/W	0	AGC Clip Stepping Enable 0 => Not enabled 1 => Enabled
D2–D0	REVID	R	XXX	Reserved

REGISTER 07H: Digital Audio Effects Filter Coefficients

BIT	NAME	READ/ WRITE	RESET VALUE (IN DECIMAL)	FUNCTION
D15–D0	L_N0	R/W	27619	Left channel digital audio effects filter coefficient N0

REGISTER 08H: Digital Audio Effects Filter Coefficients

BIT	NAME	READ/ WRITE	RESET VALUE (IN DECIMAL)	FUNCTION
D15–D0	L_N1	R/W	–27034	Left channel digital audio effects filter coefficient N1

REGISTER 09H: Digital Audio Effects Filter Coefficients

BIT	NAME	READ/ WRITE	RESET VALUE (IN DECIMAL)	FUNCTION
D15–D0	L_N2	R/W	26461	Left channel digital audio effects filter coefficient N2

REGISTER 0AH: Digital Audio Effects Filter Coefficients

BIT	NAME	READ/ WRITE	RESET VALUE (IN DECIMAL)	FUNCTION
D15–D0	L_N3	R/W	27619	Left channel digital audio effects filter coefficient N3

REGISTER 0BH: Digital Audio Effects Filter Coefficients

BIT	NAME	READ/ WRITE	RESET VALUE (IN DECIMAL)	FUNCTION
D15–D0	L_N4	R/W	–27034	Left channel digital audio effects filter coefficient N4

REGISTER 0CH: Digital Audio Effects Filter Coefficients

BIT	NAME	READ/ WRITE	RESET VALUE (IN DECIMAL)	FUNCTION
D15–D0	L_N5	R/W	26461	Left channel digital audio effects filter coefficient N5

REGISTER 0DH: Digital Audio Effects Filter Coefficients

BIT	NAME	READ/ WRITE	RESET VALUE (IN DECIMAL)	FUNCTION
D15–D0	L_D1	R/W	32131	Left channel digital audio effects filter coefficient D1

REGISTER 0EH: Digital Audio Effects Filter Coefficients

BIT	NAME	READ/ WRITE	RESET VALUE (IN DECIMAL)	FUNCTION
D15–D0	L_D2	R/W	–31506	Left channel digital audio effects filter coefficient D2

REGISTER 0FH: Digital Audio Effects Filter Coefficients

BIT	NAME	READ/ WRITE	RESET VALUE (IN DECIMAL)	FUNCTION
D15–D0	L_D4	R/W	32131	Left channel digital audio effects filter coefficient D4

REGISTER 10H: Digital Audio Effects Filter Coefficients

BIT	NAME	READ/ WRITE	RESET VALUE (IN DECIMAL)	FUNCTION
D15–D0	L_D5	R/W	–31506	Left channel digital audio effects filter coefficient D5

REGISTER 11H: Digital Audio Effects Filter Coefficients

BIT	NAME	READ/ WRITE	RESET VALUE (IN DECIMAL)	FUNCTION
D15–D0	R_N0	R/W	27619	Right channel digital audio effects filter coefficient N0

REGISTER 12H: Digital Audio Effects Filter Coefficients

BIT	NAME	READ/ WRITE	RESET VALUE (IN DECIMAL)	FUNCTION
D15–D0	R_N1	R/W	–27034	Right channel digital audio effects filter coefficient N1

REGISTER 13H: Digital Audio Effects Filter Coefficients

BIT	NAME	READ/ WRITE	RESET VALUE (IN DECIMAL)	FUNCTION
D15–D0	R_N2	R/W	26461	Right channel digital audio effects filter coefficient N2

REGISTER 14H: Digital Audio Effects Filter Coefficients

BIT	NAME	READ/ WRITE	RESET VALUE (IN DECIMAL)	FUNCTION
D15–D0	R_N3	R/W	27619	Right channel digital audio effects filter coefficient N3

REGISTER 15H: Digital Audio Effects Filter Coefficients

BIT	NAME	READ/ WRITE	RESET VALUE (IN DECIMAL)	FUNCTION
D15–D0	R_N4	R/W	–27034	Right channel digital audio effects filter coefficient N4

REGISTER 16H: Digital Audio Effects Filter Coefficients

BIT	NAME	READ/ WRITE	RESET VALUE (IN DECIMAL)	FUNCTION
D15–D0	R_N5	R/W	26461	Right channel digital audio effects filter coefficient N5

REGISTER 17H: Digital Audio Effects Filter Coefficients

BIT	NAME	READ/ WRITE	RESET VALUE (IN DECIMAL)	FUNCTION
D15–D0	R_D1	R/W	32131	Right channel digital audio effects filter coefficient D1

REGISTER 18H: Digital Audio Effects Filter Coefficients

BIT	NAME	READ/ WRITE	RESET VALUE (IN DECIMAL)	FUNCTION
D15–D0	R_D2	R/W	–31506	Right channel digital audio effects filter coefficient D2

REGISTER 19H: Digital Audio Effects Filter Coefficients

BIT	NAME	READ/ WRITE	RESET VALUE (IN DECIMAL)	FUNCTION
D15–D0	R_D4	R/W	32131	Right channel digital audio effects filter coefficient D4

REGISTER 1AH: Digital Audio Effects Filter Coefficients

BIT	NAME	READ/ WRITE	RESET VALUE (IN DECIMAL)	FUNCTION
D15–D0	R_D5	R/W	–31506	Right channel digital audio effects filter coefficient D5

REGISTER 1BH: PLL Programmability

BIT	NAME	READ/ WRITE	RESET VALUE	FUNCTION
D15	PLLSEL	R/W	0	PLL Enable 0 => Disable PLL 1 => Enable PLL
D14–D11	QVAL	R/W	0010	Q value. Valid only if PLL is disabled. 0000 => 16 0001 => 17 0010 => 2 0011 => 3 ----- 1100 => 12 1101 => 13 1110 => 14 1111 => 15
D10–D8	PVAL	R/W	000	P value. Valid when PLL is enabled 000 => 8 001 => 1 010 => 2 011 => 3 100 => 4 101 => 5 110 => 6 111 => 7
D7–D2	JVAL	R/W	000001	J value. Valid only if PLL is enabled. 000000 => Not valid 000001 => 1 000010 => 2 ----- 111110 => 62 111111 => 63
D1–D0	Reserved	R	00	Reserved (write only 00)

REGISTER 1CH: PLL Programmability

BIT	NAME	READ/ WRITE	RESET VALUE	FUNCTION
D15–D2	DVAL	R/W	0 (in decimal)	D value. Used when PLL is enabled. D value is valid from 0000 to 9999 in decimal. Programmed value greater than 9999 is treated as 9999. 00000000000000 => 0 decimal 00000000000001 => 1 decimal
D1–D0	Reserved	R	00	Reserved (write only 00)

REGISTER 1DH: Audio Control 4

BIT	NAME	READ/ WRITE	RESET VALUE	FUNCTION
D15	ASTPD	R/W	0	ADC PGA Soft-Stepping Control 0 => Soft-stepping enabled 1 => Soft-stepping disabled
D14	DASTPD	R/W	0	DAC PGA Soft-Stepping Control 0 => Soft-stepping enabled 1 => Soft-stepping disabled
D13	ASSTPD	R/W	0	Analog Sidetone Soft-Stepping Control 0 => Soft-stepping enabled 1 => Soft-stepping disabled
D12	DSTPD	R/W	0	Digital Sidetone Zero Cross Control 0 => Zero cross enabled 1 => Zero cross disabled
D11	Reserved	R	0	Reserved
D10–D9	AGC_HYST	R/W	00	AGC Hysteresis Control 00 => 1-dB hysteresis 01 => 2-dB hysteresis 10 => 4-dB hysteresis 11 => No hysteresis
D8	SHCKT_DIS	R/W	0	Disable Short Circuit Detection 0 => Short circuit detection enabled 1 => Short circuit detection disabled
D7	SHCKT_PD	R/W	0	Power Down Drivers if Short Circuit Detected 0 => No auto power down of drivers on short circuit. 1 => Auto power down drivers on short circuit.
D6	SHCKT_FLAG	R	0	Short Circuit Detected Flag 0 => Short circuit not detected 1 => Short circuit detected
D5	DAC_POP_RED	R	0	DAC POP Reduction Enable 0 => Disable POP reduction 1 => Enable POP reduction
D4	DAC_POP_RED_ SET1	R/W	0	DAC POP Reduction Setting 1 0 => Fast setting 1 => Slow setting
D3–D2	DAC_POP_RED_ SET2	R/W	00	DAC POP Reduction Setting 2 00 => Long setting 11 => Short setting
D1–D0	PGID	R	XX	

REGISTER 1EH: Audio Control 5

BIT	NAME	READ/ WRITE	RESET VALUE	FUNCTION
D15–D9	MAX_AGC_PGA	R/W	1111111	MAX Input Gain Applicable for AGC 0000000 => 0 dB 0000001 => 0.5 dB 0000010 => 1.0 dB ----- 1110110 => 59.0 dB 1110111 => 59.5 dB 1111000 => 59.5 dB ----- 1111111 => 59.5 dB
D8–D6	AGC_NOI_DEB	R/W	000	AGC Debounce Time for Speech Mode to Silence Mode Transition 000 => 0 ms 001 => 0.5 ms 010 => 1.0 ms ----- 110 => 16.0 ms 111 => 32.0 ms
D5–D3	AGC_SIG_DEB	R/W	000	AGC Debounce Time for Silence Mode to Speech Mode Transition 000 => 0 ms 001 => 0.5 ms 010 => 1.0 ms ----- 110 => 16.0 ms 111 => 32.0 ms
D2	DRV_POP_DIS	R/W	0	Audio Output Driver POP Reduction Enable 0 => Enabled 1 => Disabled
D1	DRV_POP_LEN	R/W	0	Audio Output Driver POP Reduction Duration 0 => Output driver ramps to final voltage in approximately 0.8 sec, if VGND is powered down (1 msec otherwise). 1 => Output driver ramps to final voltage in approximately 4 sec, if VGND is powered down (1 msec otherwise).
D0	Reserved	R	0	Reserved. Do not write 1 to this location.

LAYOUT

The following layout suggestions should provide optimum performance from the 'AIC26. However, many portable applications have conflicting requirements concerning power, cost, size, and weight. In general, most portable devices have fairly *clean* power and grounds because most of the internal components are very low power. This situation means less bypassing for the converter power and less concern regarding grounding. Still, each situation is unique and the following suggestions should be reviewed carefully.

For optimum performance, care must be taken with the physical layout of the 'AIC26 circuitry. The SAR architecture of the auxiliary converter is sensitive to glitches or sudden changes on the power supply, reference, ground connections, and digital inputs that occur just prior to latching the output of the analog comparator. Therefore, during any single conversion for an *n-bit* SAR converter, there are *n windows* in which large external transient voltages can easily affect the conversion result. Such glitches might originate from switching power supplies, nearby digital logic, and high power devices. The degree of error in the digital output depends on the reference voltage, layout, and the exact timing of the external event. The error can change if the external event changes in time with respect to the timing of the critical *n windows*.

With this in mind, power to the 'AIC26 must be clean and well bypassed. A 0.1- μ F ceramic bypass capacitor must be placed as close to the device as possible. A 1- μ F to 10- μ F capacitor may also be needed if the impedance between the 'AIC26 supply pins and the system power supply is high.

A bypass capacitor on the VREF pin is generally not needed because the reference is buffered by an internal op amp, although it can be useful to reduce reference noise level. If an external reference voltage originates from an op amp, make sure that it can drive any bypass capacitor that is used without oscillation.

The 'AIC26 architecture offers no inherent rejection of noise or voltage variation in regards to using an external reference input. This is of particular concern when the reference input is tied to the power supply. Any noise and ripple from the supply appears directly in the digital results. While high frequency noise can be filtered out, voltage variation due to line frequency (50 Hz or 60 Hz) can be difficult to remove.

The ground pins must be connected to a clean ground point. In many cases, this is the *analog* ground. Avoid connections which are too near the grounding point of a microcontroller or digital signal processor. If needed, run a ground trace directly from the converter to the power supply entry or battery connection point. The ideal layout includes an analog ground plane dedicated to the converter and associated analog circuitry.

CONVERSION TIME CALCULATION FOR THE 'AIC26

Auxiliary Measurement Operation

The time needed to make temperature, auxiliary, or battery measurements is given by:

$$t = \left\{ N_{AVG} \left[\left(N_{BITS} + 1 \right) \times \frac{8 \text{ MHz}}{f_{conv}} + n_1 + n_2 \right] + 1 \right\} \times t_{OSC} + 15 \times t_{OSC} + n_3 \times t_{OSC}$$

where:

$n_1 = 6$; if $f_{conv} = 8 \text{ MHz}$

7 ; if $f_{conv} \neq 8 \text{ MHz}$

$n_2 = 24$; if measurement is for TEMP1 case

12 ; if measurement is for other than TEMP1 case

$n_3 = 0$; if external reference mode is selected

3 ; if $t_{REF} = 0 \mu\text{s}$ or reference is programmed for power up all the time.

1 + $t_{REF} / 125 \text{ ns}$; if $t_{REF} \neq 0 \mu\text{s}$ and reference needs to power down between conversions.

t_{REF} is the reference power up delay time.

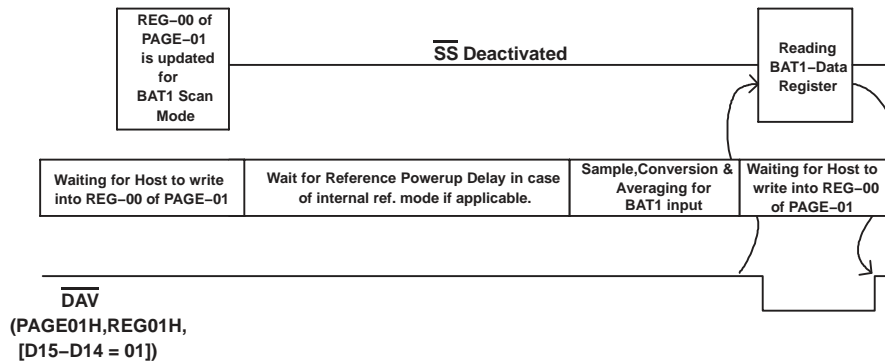

The time needed for continuous AUX conversion in scan mode is given by:

$$t = \left\{ N_{AVG} \left[\left(N_{BITS} + 1 \right) \times \frac{8 \text{ MHz}}{f_{conv}} + n_1 + 12 \right] + 1 \right\} \times t_{OSC} + 8 \times t_{OSC}$$

where:

$n_1 = 6$; if $f_{conv} = 8 \text{ MHz}$

7 ; if $f_{conv} \neq 8 \text{ MHz}$

NOTE: The above equation is valid only from second conversion onwards.

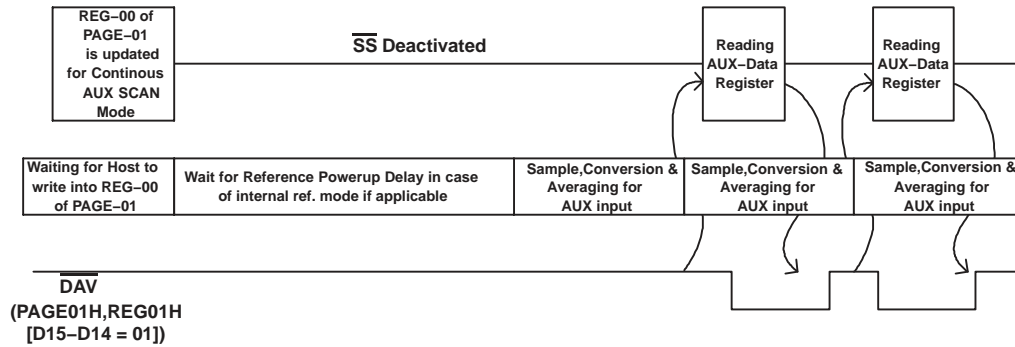

Port Scan Operation

The time needed to complete one set of port scan conversions is given by:

$$t = 3 \times \left\{ N_{AVG} \left[\left(N_{BITS} + 1 \right) \times \frac{8 \text{ MHz}}{f_{conv}} + n_1 + 12 \right] + 1 \right\} \times t_{OSC} + 31 \times t_{OSC} + n_2 \times t_{OSC}$$

where:

$n_1 = 6$; if $f_{conv} = 8 \text{ MHz}$

7 ; if $f_{conv} \neq 8 \text{ MHz}$

$n_2 = 0$; if external reference mode is selected

3 ; if $t_{REF} = 0 \mu\text{s}$ or reference is programmed for power up all the times.

1 + $t_{REF}/125 \text{ ns}$; if $t_{REF} \neq 0 \mu\text{s}$ and reference needs to power down between conversions.

t_{REF} is the reference power up delay time.

AUDIO CODEC FILTER FREQUENCY RESPONSES

Pass-Band Frequency Response of ADC Digital Filter

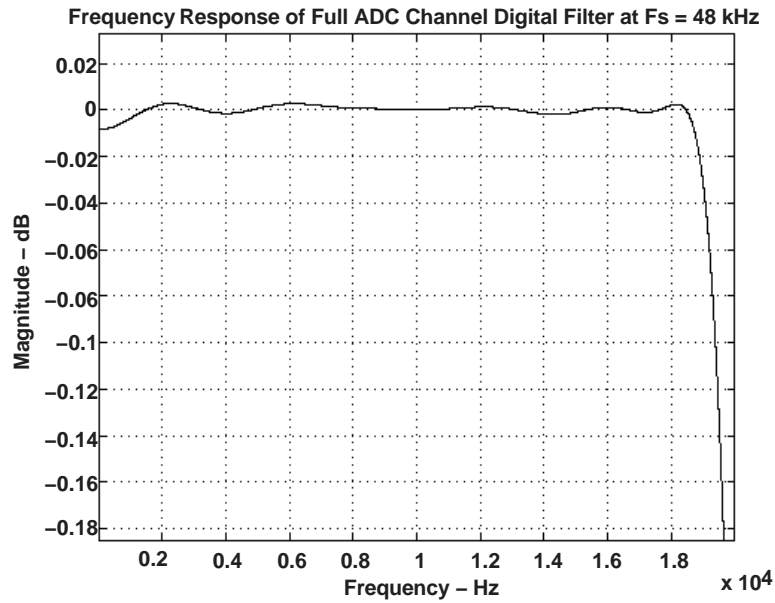

Frequency Response of ADC High-Pass Filter ($F_{cut-off} = 0.0045 F_s$)

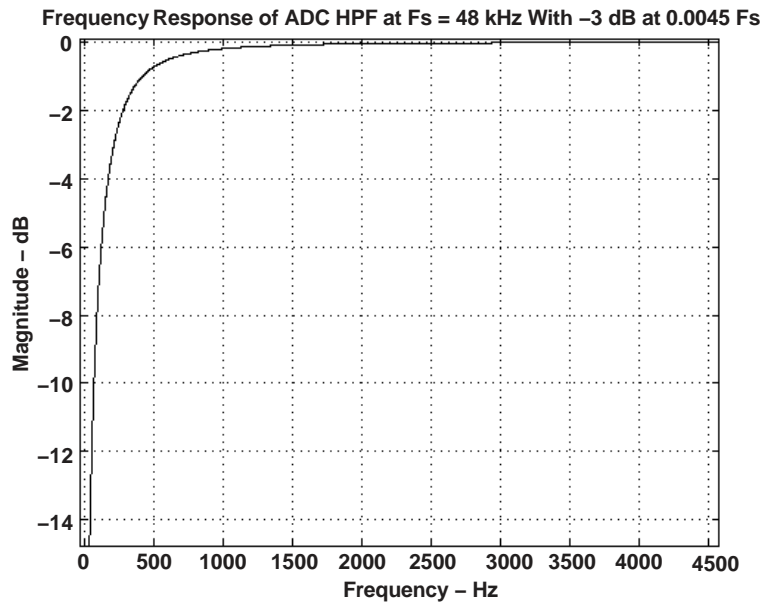

Frequency Response of ADC High-Pass Filter (Fcut-off = 0.0125 Fs)

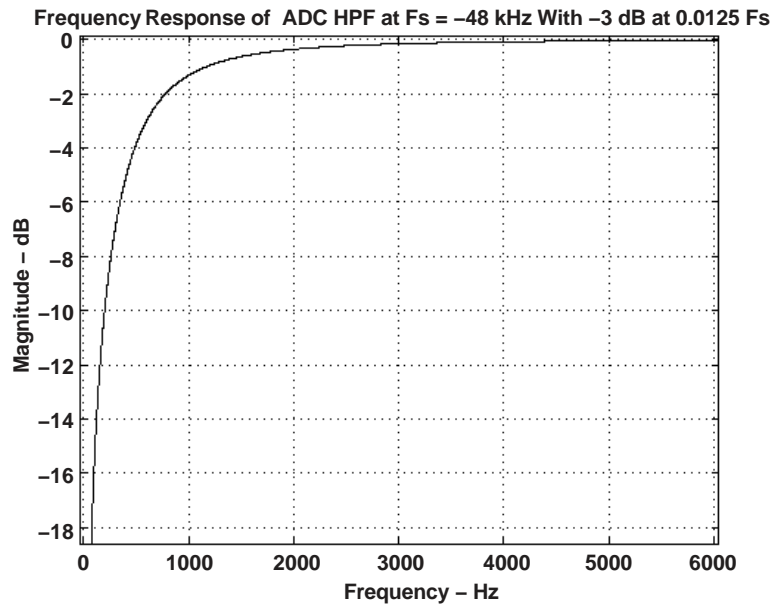

Frequency Response of ADC High-Pass Filter (Fcut-off = 0.025 Fs)

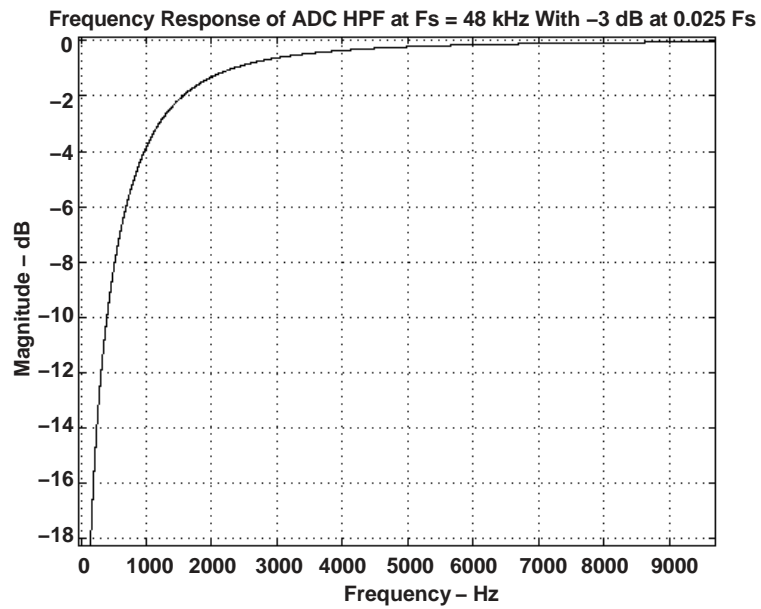

DAC CHANNEL DIGITAL FILTER

DAC Channel Digital Filter Frequency Response

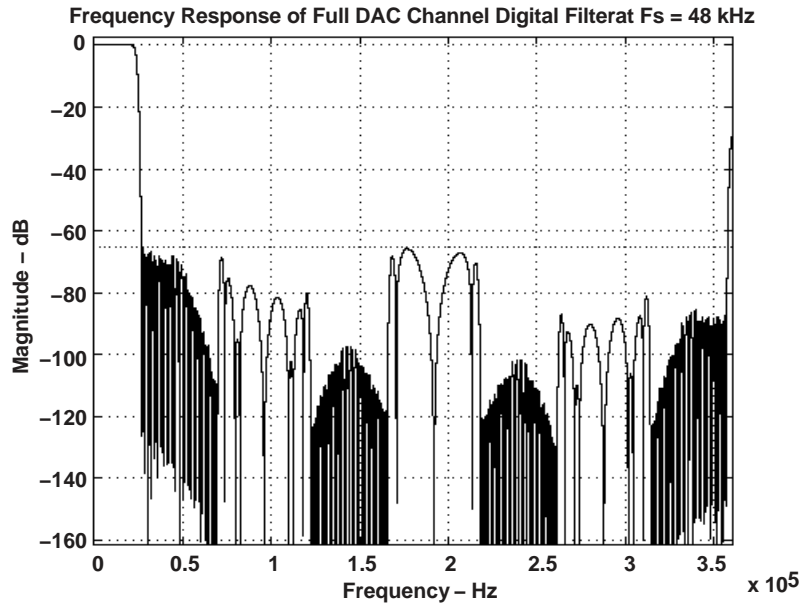

DAC Channel Digital Filter Pass-Band Frequency Response

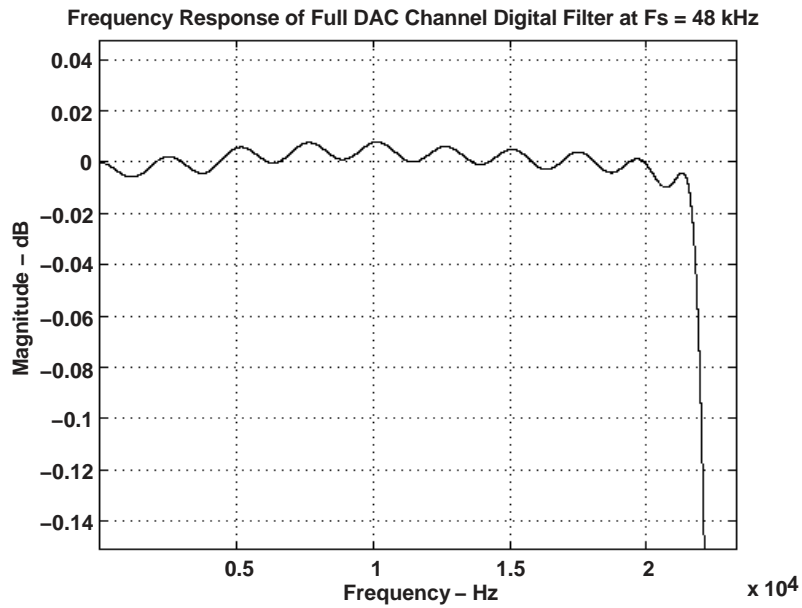

DEFAULT DIGITAL AUDIO EFFECTS FILTER RESPONSE AT 48 kbps

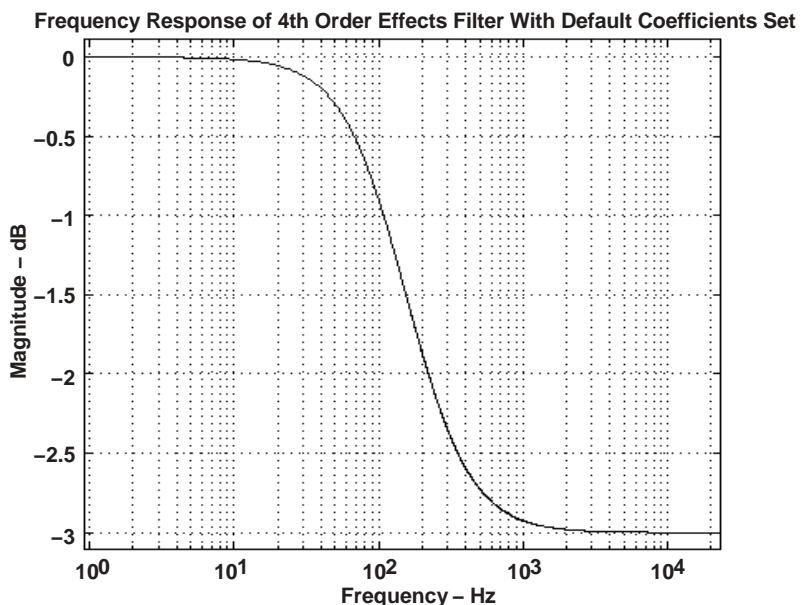

DE-EMPHASIS FILTER FREQUENCY RESPONSE

De-Emphasis Filter Response at 32 kbps

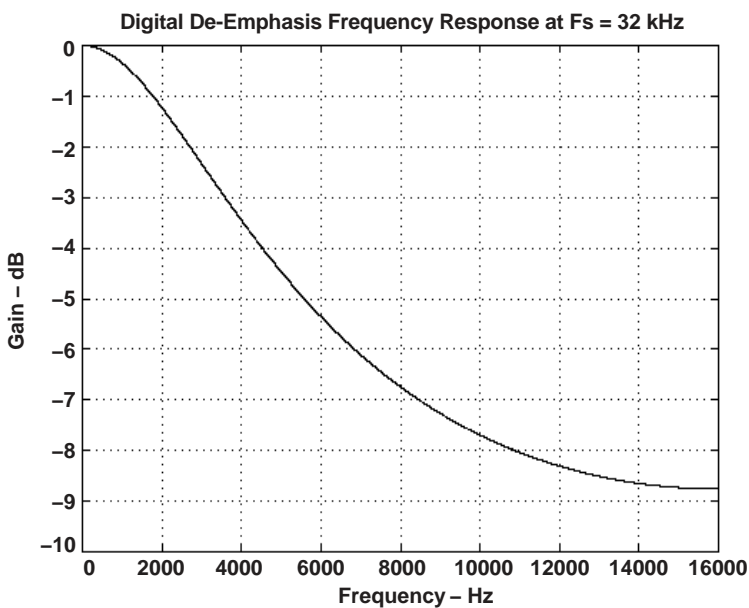

De-Emphasis Error at 32 kbps

De-Emphasis Error With Respect to Ideal Frequency Response For $F_s = 33 \text{ kHz}$

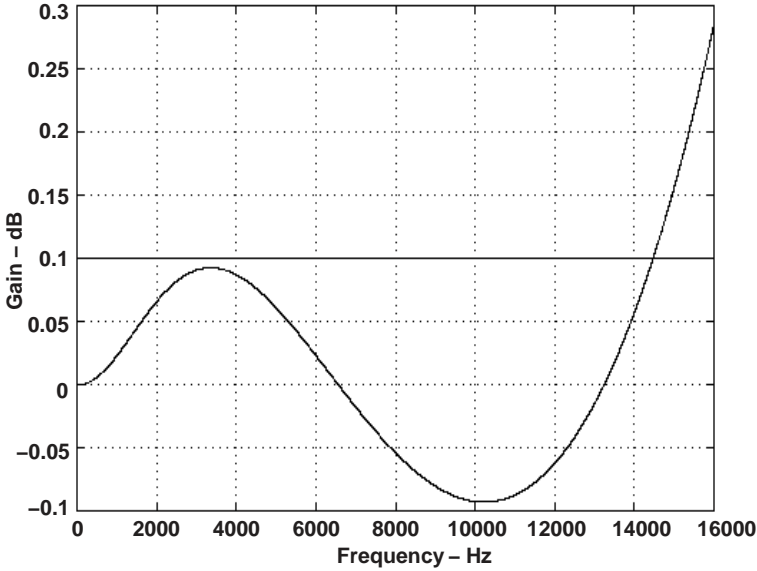

De-Emphasis Filter Frequency Response at 44.1 kbps

Digital De-Emphasis Frequency Response For $F_s = 44.1 \text{ kHz}$

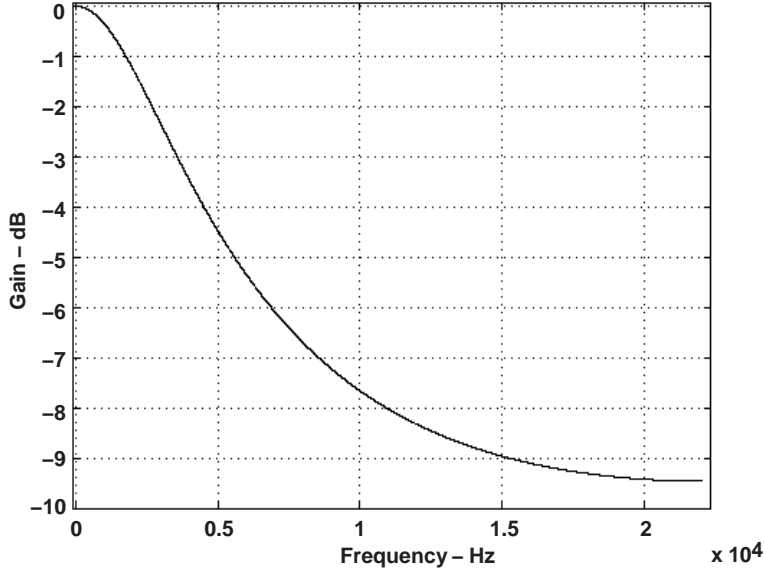

De-Emphasis Error at 44.1 kps

De-Emphasis Error With Respect to Ideal Frequency Response For $F_s = 44.1$ kHz

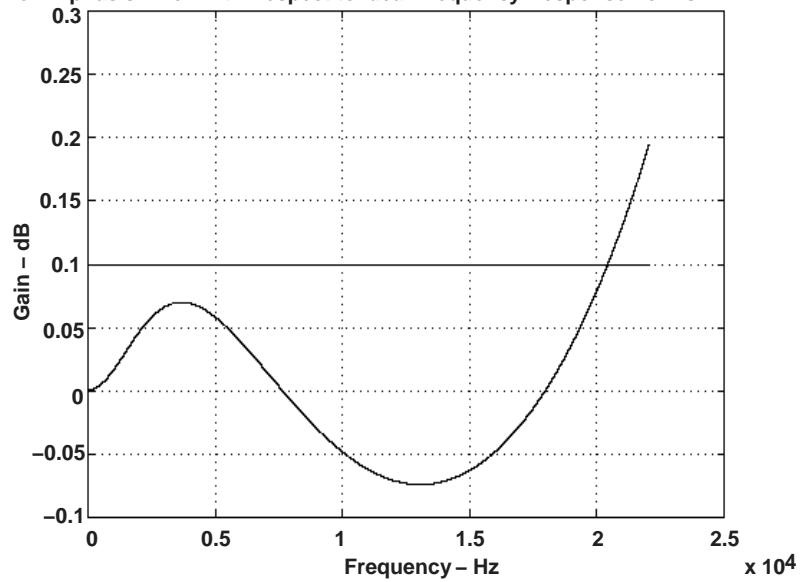

De-Emphasis Frequency Response at 48 kps

Digital De-Emphasis Frequency Response at $F_s = 48$ kHz

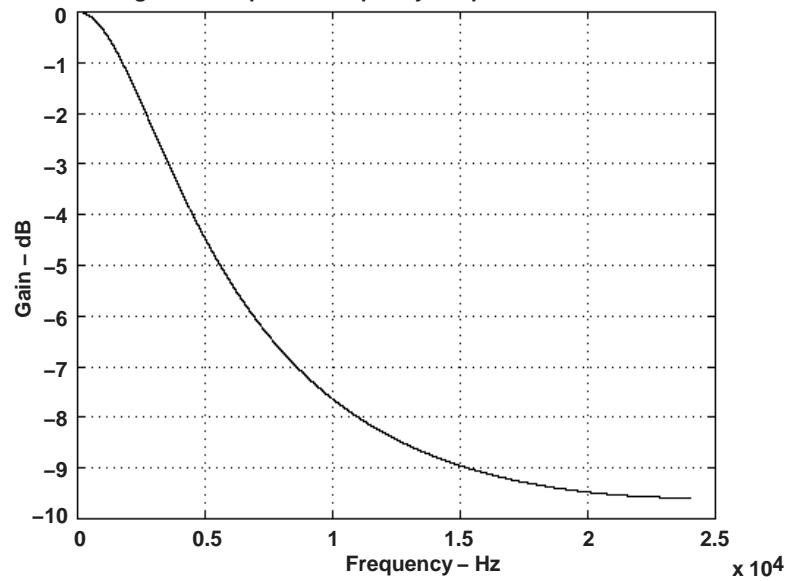

De-Emphasis Error at 48 ksp/s

De-Emphasis Error With Respect to Ideal Frequency Response For $F_s = 48 \text{ kHz}$

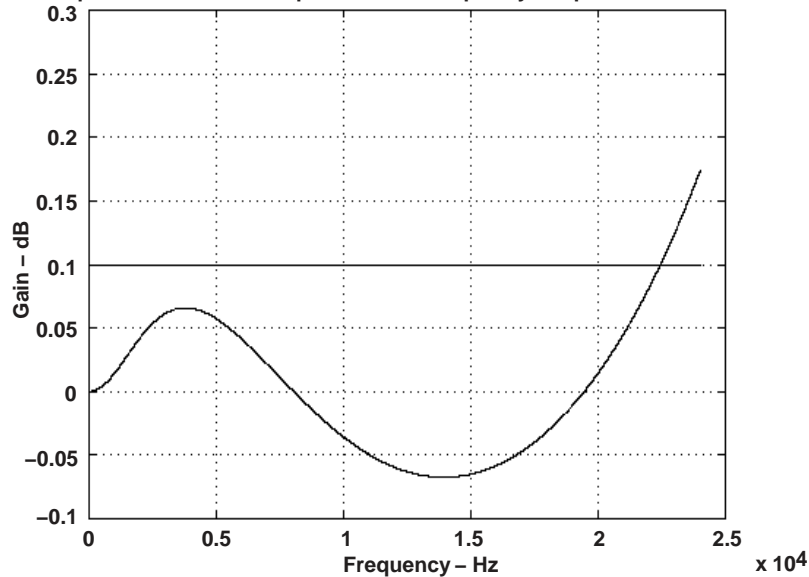

PLL PROGRAMMING

The on-chip PLL in the 'AIC26 can be used to generate sampling clocks from a wide range of MCLK's available in a system. The PLL works by generating oversampled clocks with respect to F_{sref} (44.1 kHz or 48 kHz). Frequency division generates all other internal clocks. The table below gives a sample programming for PLL registers for some standard MCLK's when PLL is required. Whenever the MCLK is of the form of $N \times 128 \times F_{sref}$ ($N=2,3,\dots,17$), PLL is not required.

$F_{sref} = 44.1 \text{ kHz}$

MCLK (MHz)	P	J	D	ACHIEVED FSREF	% ERROR
2.8224	1	32	0	44100.00	0.0000
5.6448	1	16	0	44100.00	0.0000
12	1	7	5264	44100.00	0.0000
13	1	6	9474	44099.71	0.0007
16	1	5	6448	44100.00	0.0000
19.2	1	4	7040	44100.00	0.0000
19.68	1	4	5893	44100.30	-0.0007
48	4	7	5264	44100.00	0.0000

$F_{sref} = 48 \text{ kHz}$

MCLK (MHz)	P	J	D	ACHIEVED FSREF	% ERROR
2.048	1	48	0	48000.00	0.0000
3.072	1	32	0	48000.00	0.0000
4.096	1	24	0	48000.00	0.0000
6.144	1	16	0	48000.00	0.0000
8.192	1	12	0	48000.00	0.0000
12	1	8	1920	48000.00	0.0000
13	1	7	5618	47999.71	0.0006
16	1	6	1440	48000.00	0.0000
19.2	1	5	1200	48000.00	0.0000
19.68	1	4	9951	47999.79	0.0004
48	4	8	1920	48000.00	0.0000

PACKAGING INFORMATION

Orderable Device	Status (1)	Package Type	Package Drawing	Pins	Package Qty	Eco Plan (2)	Lead finish/ Ball material (6)	MSL Peak Temp (3)	Op Temp (°C)	Device Marking (4/5)	Samples
TLV320AIC261RHB	ACTIVE	VQFN	RHB	32	73	RoHS & Green	NIPDAU	Level-2-260C-1 YEAR	-40 to 85	AIC26I	Samples
TLV320AIC261RHBR	ACTIVE	VQFN	RHB	32	3000	RoHS & Green	NIPDAU	Level-2-260C-1 YEAR	-40 to 85	AIC26I	Samples
TLV320AIC261RHBRG4	ACTIVE	VQFN	RHB	32	3000	RoHS & Green	NIPDAU	Level-2-260C-1 YEAR	-40 to 85	AIC26I	Samples

(1) The marketing status values are defined as follows:

ACTIVE: Product device recommended for new designs.

LIFEBUY: TI has announced that the device will be discontinued, and a lifetime-buy period is in effect.

NRND: Not recommended for new designs. Device is in production to support existing customers, but TI does not recommend using this part in a new design.

PREVIEW: Device has been announced but is not in production. Samples may or may not be available.

OBSOLETE: TI has discontinued the production of the device.

(2) **RoHS:** TI defines "RoHS" to mean semiconductor products that are compliant with the current EU RoHS requirements for all 10 RoHS substances, including the requirement that RoHS substance do not exceed 0.1% by weight in homogeneous materials. Where designed to be soldered at high temperatures, "RoHS" products are suitable for use in specified lead-free processes. TI may reference these types of products as "Pb-Free".

RoHS Exempt: TI defines "RoHS Exempt" to mean products that contain lead but are compliant with EU RoHS pursuant to a specific EU RoHS exemption.

Green: TI defines "Green" to mean the content of Chlorine (Cl) and Bromine (Br) based flame retardants meet JS709B low halogen requirements of <=1000ppm threshold. Antimony trioxide based flame retardants must also meet the <=1000ppm threshold requirement.

(3) MSL, Peak Temp. - The Moisture Sensitivity Level rating according to the JEDEC industry standard classifications, and peak solder temperature.

(4) There may be additional marking, which relates to the logo, the lot trace code information, or the environmental category on the device.

(5) Multiple Device Markings will be inside parentheses. Only one Device Marking contained in parentheses and separated by a "~" will appear on a device. If a line is indented then it is a continuation of the previous line and the two combined represent the entire Device Marking for that device.

(6) Lead finish/Ball material - Orderable Devices may have multiple material finish options. Finish options are separated by a vertical ruled line. Lead finish/Ball material values may wrap to two lines if the finish value exceeds the maximum column width.

Important Information and Disclaimer:The information provided on this page represents TI's knowledge and belief as of the date that it is provided. TI bases its knowledge and belief on information provided by third parties, and makes no representation or warranty as to the accuracy of such information. Efforts are underway to better integrate information from third parties. TI has taken and continues to take reasonable steps to provide representative and accurate information but may not have conducted destructive testing or chemical analysis on incoming materials and chemicals. TI and TI suppliers consider certain information to be proprietary, and thus CAS numbers and other limited information may not be available for release.

In no event shall TI's liability arising out of such information exceed the total purchase price of the TI part(s) at issue in this document sold by TI to Customer on an annual basis.

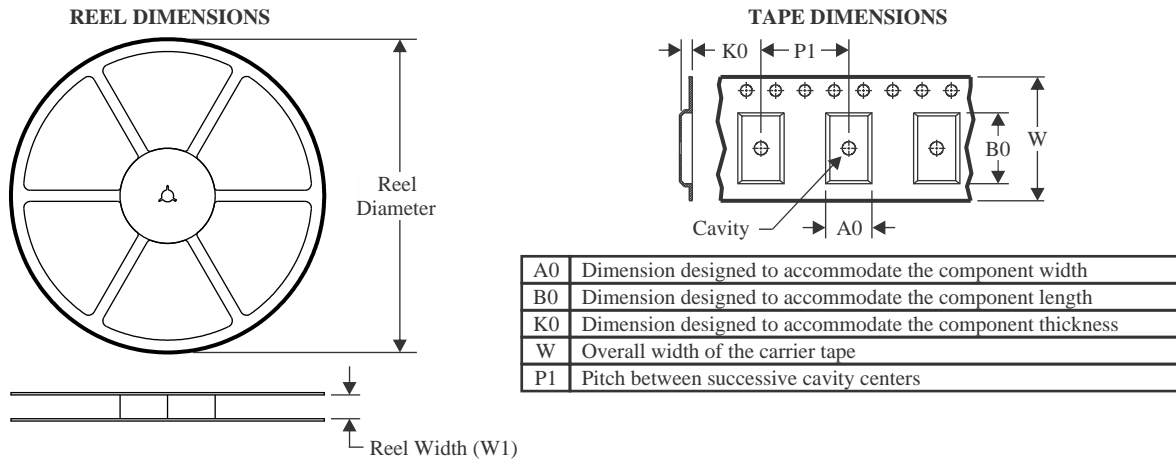
TAPE AND REEL INFORMATION

QUADRANT ASSIGNMENTS FOR PIN 1 ORIENTATION IN TAPE



*All dimensions are nominal

Device	Package Type	Package Drawing	Pins	SPQ	Reel Diameter (mm)	Reel Width W1 (mm)	A0 (mm)	B0 (mm)	K0 (mm)	P1 (mm)	W (mm)	Pin1 Quadrant
TLV320AIC261RHBR	VQFN	RHB	32	3000	330.0	12.4	5.3	5.3	1.5	8.0	12.0	Q2

TAPE AND REEL BOX DIMENSIONS

*All dimensions are nominal

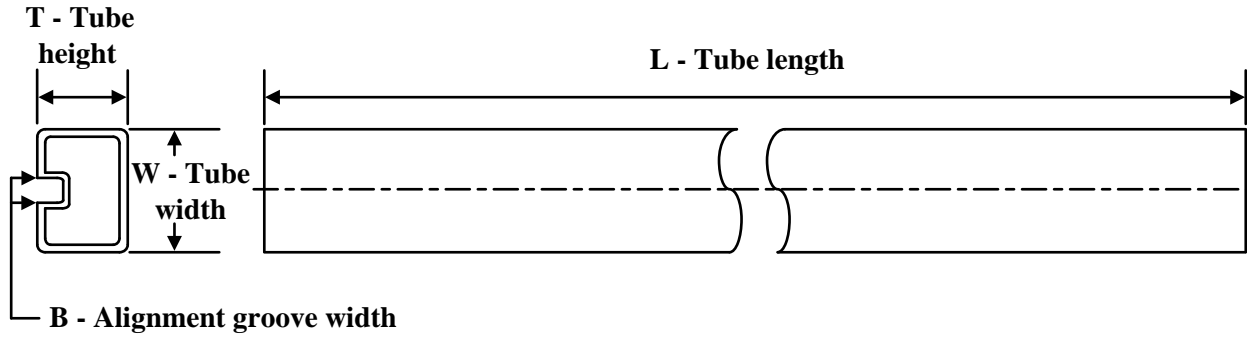
Device	Package Type	Package Drawing	Pins	SPQ	Length (mm)	Width (mm)	Height (mm)
TLV320AIC26IRHBR	VQFN	RHB	32	3000	350.0	350.0	43.0

TUBE

*All dimensions are nominal

Device	Package Name	Package Type	Pins	SPQ	L (mm)	W (mm)	T (μm)	B (mm)
TLV320AIC26IRHB	RHB	VQFN	32	73	381	6.73	2286	0

GENERIC PACKAGE VIEW

RHB 32

VQFN - 1 mm max height

5 x 5, 0.5 mm pitch

PLASTIC QUAD FLATPACK - NO LEAD

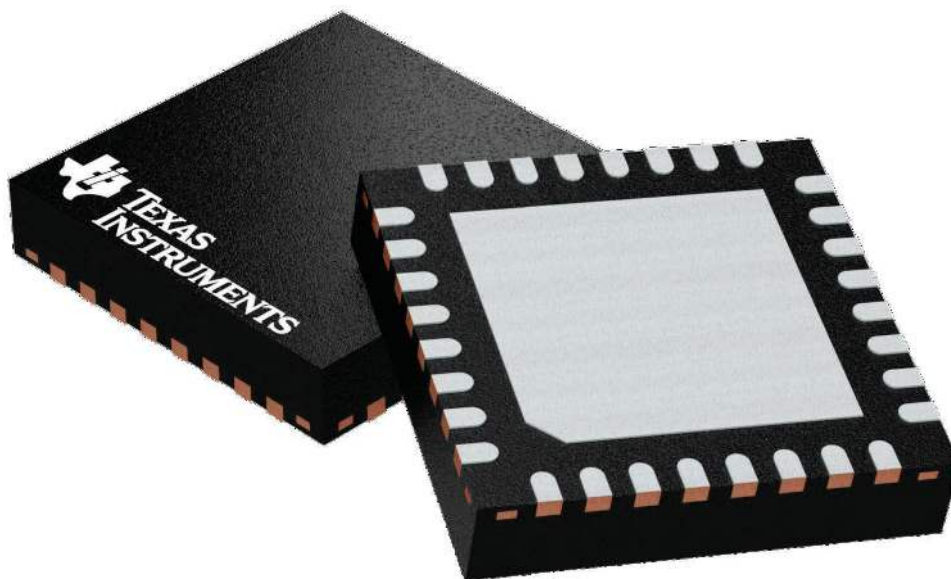

Images above are just a representation of the package family, actual package may vary.
Refer to the product data sheet for package details.

4224745/A

RHB (S-PVQFN-N32)

PLASTIC QUAD FLATPACK NO-LEAD

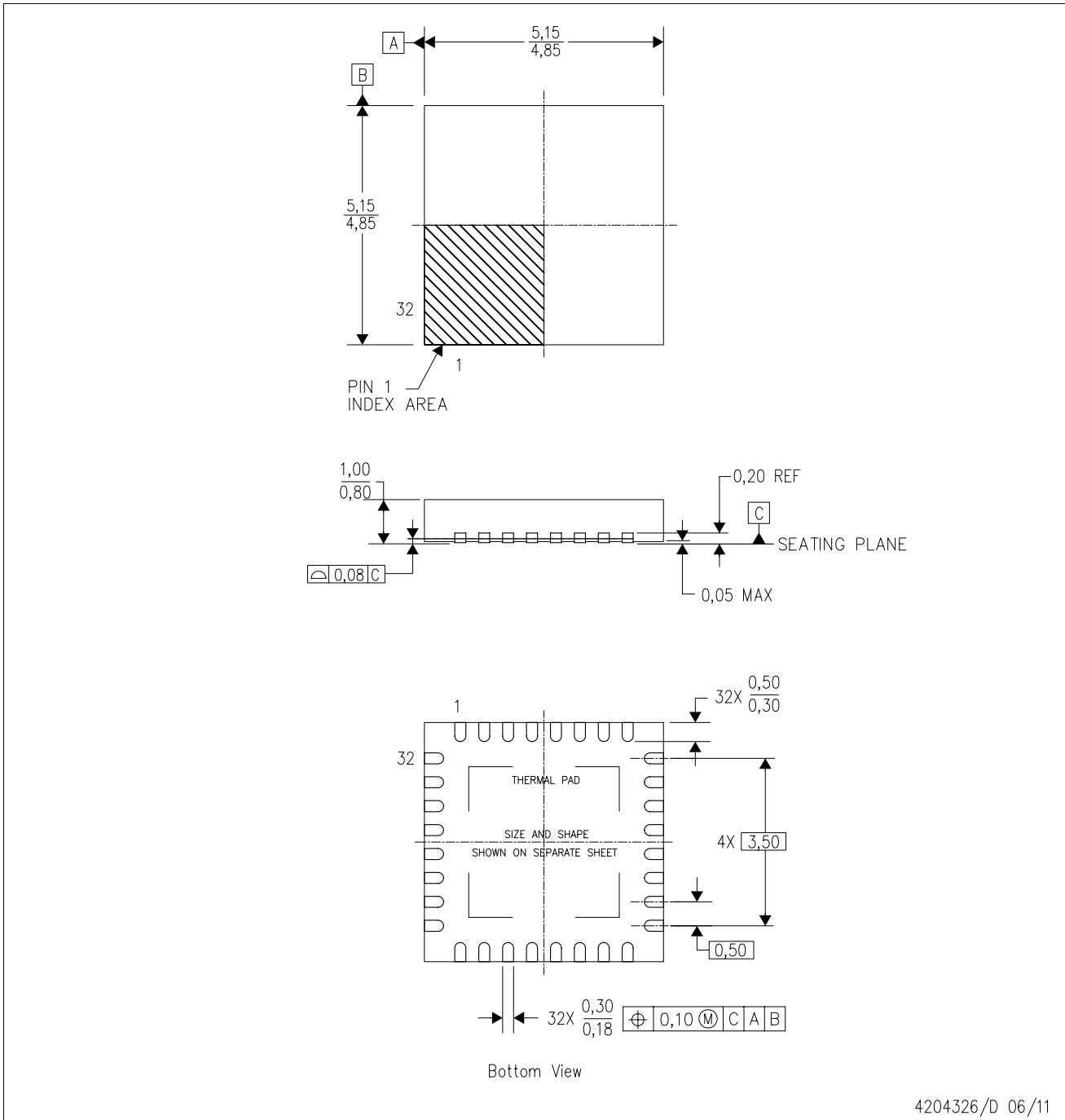

4204326/D 06/11

- NOTES:
- A. All linear dimensions are in millimeters. Dimensioning and tolerancing per ASME Y14.5M-1994.
 - B. This drawing is subject to change without notice.
 - C. QFN (Quad Flatpack No-Lead) Package configuration.
 - D. The package thermal pad must be soldered to the board for thermal and mechanical performance.
 - E. See the additional figure in the Product Data Sheet for details regarding the exposed thermal pad features and dimensions.
 - F. Falls within JEDEC MO-220.

THERMAL INFORMATION

This package incorporates an exposed thermal pad that is designed to be attached directly to an external heatsink. The thermal pad must be soldered directly to the printed circuit board (PCB). After soldering, the PCB can be used as a heatsink. In addition, through the use of thermal vias, the thermal pad can be attached directly to the appropriate copper plane shown in the electrical schematic for the device, or alternatively, can be attached to a special heatsink structure designed into the PCB. This design optimizes the heat transfer from the integrated circuit (IC).

For information on the Quad Flatpack No-Lead (QFN) package and its advantages, refer to Application Report, QFN/SON PCB Attachment, Texas Instruments Literature No. SLUA271. This document is available at www.ti.com.

The exposed thermal pad dimensions for this package are shown in the following illustration.

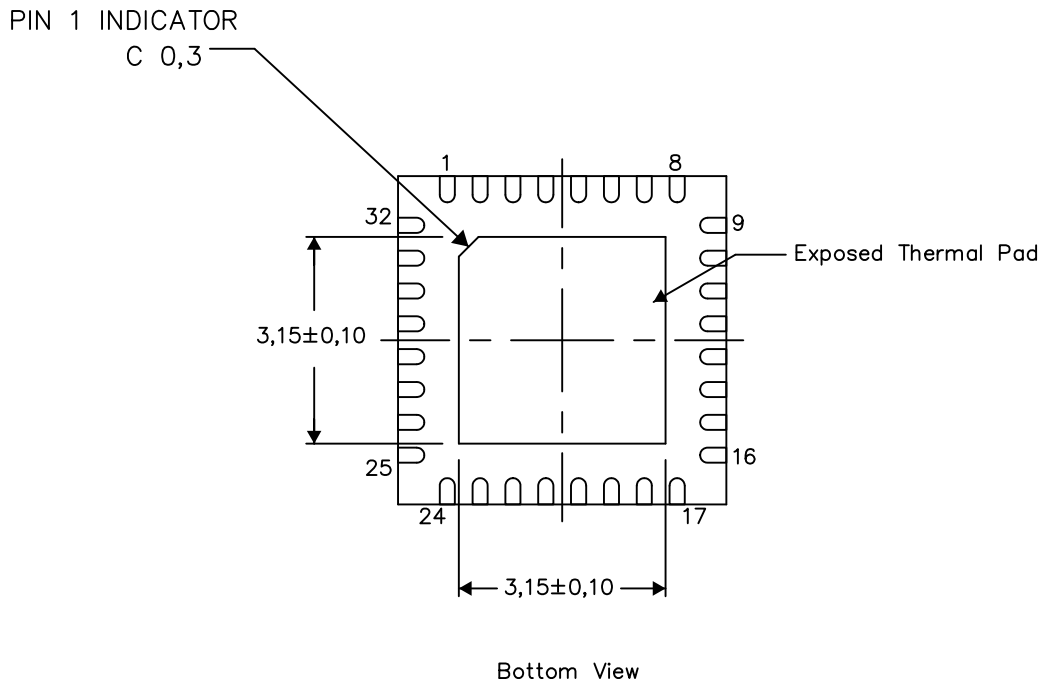

Exposed Thermal Pad Dimensions

4206356-3/AC 05/15

NOTE: A. All linear dimensions are in millimeters

RHB (S-PVQFN-N32)

PLASTIC QUAD FLATPACK NO-LEAD

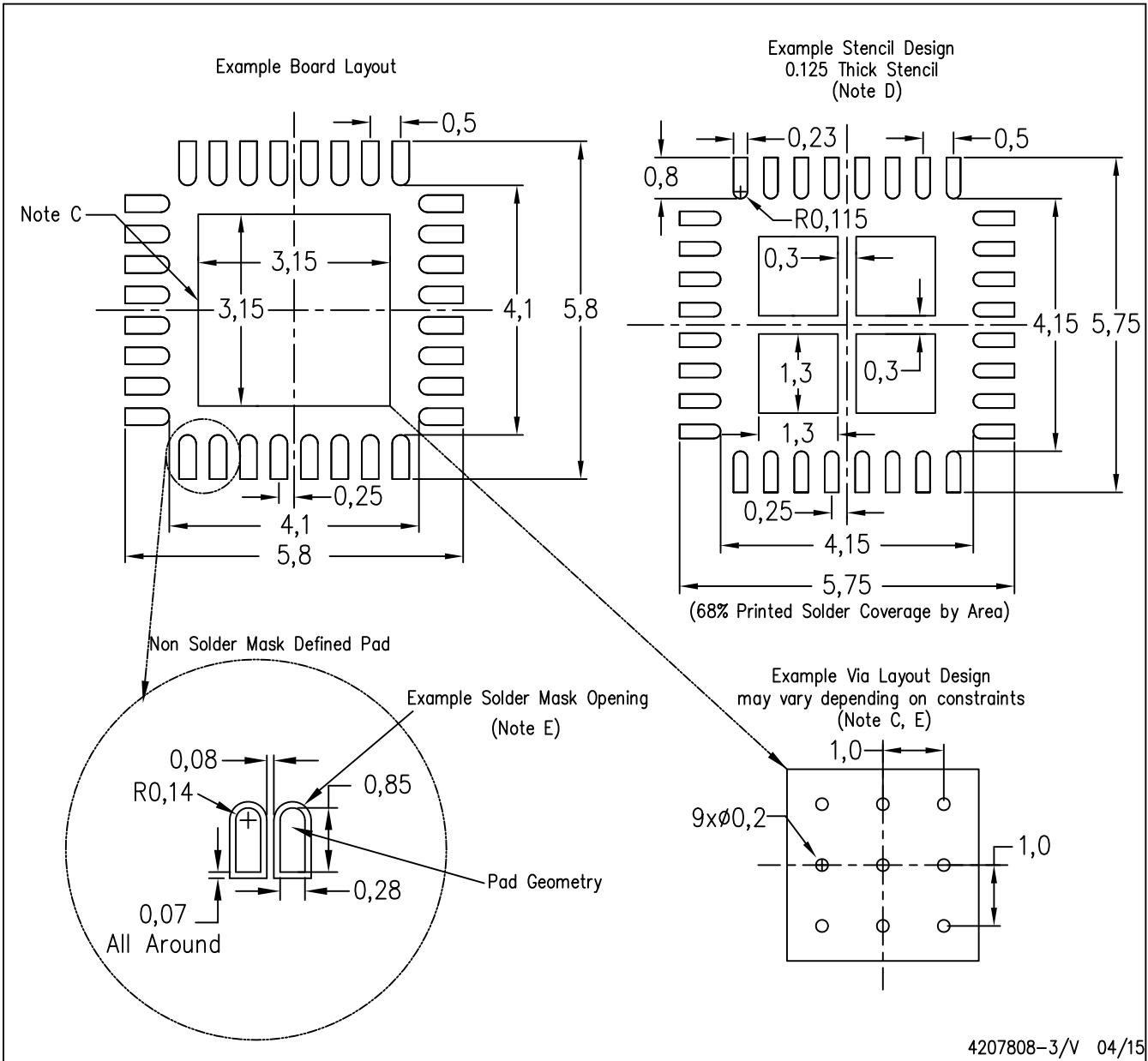

- NOTES:
- All linear dimensions are in millimeters.
 - This drawing is subject to change without notice.
 - This package is designed to be soldered to a thermal pad on the board. Refer to Application Note, Quad Flat-Pack Packages, Texas Instruments Literature No. SLUA271, and also the Product Data Sheets for specific thermal information, via requirements, and recommended board layout. These documents are available at www.ti.com <<http://www.ti.com>>.
 - Laser cutting apertures with trapezoidal walls and also rounding corners will offer better paste release. Customers should contact their board assembly site for stencil design recommendations. Refer to IPC 7525 for stencil design considerations.
 - Customers should contact their board fabrication site for recommended solder mask tolerances and via tenting recommendations for any larger diameter vias placed in the thermal pad.

IMPORTANT NOTICE AND DISCLAIMER

TI PROVIDES TECHNICAL AND RELIABILITY DATA (INCLUDING DATA SHEETS), DESIGN RESOURCES (INCLUDING REFERENCE DESIGNS), APPLICATION OR OTHER DESIGN ADVICE, WEB TOOLS, SAFETY INFORMATION, AND OTHER RESOURCES "AS IS" AND WITH ALL FAULTS, AND DISCLAIMS ALL WARRANTIES, EXPRESS AND IMPLIED, INCLUDING WITHOUT LIMITATION ANY IMPLIED WARRANTIES OF MERCHANTABILITY, FITNESS FOR A PARTICULAR PURPOSE OR NON-INFRINGEMENT OF THIRD PARTY INTELLECTUAL PROPERTY RIGHTS.

These resources are intended for skilled developers designing with TI products. You are solely responsible for (1) selecting the appropriate TI products for your application, (2) designing, validating and testing your application, and (3) ensuring your application meets applicable standards, and any other safety, security, regulatory or other requirements.

These resources are subject to change without notice. TI grants you permission to use these resources only for development of an application that uses the TI products described in the resource. Other reproduction and display of these resources is prohibited. No license is granted to any other TI intellectual property right or to any third party intellectual property right. TI disclaims responsibility for, and you will fully indemnify TI and its representatives against, any claims, damages, costs, losses, and liabilities arising out of your use of these resources.

TI's products are provided subject to [TI's Terms of Sale](#) or other applicable terms available either on [ti.com](https://www.ti.com) or provided in conjunction with such TI products. TI's provision of these resources does not expand or otherwise alter TI's applicable warranties or warranty disclaimers for TI products.

TI objects to and rejects any additional or different terms you may have proposed.

Mailing Address: Texas Instruments, Post Office Box 655303, Dallas, Texas 75265
Copyright © 2023, Texas Instruments Incorporated