

THIS COPY IS PROVIDED ON A RESTRICTED BASIS AND IS NOT TO BE USED IN ANY WAY DETRIMENTAL TO THE INTERESTS OF PANDUIT CORP.

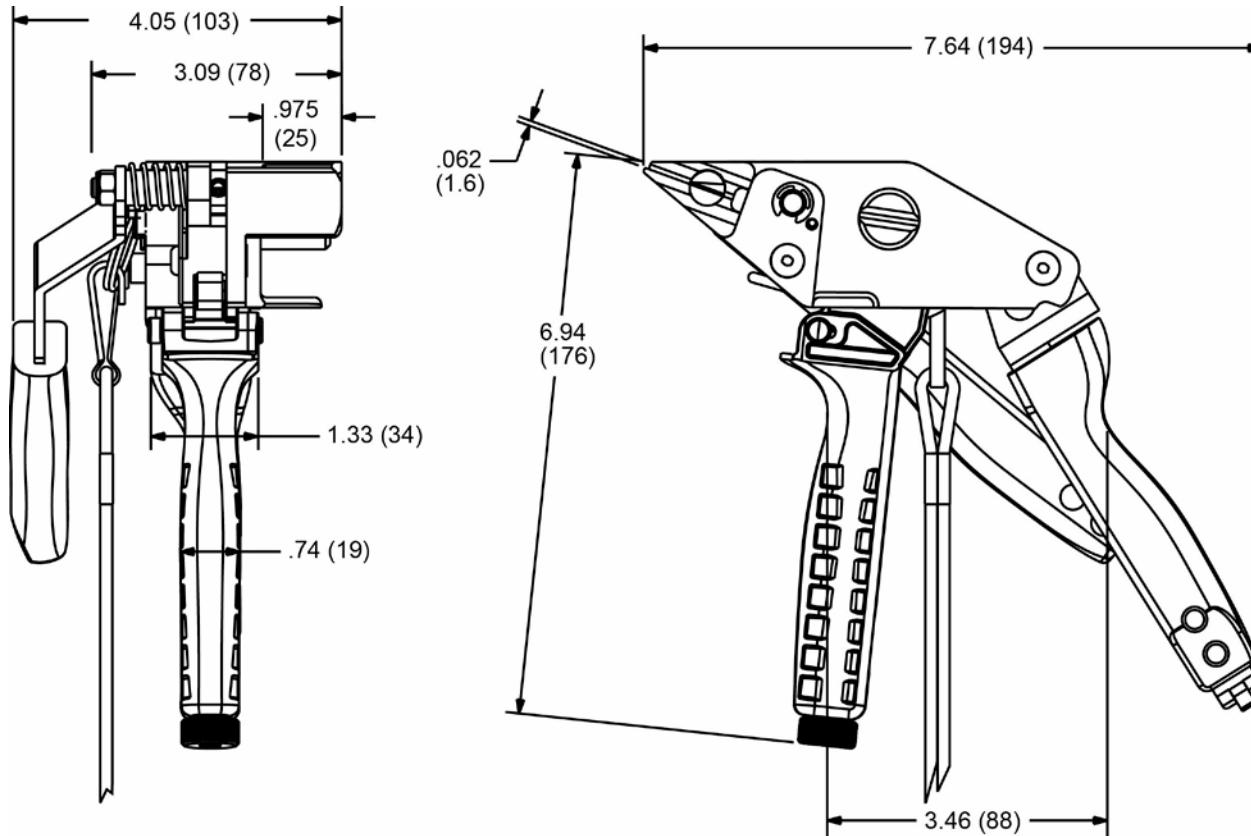

NOTES, UNLESS OTHERWISE SPECIFIED:
 Panduit Tool Number BT2HTI is used to install coated and uncoated Pan-Steel IMS Series strap and buckles in widths of 3/8" (9.5mm), 1/2" (12mm); and 5/8" (16mm).

- THIS TOOLS' FEATURES INCLUDE:**
- Inverted blade provides longer cut-offs
 - Single handle trigger for fast installation
 - Cable strap side entry for immediate positioning of strap and tool
 - Adjustable controlled or Installer controlled tension
 - Cut-off capability with the cutter and cutter handle
 - Easy removal of excess strap.
 - Multi-position rear handle allows access to tight areas.
 - Features to release & remove strap from tool before cutting.

CABLE TIE CROSS-SECTION CODE:
 IMS Series straps and buckles.

TOOL WEIGHT: 2.6 lbs. (41.6 oz.)
 Dimensions shown in parentheses are metric

File Location: Teamcenter

BT2HTI CUSTOMER DRAWING

CUSTOMER DRAWING

ITEM REVISION NAME:

TB28099A01_00



UNLESS OTHERWISE SPECIFIED,
 DIMENSIONAL TOLERANCES ARE:

(.x) ± --- (.xxx) ± ---
 (.xx) ± --- ANGLES ± ---

MATERIAL:

THIRD ANGLE
 PROJECTION

DRAWING NUMBER:
 TB28099A01

00	8-12-16	BLR	<i>BJPU</i>	<i>JADE</i>	RELEASED	10064
REV	DATE	BY	CHK	APR	DESCRIPTION	ECN

DRAWN BY: BLR	DATE: 8-12-16	CHK BJPU	SCALE NONE	SHT 1 OF 1	SIZE A
-------------------------	-------------------------	--------------------	----------------------	-------------------	------------------