

TUSB546 USB Type-C™ Enabler EVM

The TUSB546 USB Type-C™ Alternate Mode re-driving switch supports data rates up to 10 Gbps for a downstream facing port (host). This guide describes how to bring up the EVM and includes schematics that can be used as a reference design for the alternate mode implementations of the host system with the TUSB546 device.

Contents

1	TUSB546EVM-SRC	2
2	TUSB546EVM Configuration	2
	2.1 TUSB546 EVM Default EQ Configuration	2
	2.2 TUSB546 EQ Control	3
	2.3 Power.....	4
3	TUSB546EVM Schematics	5
4	Bill of Materials	10

List of Figures

1	TUSB546 EVM.....	2
2	Test Board Setup	2
3	TUSB546EVM Block Diagram	5
4	TUSB546EVM Schematics (1 of 4)	6
5	TUSB546EVM Schematics (2 of 4)	7
6	TUSB546EVM Schematics (3 of 4)	8
7	TUSB546EVM Schematics (4 of 4)	9

List of Tables

1	TUSB546 Configuration Pins.....	2
2	Configuration Pin-Level Definitions.....	3
3	USB 3.1 EQ Settings.....	3
4	DisplayPort EQ Settings	4
5	TUSB546 EVM Bill of Materials	10

1 TUSB546EVM-SRC

Figure 1 illustrates the EVM board.



Figure 1. TUSB546 EVM

The TUSB546EVM-SRC can be used with a legacy DP Source or USB Host system to evaluate the USB Type-C implementation. Figure 2 is a typical test setup.

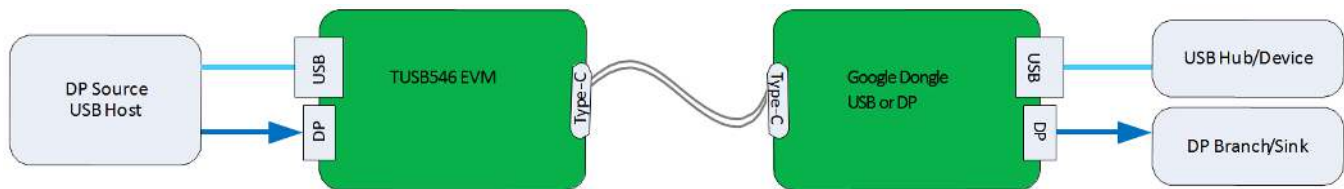

Figure 2. Test Board Setup

The EVM comes with a legacy Type B USB receptacle to connect to USB host systems and a DisplayPort receptacle to connect to DisplayPort-capable source. The TUSB546 EVM uses the Texas Instruments TPS65982 (<http://www.ti.com/product/TPS65982>) controller for power delivery and CC pin control.

2 TUSB546EVM Configuration

This section provides the configuration options available in the TUSB546EVM.

2.1 TUSB546 EVM Default EQ Configuration

The headers in Table 1 are provided for TUSB546 EQ configuration by default, configuration settings may need to be optimized depending on the amount of loss of each channel in the system.

Table 1. TUSB546 Configuration Pins

Reference Designator	JMP Control	Configuration
JMP1	Downstream EQ0	No Connect
JMP2	Downstream EQ1	SHUNT on pin 2–4 (20-kΩ pulldown)
JMP3	Upstream SSEQ0	SHUNT on pin 2–1 (1-kΩ pullup)
JMP4	Upstream SSEQ1	SHUNT on pin 2–4 (20-kΩ pulldown)
JMP5	DP EQ0	SHUNT on pin 2–4 (20-kΩ pulldown)
JMP6	DP EQ1	SHUNT on pin 2–4 (20-kΩ pulldown)

2.2 TUSB546 EQ Control

Each of the TUSB546 receiver lanes has individual controls for receiver equalization. [Table 2](#), [Table 3](#), and [Table 4](#) detail the gain values for each available combination for downstream, upstream, and all DisplayPort configurations.

Table 2. Configuration Pin-Level Definitions

Level	Settings
0	Option 1: Tie 1 kΩ 5% to GND Option 2: Tie directly to GND
R	Tie 20 kΩ, 5% to GND
F	Float (leave pin open)
1	Option 1: Tie 1 kΩ 5% to VCC Option 2: Tie directly to VCC

Table 3. USB 3.1 EQ Settings

USB3.1 Downstream Facing Ports			USB3.1 Upstream Facing Port		
EQ1 Pin Level	EQ0 Pin Level	EQ Gain @ 5 GHz (dB)	SSEQ1 Pin Level	SSEQ0 Pin Level	EQ Gain @ 5 GHz (dB)
0	0	0	0	0	0
0	R	1	0	R	1
0	F	2	0	F	2
0	1	3	0	1	3
R	0	4	R	0	4
R	R	5	R	R	5
R	F	6	R	F	6
R	1	7	R	1	7
F	0	8	F	0	8
F	R	9	F	R	9
F	F	10	F	F	10
F	1	11	F	1	11
1	0	12	1	0	12
1	R	13	1	R	13
1	F	14	1	F	14
1	1	15	1	1	15

Table 4. DisplayPort EQ Settings

All DisplayPort Lanes		
DPEQ1 Pin Level	DPEQ0 Pin Level	EQ Gain @ 5 GHz (dB)
0	0	0
0	R	1
0	F	2
0	1	3
R	0	4
R	R	5
R	F	6
R	1	7
F	0	8
F	R	9
F	F	10
F	1	11
1	0	12
1	R	13
1	F	14
1	1	15

2.3 Power

The EVM is designed to operate off of the VBUS from a USB host connected via USB Type B J4. No external power is to be applied via J14 unless standalone operation is desired.

If testing the DisplayPort only, or if bypassing VBUS power, the EVM must be powered via J14 (5-V, 1-A input).

3 TUSB546EVM Schematics

Figure 3 displays the block diagram of the EVM.

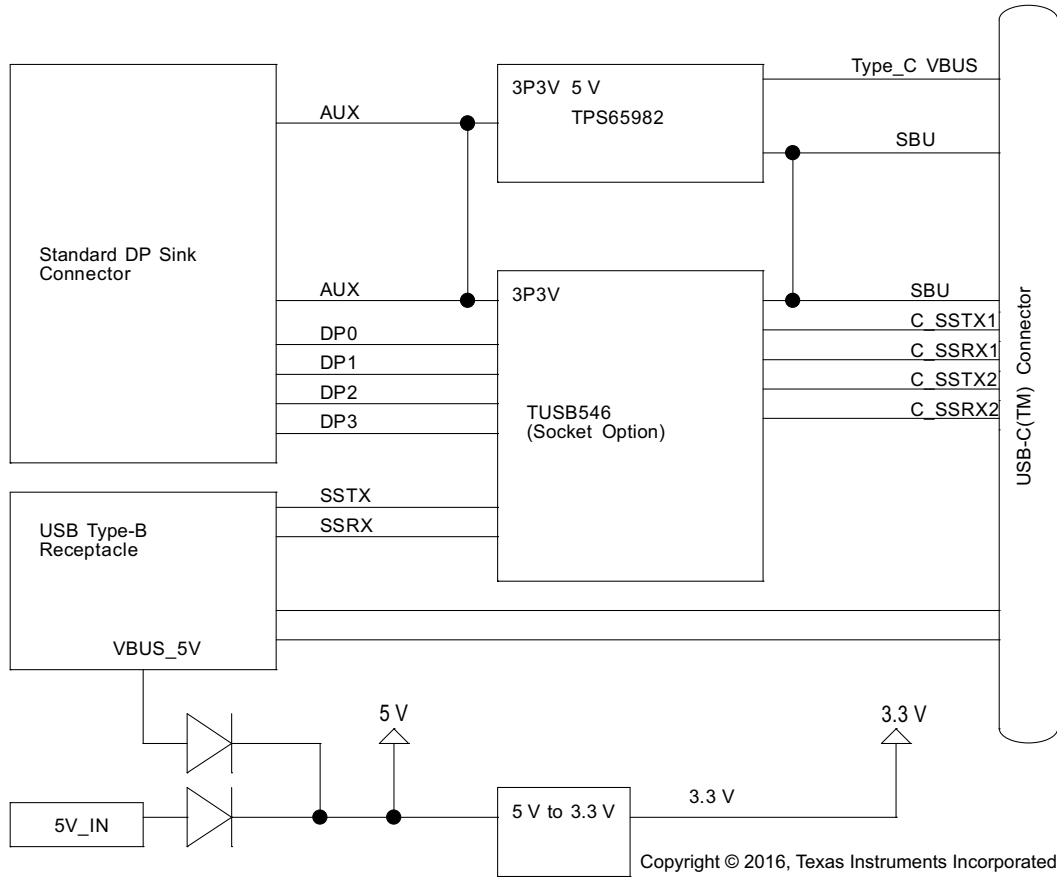
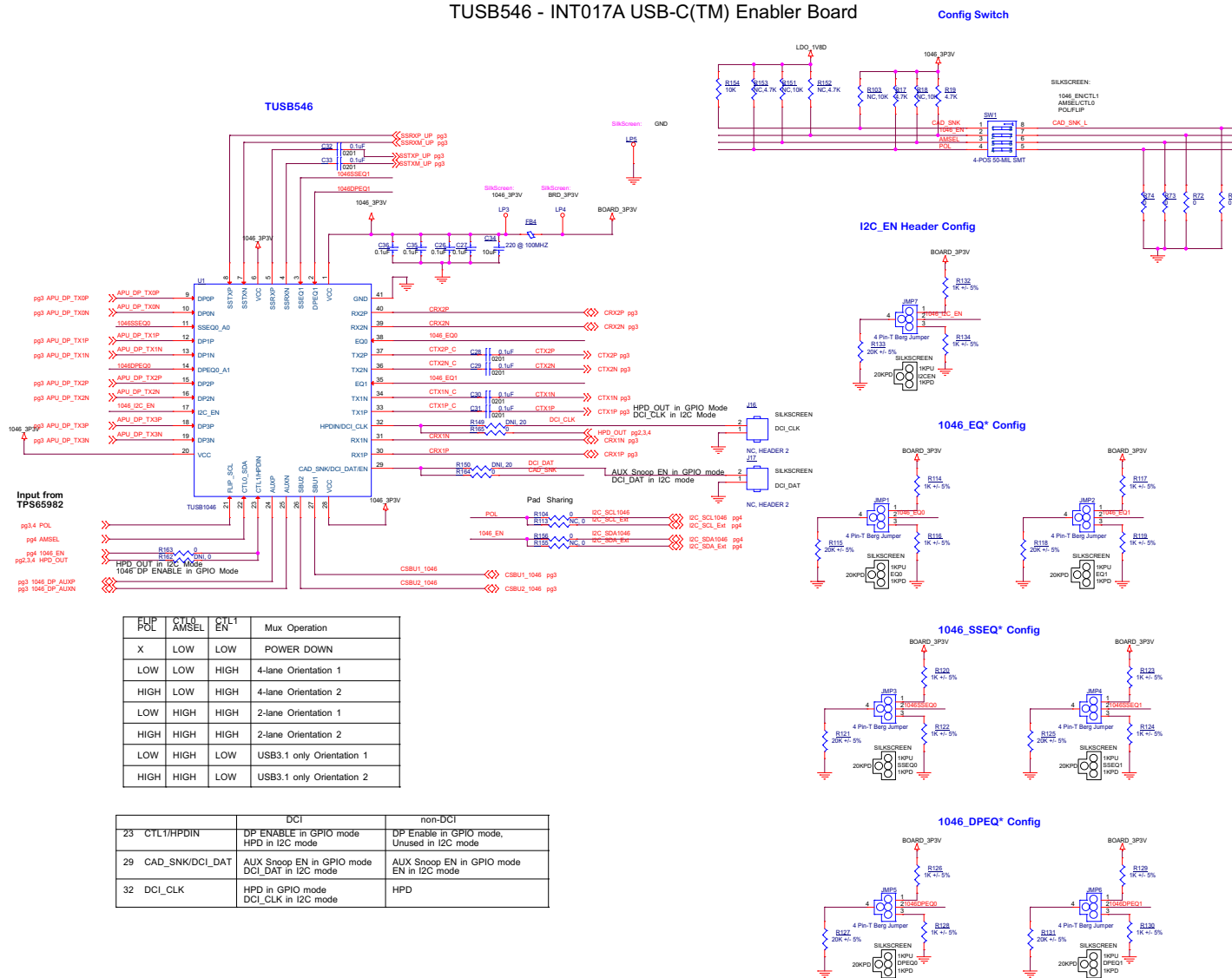

Figure 3. TUSB546EVM Block Diagram

Figure 4 through Figure 7 show the EVM schematics.

TUSB546 - INT017A USB-C(TM) Enabler Board



DCI	AMSEL	EN	Mux Operation
X	LOW	LOW	POWER DOWN
LOW	LOW	HIGH	4-lane Orientation 1
HIGH	LOW	HIGH	4-lane Orientation 2
LOW	HIGH	HIGH	2-lane Orientation 1
HIGH	HIGH	HIGH	2-lane Orientation 2
LOW	HIGH	LOW	USB3.1 only Orientation 1
HIGH	HIGH	LOW	USB3.1 only Orientation 2

	DCI	non-DCI
23 CTL1/HPDIN	DP ENABLE in GPIO mode HPD in I2C mode	DP Enable in GPIO mode, Unused in I2C mode
29 CAD_SNK/DCI_DAT	AUX Snoop EN in GPIO mode DCI_DAT in I2C mode	AUX Snoop EN in GPIO mode EN in I2C mode
32 DCI_CLK	HPD in GPIO mode DCI_CLK in I2C mode	HPD

Copyright © 2016, Texas Instruments Incorporated

Figure 4. TUSB546EVM Schematics (1 of 4)

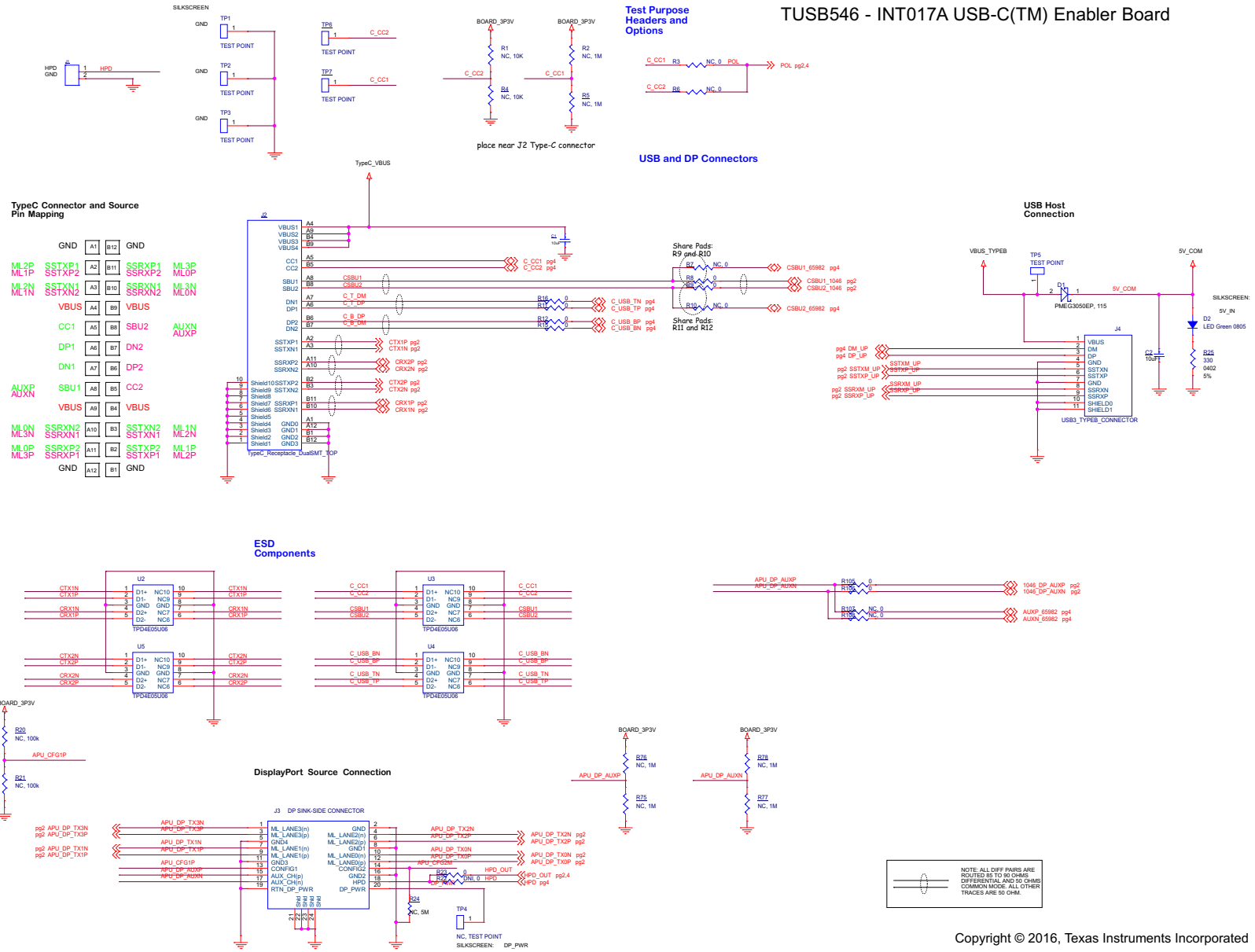
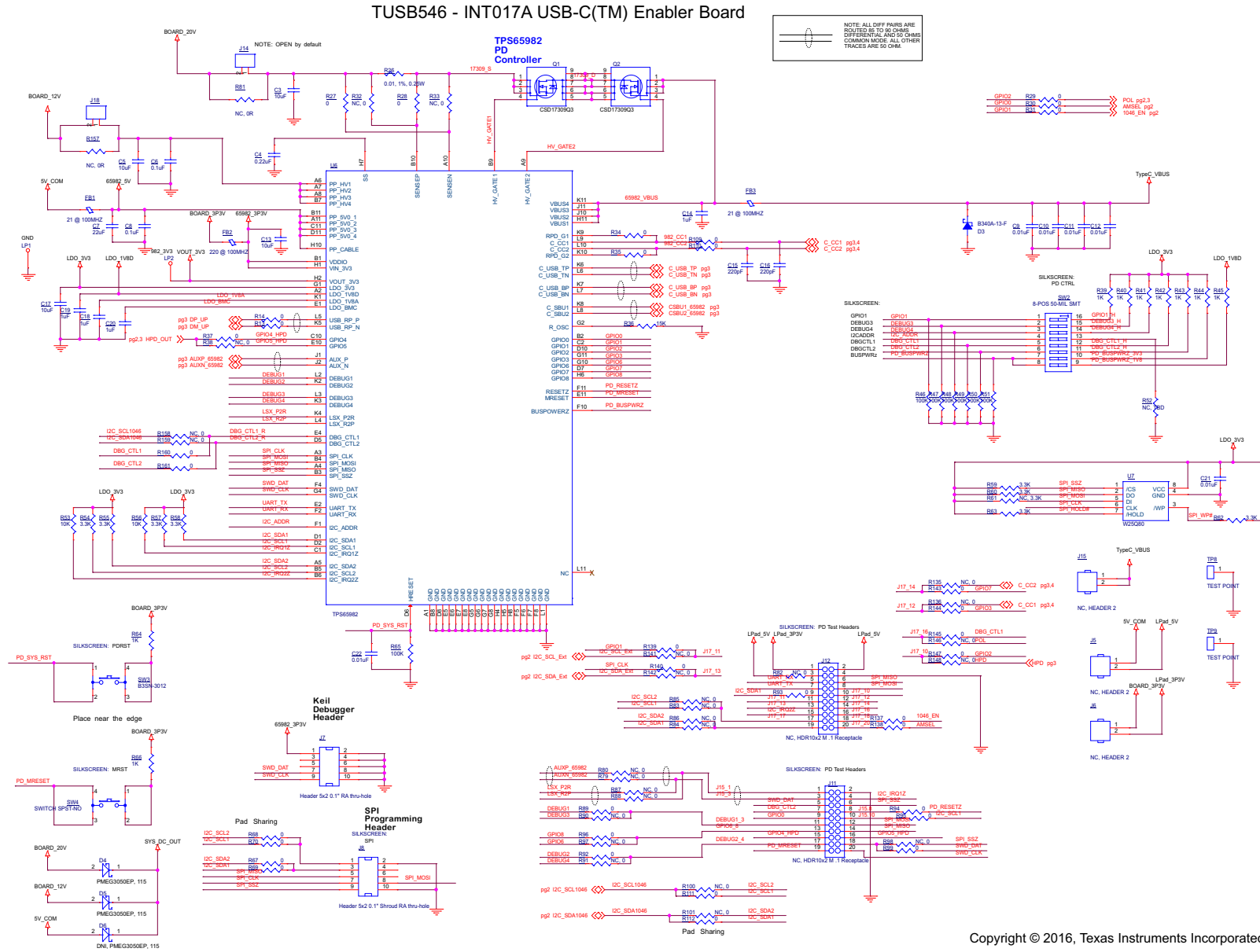

Figure 5. TUSB546EVM Schematics (2 of 4)

Copyright © 2016, Texas Instruments Incorporated



Copyright © 2016, Texas Instruments Incorporated

TUSB546 - INT017A USB-C(TM) Enabler Board

Power

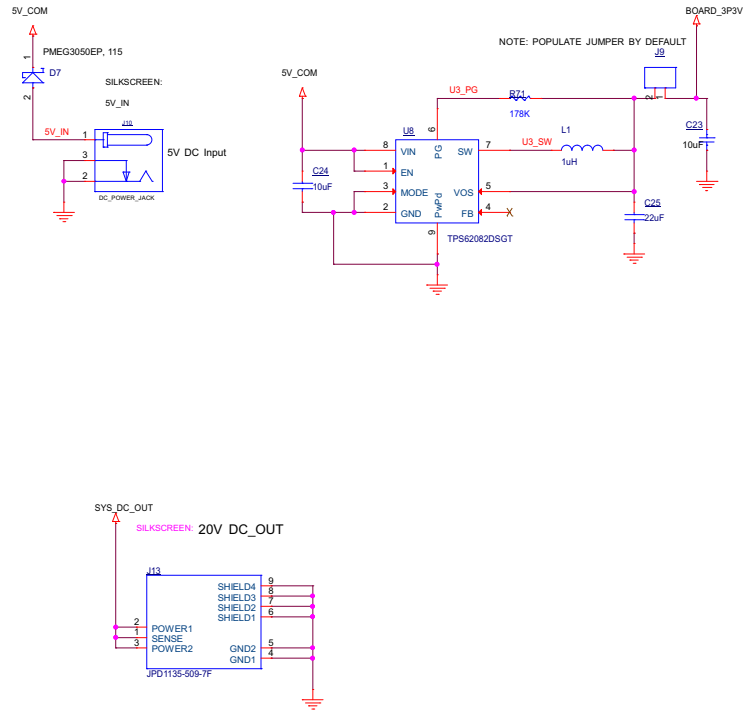

Copyright © 2016, Texas Instruments Incorporated

Figure 7. TUSB546EVM Schematics (4 of 4)

4 Bill of Materials

Table 5 lists the TUSB546EVM bill of materials (BOM).

Table 5. TUSB546 EVM Bill of Materials

Item	Qty	Reference	Part	Manufacturer	Manufacturer Part Number	PCB Footprint
1	9	C1,C2,C3,C5,C13,C17,C23,C24,C34	10uF	Murata	GRM188R61C106MA73D	603
2	1	C4	0.22uF	Murata	GRM152R61A224KE19D	402
3	12	C6,C8,C26,C27,C28,C29,C30,C31,C32,C33,C35,C36	0.1uF	Murata	GRM155R61A104KA01D	402
4	2	C7,C25	22uF	Murata	GRM188R60J226MEA0D	603
5	6	C9,C10,C11,C12,C21,C22	0.01uF	Murata	GRM155R71C103KA01D	402
6	4	C14,C18,C19,C20	1uF	Murata	GRM155R60J105ME19D	402
7	2	C15,C16	220pF	Murata	GRM1555C1H221JA01D	402
8	5	D1,D4,D5,D6,D7	SCHOTTKY	NXP	PMEG3050EP,115	SOD-128
9	1	D2	LED Green 0805	Lumex	SML-LX0805GC-TR	805
10	1	D3	B340A-13-F	Diodes Inc	B340A-13-F	
11	2	FB1,FB3	21 @ 100MHZ	Taiyo Yuden	FBMJ2125HM210NT	
12	2	FB2,FB4	220 @ 100MHZ	MuRata	BLM18EG221SN1D	
13	7	JMP1,JMP2,JMP3,JMP4,JMP5,JMP6,JMP7	4 Pin-T Berg Jumper			berg2x3tee
14	4	J1,J9,J14,J18	CON02	FCI	68001-402HLF	HDR_THVT_1X2_100_M
15	1	J2	TypeC_Receptacle_DualSMT_TOP	Foxconn	UT12113-11601-7H	USB_TYPEC_UT1211
16	1	J3	DP SINK-SIDE CONNECTOR	Molex Inc	472720001	con_DP_SD-47272-001
17	1	J4	USB3_TYPEB_CONNECTOR	Amphenol Commercial Products	GSB4211311WEU	usb3_typeb_ak4aa009
18	5	J5,J6,J15,J16,J17	NC, HEADER 2	Omron Electronics Inc-EMC Div	XG8T-0231	berg1x2
19	1	J7	Header 5x2 0.1" RA thru-hole	FCI	68021-210HLF	HDR_THRT_68020
20	1	J8	Header 5x2 0.1" Shroud RA thru-hole	3M	20210-5002HB	HDR_THRT_2X5_100
21	1	J10	DC_PWR_JACK	CUI Inc.	PJ-202AH	pj-202ah
22	2	J11,J12	NC, HDR10x2 M .1 Receptacle	Sullins	PPPC102LFBN-RC	HDR_THVT_2x10_100_F
23	1	J13	JPD1135-509-7F	Foxconn	JPD1135-509-7F	Jack_THRT_JPD1135
24	2	LP1,LP5	LP	Keystone Electronics	5011	THM Test Point
25	3	LP2,LP3,LP4,		Keystone Electronics	5010	THM Test Point
26	1	L1	1uH	Taiyo Yuden	NR3015T1R0N	IND_NR3015
27	2	Q1,Q2	MOS_P_4D_3S	Texas Instruments	CSD17309Q3	Q3_SON-8

Table 5. TUSB546 EVM Bill of Materials (continued)

Item	Qty	Reference	Part	Manufacturer	Manufacturer Part Number	PCB Footprint
28	2	R1,R4	NC, 10K	Panasonic Electronic Components	ERJ-2GEJ103X	402
29	6	R2,R5,R75,R76,R77,R78	NC, 1M	Panasonic Electronic Components	ERJ-2GEJ105X	402
30	34	R3,R6,R7,R10,R32,R33,R38,R79,R80,R82,R83,R84,R85,R86,R87,R88,R90,R91,R97,R98,R100,R101,R107,R108,R113,R135,R136,R141,R142,R146,R148,R155,R158,R159	NC, 0	Panasonic Electronic Components	ERJ-2GE0R00X	402
31	53	R8,R9,R11,R12,R13,R14,R15,R16,R23,R27,R28,R29,R30,R31,R34,R35,R37,R67,R68,R69,R70,R72,R73,R74,R89,R92,R93,R94,R95,R96,R99,R102,R104,R105,R106,R109,R110,R111,R112,R137,R138,R139,R140,R143,R144,R145,R147,R156,R160,R161,R163,R164,R165	0	Panasonic Electronic Components	ERJ-2GE0R00X	402
32	2	R17,R19	4.7K	Panasonic Electronic Components	ERJ-2GEJ472X	402
33	3	R18,R103,R151	NC, 10K	Panasonic Electronic Components	ERJ-2GEJ103X	402
34	2	R20,R21	NC, 100k	Panasonic Electronic Components	ERJ-2GEJ104X	402
35	2	R22,R162	DNI, 0	Panasonic Electronic Components	ERJ-1GN0R00C	201
36	1	R24	NC, 1M	Panasonic Electronic Components	ERJ-1GEF1004C	201
37	1	R25	330	Panasonic Electronic Components	ERJ-2GEJ331X	402
38	1	R26	0.01, 1%, 0.25W	Panasonic Electronic Components	ERJ-6BWFR010V	805
39	1	R36	15K	Panasonic Electronic Components	ERJ-2RKF1502X	402
40	9	R39,R40,R41,R42,R43,R44,R45,R64,R66	1K	Panasonic Electronic Components	ERJ-2GEJ102X	402
41	7	R46,R47,R48,R49,R50,R51,R65	100K	Panasonic Electronic Components	ERJ-2GEJ104X	402
42	1	R52	NC, 100	Panasonic Electronic Components	ERJ-2GEJ101X	402
43	3	R53,R56,R154	10K	Panasonic Electronic Components	ERJ-2GEJ103X	402
44	8	R54,R55,R57,R58,R59,R60,R62,R63	3.3K	Panasonic Electronic Components	ERJ-2GEJ332X	402
45	1	R61	NC, 3.3K	Panasonic Electronic Components	ERJ-2GEJ332X	402
46	1	R71	178K	Panasonic Electronic Components	ERJ-3EKF1783V	603
47	2	R81,R157	NC, 0R	Vishay Dale	RCL12250000Z0EG	2512
48	14	R114,R116,R117,R119,R120,R122,R123,R124,R126,R128,R129,R130,R132,R134	1K +/- 5%	Panasonic Electronic Components	ERJ-2GEJ102X	402

Table 5. TUSB546 EVM Bill of Materials (continued)

Item	Qty	Reference	Part	Manufacturer	Manufacturer Part Number	PCB Footprint
49	7	R115,R118,R121,R125,R127,R131,R133	20K +/- 5%	Panasonic Electronic Components	ERJ-2GEJ203X	402
50	2	R149,R150	DNI, 20	Panasonic Electronic Components	ERJ-2GEJ200X	402
51	2	R152,R153	NC,4.7K	Panasonic Electronic Components	ERJ-2GEJ472X	402
52	1	SW1	4-POS 50-MIL SMT	CampersandK(ITT-CANNON)	TDA04H0SB1R	sw_smvt_dip_4pos_8
53	1	SW2	8-POS 50-MIL SMT	CampersandK(ITT-CANNON)	TDA08H0SB1R	SW_SMVT_SPST_TDA08
54	1	SW3	Pushbutton Switch	Omron Electronics Inc-EMC Div	B3SN-3012P	switch_b3sn
55	1	SW4	SWITCH SPST-NO	CampersandK Components	KMT221G HF LFS	kmt2_switch
56	8	TP1,TP2,TP3,TP5,TP6,TP7,TP8,TP9	TEST POINT	Samtec	HTSW-101-07-G-S	berg1x1
57	1	TP4	NC, TEST POINT	Keystone Electronics	1035	berg1x1
58	1	U1	TUSB546	Texas Instruments	TUSB546	
59	4	U2,U3,U4,U5	TPD4E05U06	Texas Instruments	TPD4E05U06	DQA
60	1	U6	TPS65982	Texas Instruments	TPS65982	ZQZ_BGA_96
61	1	U7	W25Q80	WINBOND	W25Q80DVSNIG	SOIC_8_197x157_50
62	1	U8	TPS62082DSGT	Texas Instruments	TPS62082DSGT	dsg

STANDARD TERMS AND CONDITIONS FOR EVALUATION MODULES

1. *Delivery:* TI delivers TI evaluation boards, kits, or modules, including any accompanying demonstration software, components, or documentation (collectively, an "EVM" or "EVMs") to the User ("User") in accordance with the terms and conditions set forth herein. Acceptance of the EVM is expressly subject to the following terms and conditions.
 - 1.1 EVMs are intended solely for product or software developers for use in a research and development setting to facilitate feasibility evaluation, experimentation, or scientific analysis of TI semiconductors products. EVMs have no direct function and are not finished products. EVMs shall not be directly or indirectly assembled as a part or subassembly in any finished product. For clarification, any software or software tools provided with the EVM ("Software") shall not be subject to the terms and conditions set forth herein but rather shall be subject to the applicable terms and conditions that accompany such Software
 - 1.2 EVMs are not intended for consumer or household use. EVMs may not be sold, sublicensed, leased, rented, loaned, assigned, or otherwise distributed for commercial purposes by Users, in whole or in part, or used in any finished product or production system.
2. *Limited Warranty and Related Remedies/Disclaimers:*
 - 2.1 These terms and conditions do not apply to Software. The warranty, if any, for Software is covered in the applicable Software License Agreement.
 - 2.2 TI warrants that the TI EVM will conform to TI's published specifications for ninety (90) days after the date TI delivers such EVM to User. Notwithstanding the foregoing, TI shall not be liable for any defects that are caused by neglect, misuse or mistreatment by an entity other than TI, including improper installation or testing, or for any EVMs that have been altered or modified in any way by an entity other than TI. Moreover, TI shall not be liable for any defects that result from User's design, specifications or instructions for such EVMs. Testing and other quality control techniques are used to the extent TI deems necessary or as mandated by government requirements. TI does not test all parameters of each EVM.
 - 2.3 If any EVM fails to conform to the warranty set forth above, TI's sole liability shall be at its option to repair or replace such EVM, or credit User's account for such EVM. TI's liability under this warranty shall be limited to EVMs that are returned during the warranty period to the address designated by TI and that are determined by TI not to conform to such warranty. If TI elects to repair or replace such EVM, TI shall have a reasonable time to repair such EVM or provide replacements. Repaired EVMs shall be warranted for the remainder of the original warranty period. Replaced EVMs shall be warranted for a new full ninety (90) day warranty period.
3. *Regulatory Notices:*
 - 3.1 *United States*
 - 3.1.1 *Notice applicable to EVMs not FCC-Approved:*

This kit is designed to allow product developers to evaluate electronic components, circuitry, or software associated with the kit to determine whether to incorporate such items in a finished product and software developers to write software applications for use with the end product. This kit is not a finished product and when assembled may not be resold or otherwise marketed unless all required FCC equipment authorizations are first obtained. Operation is subject to the condition that this product not cause harmful interference to licensed radio stations and that this product accept harmful interference. Unless the assembled kit is designed to operate under part 15, part 18 or part 95 of this chapter, the operator of the kit must operate under the authority of an FCC license holder or must secure an experimental authorization under part 5 of this chapter.
 - 3.1.2 *For EVMs annotated as FCC – FEDERAL COMMUNICATIONS COMMISSION Part 15 Compliant:*

CAUTION

This device complies with part 15 of the FCC Rules. Operation is subject to the following two conditions: (1) This device may not cause harmful interference, and (2) this device must accept any interference received, including interference that may cause undesired operation.

Changes or modifications not expressly approved by the party responsible for compliance could void the user's authority to operate the equipment.

FCC Interference Statement for Class A EVM devices

NOTE: This equipment has been tested and found to comply with the limits for a Class A digital device, pursuant to part 15 of the FCC Rules. These limits are designed to provide reasonable protection against harmful interference when the equipment is operated in a commercial environment. This equipment generates, uses, and can radiate radio frequency energy and, if not installed and used in accordance with the instruction manual, may cause harmful interference to radio communications. Operation of this equipment in a residential area is likely to cause harmful interference in which case the user will be required to correct the interference at his own expense.

FCC Interference Statement for Class B EVM devices

NOTE: This equipment has been tested and found to comply with the limits for a Class B digital device, pursuant to part 15 of the FCC Rules. These limits are designed to provide reasonable protection against harmful interference in a residential installation. This equipment generates, uses and can radiate radio frequency energy and, if not installed and used in accordance with the instructions, may cause harmful interference to radio communications. However, there is no guarantee that interference will not occur in a particular installation. If this equipment does cause harmful interference to radio or television reception, which can be determined by turning the equipment off and on, the user is encouraged to try to correct the interference by one or more of the following measures:

- Reorient or relocate the receiving antenna.
- Increase the separation between the equipment and receiver.
- Connect the equipment into an outlet on a circuit different from that to which the receiver is connected.
- Consult the dealer or an experienced radio/TV technician for help.

3.2 Canada

3.2.1 For EVMs issued with an Industry Canada Certificate of Conformance to RSS-210

Concerning EVMs Including Radio Transmitters:

This device complies with Industry Canada license-exempt RSS standard(s). Operation is subject to the following two conditions: (1) this device may not cause interference, and (2) this device must accept any interference, including interference that may cause undesired operation of the device.

Concernant les EVMs avec appareils radio:

Le présent appareil est conforme aux CNR d'Industrie Canada applicables aux appareils radio exempts de licence. L'exploitation est autorisée aux deux conditions suivantes: (1) l'appareil ne doit pas produire de brouillage, et (2) l'utilisateur de l'appareil doit accepter tout brouillage radioélectrique subi, même si le brouillage est susceptible d'en compromettre le fonctionnement.

Concerning EVMs Including Detachable Antennas:

Under Industry Canada regulations, this radio transmitter may only operate using an antenna of a type and maximum (or lesser) gain approved for the transmitter by Industry Canada. To reduce potential radio interference to other users, the antenna type and its gain should be so chosen that the equivalent isotropically radiated power (e.i.r.p.) is not more than that necessary for successful communication. This radio transmitter has been approved by Industry Canada to operate with the antenna types listed in the user guide with the maximum permissible gain and required antenna impedance for each antenna type indicated. Antenna types not included in this list, having a gain greater than the maximum gain indicated for that type, are strictly prohibited for use with this device.

Concernant les EVMs avec antennes détachables

Conformément à la réglementation d'Industrie Canada, le présent émetteur radio peut fonctionner avec une antenne d'un type et d'un gain maximal (ou inférieur) approuvé pour l'émetteur par Industrie Canada. Dans le but de réduire les risques de brouillage radioélectrique à l'intention des autres utilisateurs, il faut choisir le type d'antenne et son gain de sorte que la puissance isotrope rayonnée équivalente (p.i.r.e.) ne dépasse pas l'intensité nécessaire à l'établissement d'une communication satisfaisante. Le présent émetteur radio a été approuvé par Industrie Canada pour fonctionner avec les types d'antenne énumérés dans le manuel d'usage et ayant un gain admissible maximal et l'impédance requise pour chaque type d'antenne. Les types d'antenne non inclus dans cette liste, ou dont le gain est supérieur au gain maximal indiqué, sont strictement interdits pour l'exploitation de l'émetteur.

3.3 Japan

3.3.1 *Notice for EVMs delivered in Japan:* Please see http://www.tij.co.jp/lstds/ti_ja/general/eStore/notice_01.page 日本国内に輸入される評価用キット、ボードについては、次のところをご覧ください。
http://www.tij.co.jp/lstds/ti_ja/general/eStore/notice_01.page

3.3.2 *Notice for Users of EVMs Considered "Radio Frequency Products" in Japan:* EVMs entering Japan may not be certified by TI as conforming to Technical Regulations of Radio Law of Japan.

If User uses EVMs in Japan, not certified to Technical Regulations of Radio Law of Japan, User is required by Radio Law of Japan to follow the instructions below with respect to EVMs:

1. Use EVMs in a shielded room or any other test facility as defined in the notification #173 issued by Ministry of Internal Affairs and Communications on March 28, 2006, based on Sub-section 1.1 of Article 6 of the Ministry's Rule for Enforcement of Radio Law of Japan,
2. Use EVMs only after User obtains the license of Test Radio Station as provided in Radio Law of Japan with respect to EVMs, or
3. Use of EVMs only after User obtains the Technical Regulations Conformity Certification as provided in Radio Law of Japan with respect to EVMs. Also, do not transfer EVMs, unless User gives the same notice above to the transferee. Please note that if User does not follow the instructions above, User will be subject to penalties of Radio Law of Japan.

【無線電波を送信する製品の開発キットをお使いになる際の注意事項】 開発キットの中には技術基準適合証明を受けていないものがあります。技術適合証明を受けていないものご使用に際しては、電波法遵守のため、以下のいずれかの措置を取っていただく必要がありますのでご注意ください。

1. 電波法施行規則第6条第1項第1号に基づく平成18年3月28日総務省告示第173号で定められた電波暗室等の試験設備でご使用いただく。
2. 実験局の免許を取得後ご使用いただく。
3. 技術基準適合証明を取得後ご使用いただく。

なお、本製品は、上記の「ご使用にあたっての注意」を譲渡先、移転先に通知しない限り、譲渡、移転できないものとします。

上記を遵守頂けない場合は、電波法の罰則が適用される可能性があることをご留意ください。日本テキサス・インスツルメンツ株式会社

東京都新宿区西新宿 6 丁目 2 4 番 1 号

西新宿三井ビル

3.3.3 *Notice for EVMs for Power Line Communication:* Please see http://www.tij.co.jp/llds/ti_ja/general/eStore/notice_02.page

電力線搬送波通信についての開発キットをお使いになる際の注意事項については、次のところをご覧ください。http://www.tij.co.jp/llds/ti_ja/general/eStore/notice_02.page

4 *EVM Use Restrictions and Warnings:*

4.1 EVMS ARE NOT FOR USE IN FUNCTIONAL SAFETY AND/OR SAFETY CRITICAL EVALUATIONS, INCLUDING BUT NOT LIMITED TO EVALUATIONS OF LIFE SUPPORT APPLICATIONS.

4.2 User must read and apply the user guide and other available documentation provided by TI regarding the EVM prior to handling or using the EVM, including without limitation any warning or restriction notices. The notices contain important safety information related to, for example, temperatures and voltages.

4.3 *Safety-Related Warnings and Restrictions:*

4.3.1 User shall operate the EVM within TI's recommended specifications and environmental considerations stated in the user guide, other available documentation provided by TI, and any other applicable requirements and employ reasonable and customary safeguards. Exceeding the specified performance ratings and specifications (including but not limited to input and output voltage, current, power, and environmental ranges) for the EVM may cause personal injury or death, or property damage. If there are questions concerning performance ratings and specifications, User should contact a TI field representative prior to connecting interface electronics including input power and intended loads. Any loads applied outside of the specified output range may also result in unintended and/or inaccurate operation and/or possible permanent damage to the EVM and/or interface electronics. Please consult the EVM user guide prior to connecting any load to the EVM output. If there is uncertainty as to the load specification, please contact a TI field representative. During normal operation, even with the inputs and outputs kept within the specified allowable ranges, some circuit components may have elevated case temperatures. These components include but are not limited to linear regulators, switching transistors, pass transistors, current sense resistors, and heat sinks, which can be identified using the information in the associated documentation. When working with the EVM, please be aware that the EVM may become very warm.

4.3.2 EVMs are intended solely for use by technically qualified, professional electronics experts who are familiar with the dangers and application risks associated with handling electrical mechanical components, systems, and subsystems. User assumes all responsibility and liability for proper and safe handling and use of the EVM by User or its employees, affiliates, contractors or designees. User assumes all responsibility and liability to ensure that any interfaces (electronic and/or mechanical) between the EVM and any human body are designed with suitable isolation and means to safely limit accessible leakage currents to minimize the risk of electrical shock hazard. User assumes all responsibility and liability for any improper or unsafe handling or use of the EVM by User or its employees, affiliates, contractors or designees.

4.4 User assumes all responsibility and liability to determine whether the EVM is subject to any applicable international, federal, state, or local laws and regulations related to User's handling and use of the EVM and, if applicable, User assumes all responsibility and liability for compliance in all respects with such laws and regulations. User assumes all responsibility and liability for proper disposal and recycling of the EVM consistent with all applicable international, federal, state, and local requirements.

5. *Accuracy of Information:* To the extent TI provides information on the availability and function of EVMs, TI attempts to be as accurate as possible. However, TI does not warrant the accuracy of EVM descriptions, EVM availability or other information on its websites as accurate, complete, reliable, current, or error-free.

6. *Disclaimers:*
- 6.1 EXCEPT AS SET FORTH ABOVE, EVMS AND ANY WRITTEN DESIGN MATERIALS PROVIDED WITH THE EVM (AND THE DESIGN OF THE EVM ITSELF) ARE PROVIDED "AS IS" AND "WITH ALL FAULTS." TI DISCLAIMS ALL OTHER WARRANTIES, EXPRESS OR IMPLIED, REGARDING SUCH ITEMS, INCLUDING BUT NOT LIMITED TO ANY IMPLIED WARRANTIES OF MERCHANTABILITY OR FITNESS FOR A PARTICULAR PURPOSE OR NON-INFRINGEMENT OF ANY THIRD PARTY PATENTS, COPYRIGHTS, TRADE SECRETS OR OTHER INTELLECTUAL PROPERTY RIGHTS.
 - 6.2 EXCEPT FOR THE LIMITED RIGHT TO USE THE EVM SET FORTH HEREIN, NOTHING IN THESE TERMS AND CONDITIONS SHALL BE CONSTRUED AS GRANTING OR CONFERRING ANY RIGHTS BY LICENSE, PATENT, OR ANY OTHER INDUSTRIAL OR INTELLECTUAL PROPERTY RIGHT OF TI, ITS SUPPLIERS/LICENSORS OR ANY OTHER THIRD PARTY, TO USE THE EVM IN ANY FINISHED END-USER OR READY-TO-USE FINAL PRODUCT, OR FOR ANY INVENTION, DISCOVERY OR IMPROVEMENT MADE, CONCEIVED OR ACQUIRED PRIOR TO OR AFTER DELIVERY OF THE EVM.
7. *USER'S INDEMNITY OBLIGATIONS AND REPRESENTATIONS.* USER WILL DEFEND, INDEMNIFY AND HOLD TI, ITS LICENSORS AND THEIR REPRESENTATIVES HARMLESS FROM AND AGAINST ANY AND ALL CLAIMS, DAMAGES, LOSSES, EXPENSES, COSTS AND LIABILITIES (COLLECTIVELY, "CLAIMS") ARISING OUT OF OR IN CONNECTION WITH ANY HANDLING OR USE OF THE EVM THAT IS NOT IN ACCORDANCE WITH THESE TERMS AND CONDITIONS. THIS OBLIGATION SHALL APPLY WHETHER CLAIMS ARISE UNDER STATUTE, REGULATION, OR THE LAW OF TORT, CONTRACT OR ANY OTHER LEGAL THEORY, AND EVEN IF THE EVM FAILS TO PERFORM AS DESCRIBED OR EXPECTED.
8. *Limitations on Damages and Liability:*
- 8.1 *General Limitations.* IN NO EVENT SHALL TI BE LIABLE FOR ANY SPECIAL, COLLATERAL, INDIRECT, PUNITIVE, INCIDENTAL, CONSEQUENTIAL, OR EXEMPLARY DAMAGES IN CONNECTION WITH OR ARISING OUT OF THESE TERMS AND CONDITIONS OR THE USE OF THE EVMS PROVIDED HEREUNDER, REGARDLESS OF WHETHER TI HAS BEEN ADVISED OF THE POSSIBILITY OF SUCH DAMAGES. EXCLUDED DAMAGES INCLUDE, BUT ARE NOT LIMITED TO, COST OF REMOVAL OR REINSTALLATION, ANCILLARY COSTS TO THE PROCUREMENT OF SUBSTITUTE GOODS OR SERVICES, RETESTING, OUTSIDE COMPUTER TIME, LABOR COSTS, LOSS OF GOODWILL, LOSS OF PROFITS, LOSS OF SAVINGS, LOSS OF USE, LOSS OF DATA, OR BUSINESS INTERRUPTION. NO CLAIM, SUIT OR ACTION SHALL BE BROUGHT AGAINST TI MORE THAN ONE YEAR AFTER THE RELATED CAUSE OF ACTION HAS OCCURRED.
 - 8.2 *Specific Limitations.* IN NO EVENT SHALL TI'S AGGREGATE LIABILITY FROM ANY WARRANTY OR OTHER OBLIGATION ARISING OUT OF OR IN CONNECTION WITH THESE TERMS AND CONDITIONS, OR ANY USE OF ANY TI EVM PROVIDED HEREUNDER, EXCEED THE TOTAL AMOUNT PAID TO TI FOR THE PARTICULAR UNITS SOLD UNDER THESE TERMS AND CONDITIONS WITH RESPECT TO WHICH LOSSES OR DAMAGES ARE CLAIMED. THE EXISTENCE OF MORE THAN ONE CLAIM AGAINST THE PARTICULAR UNITS SOLD TO USER UNDER THESE TERMS AND CONDITIONS SHALL NOT ENLARGE OR EXTEND THIS LIMIT.
9. *Return Policy.* Except as otherwise provided, TI does not offer any refunds, returns, or exchanges. Furthermore, no return of EVM(s) will be accepted if the package has been opened and no return of the EVM(s) will be accepted if they are damaged or otherwise not in a resalable condition. If User feels it has been incorrectly charged for the EVM(s) it ordered or that delivery violates the applicable order, User should contact TI. All refunds will be made in full within thirty (30) working days from the return of the components(s), excluding any postage or packaging costs.
10. *Governing Law:* These terms and conditions shall be governed by and interpreted in accordance with the laws of the State of Texas, without reference to conflict-of-laws principles. User agrees that non-exclusive jurisdiction for any dispute arising out of or relating to these terms and conditions lies within courts located in the State of Texas and consents to venue in Dallas County, Texas. Notwithstanding the foregoing, any judgment may be enforced in any United States or foreign court, and TI may seek injunctive relief in any United States or foreign court.

Mailing Address: Texas Instruments, Post Office Box 655303, Dallas, Texas 75265
Copyright © 2015, Texas Instruments Incorporated

IMPORTANT NOTICE

Texas Instruments Incorporated and its subsidiaries (TI) reserve the right to make corrections, enhancements, improvements and other changes to its semiconductor products and services per JESD46, latest issue, and to discontinue any product or service per JESD48, latest issue. Buyers should obtain the latest relevant information before placing orders and should verify that such information is current and complete. All semiconductor products (also referred to herein as "components") are sold subject to TI's terms and conditions of sale supplied at the time of order acknowledgment.

TI warrants performance of its components to the specifications applicable at the time of sale, in accordance with the warranty in TI's terms and conditions of sale of semiconductor products. Testing and other quality control techniques are used to the extent TI deems necessary to support this warranty. Except where mandated by applicable law, testing of all parameters of each component is not necessarily performed.

TI assumes no liability for applications assistance or the design of Buyers' products. Buyers are responsible for their products and applications using TI components. To minimize the risks associated with Buyers' products and applications, Buyers should provide adequate design and operating safeguards.

TI does not warrant or represent that any license, either express or implied, is granted under any patent right, copyright, mask work right, or other intellectual property right relating to any combination, machine, or process in which TI components or services are used. Information published by TI regarding third-party products or services does not constitute a license to use such products or services or a warranty or endorsement thereof. Use of such information may require a license from a third party under the patents or other intellectual property of the third party, or a license from TI under the patents or other intellectual property of TI.

Reproduction of significant portions of TI information in TI data books or data sheets is permissible only if reproduction is without alteration and is accompanied by all associated warranties, conditions, limitations, and notices. TI is not responsible or liable for such altered documentation. Information of third parties may be subject to additional restrictions.

Resale of TI components or services with statements different from or beyond the parameters stated by TI for that component or service voids all express and any implied warranties for the associated TI component or service and is an unfair and deceptive business practice. TI is not responsible or liable for any such statements.

Buyer acknowledges and agrees that it is solely responsible for compliance with all legal, regulatory and safety-related requirements concerning its products, and any use of TI components in its applications, notwithstanding any applications-related information or support that may be provided by TI. Buyer represents and agrees that it has all the necessary expertise to create and implement safeguards which anticipate dangerous consequences of failures, monitor failures and their consequences, lessen the likelihood of failures that might cause harm and take appropriate remedial actions. Buyer will fully indemnify TI and its representatives against any damages arising out of the use of any TI components in safety-critical applications.

In some cases, TI components may be promoted specifically to facilitate safety-related applications. With such components, TI's goal is to help enable customers to design and create their own end-product solutions that meet applicable functional safety standards and requirements. Nonetheless, such components are subject to these terms.

No TI components are authorized for use in FDA Class III (or similar life-critical medical equipment) unless authorized officers of the parties have executed a special agreement specifically governing such use.

Only those TI components which TI has specifically designated as military grade or "enhanced plastic" are designed and intended for use in military/aerospace applications or environments. Buyer acknowledges and agrees that any military or aerospace use of TI components which have **not** been so designated is solely at the Buyer's risk, and that Buyer is solely responsible for compliance with all legal and regulatory requirements in connection with such use.

TI has specifically designated certain components as meeting ISO/TS16949 requirements, mainly for automotive use. In any case of use of non-designated products, TI will not be responsible for any failure to meet ISO/TS16949.

Products

Audio	www.ti.com/audio
Amplifiers	amplifier.ti.com
Data Converters	dataconverter.ti.com
DLP® Products	www.dlp.com
DSP	dsp.ti.com
Clocks and Timers	www.ti.com/clocks
Interface	interface.ti.com
Logic	logic.ti.com
Power Mgmt	power.ti.com
Microcontrollers	microcontroller.ti.com
RFID	www.ti-rfid.com
OMAP Applications Processors	www.ti.com/omap
Wireless Connectivity	www.ti.com/wirelessconnectivity

Applications

Automotive and Transportation	www.ti.com/automotive
Communications and Telecom	www.ti.com/communications
Computers and Peripherals	www.ti.com/computers
Consumer Electronics	www.ti.com/consumer-apps
Energy and Lighting	www.ti.com/energy
Industrial	www.ti.com/industrial
Medical	www.ti.com/medical
Security	www.ti.com/security
Space, Avionics and Defense	www.ti.com/space-avionics-defense
Video and Imaging	www.ti.com/video

TI E2E Community

e2e.ti.com