

# Infrared Emitter

## MTE8080P

### Applications -

- Linear and Rotary Encoder
- Optical Switch

### Features -

- High Output Power
- Optical Grade Glass Lens
- Precise Optical/Mechanical Axis Alignment
- Narrow Beam Pattern

### MAXIMUM RATINGS (Ta = 25°C)

CHARACTERISTIC	SYMBOL	RATING	UNIT
Forward Current	$I_F$	100	mA
Pulse Forward Current	$I_{FP}$	1.0*	A
Reverse Voltage	$V_R$	5	V
Power Dissipation	$P_D$	180	mW
Operating Temperature	$T_{opr}$	-20~100	°C
Storage Temperature	$T_{stg}$	-30~100	°C
Junction Temperature	$T_j$	100	°C

\* tw = 10μs, T = 10ms

### OPTO-ELECTRICAL CHARACTERISTICS (Ta = 25°C)

CHARACTERISTIC	SYMBOL	TEST CONDITION	MIN.	TYP.	MAX.	UNIT
Power Output	PO	IF = 50mA	—	5.0	—	mW
Forward Voltage	$V_F$	IF = 50mA	—	1.45	1.7	V
Reverse Current	$I_R$	VR = 5V	—	—	10	μA
Peak Wavelength	$\lambda_p$	IF = 20mA	—	880	—	nm
Spectral Line Half Width	$\Delta\lambda$	IF = 20mA	—	60	—	nm
Rise Time	$T_r$	—	—	1500	—	ns
Fall Time	$T_f$	—	—	800	—	ns
Beam Angle	$\theta$	—	—	±5	—	°
Temperature Coefficient of PO	TC of PO	IF = 10mA	—	-0.5	—	% / °C
Temperature Coefficient of VF	TC of VF	IF = 10mA	—	-1.5	—	mV / °C
Junction Capacitance	$C_j$	1MHz, V = 0V	—	15	—	pF

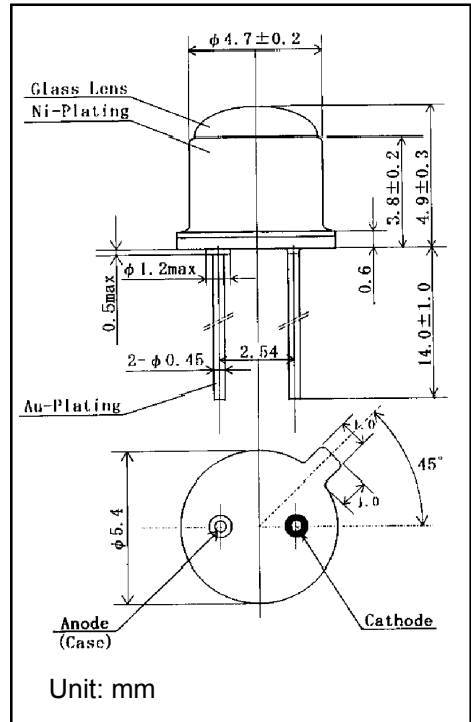

**marktech**  
**optoelectronics**

120 Broadway • Menands, New York 12204

Toll Free: (800) 98-4LEDS • Fax: (518) 432-7454

# Infrared Emitter

## MTE8080P Graphs -

