

TO
Q

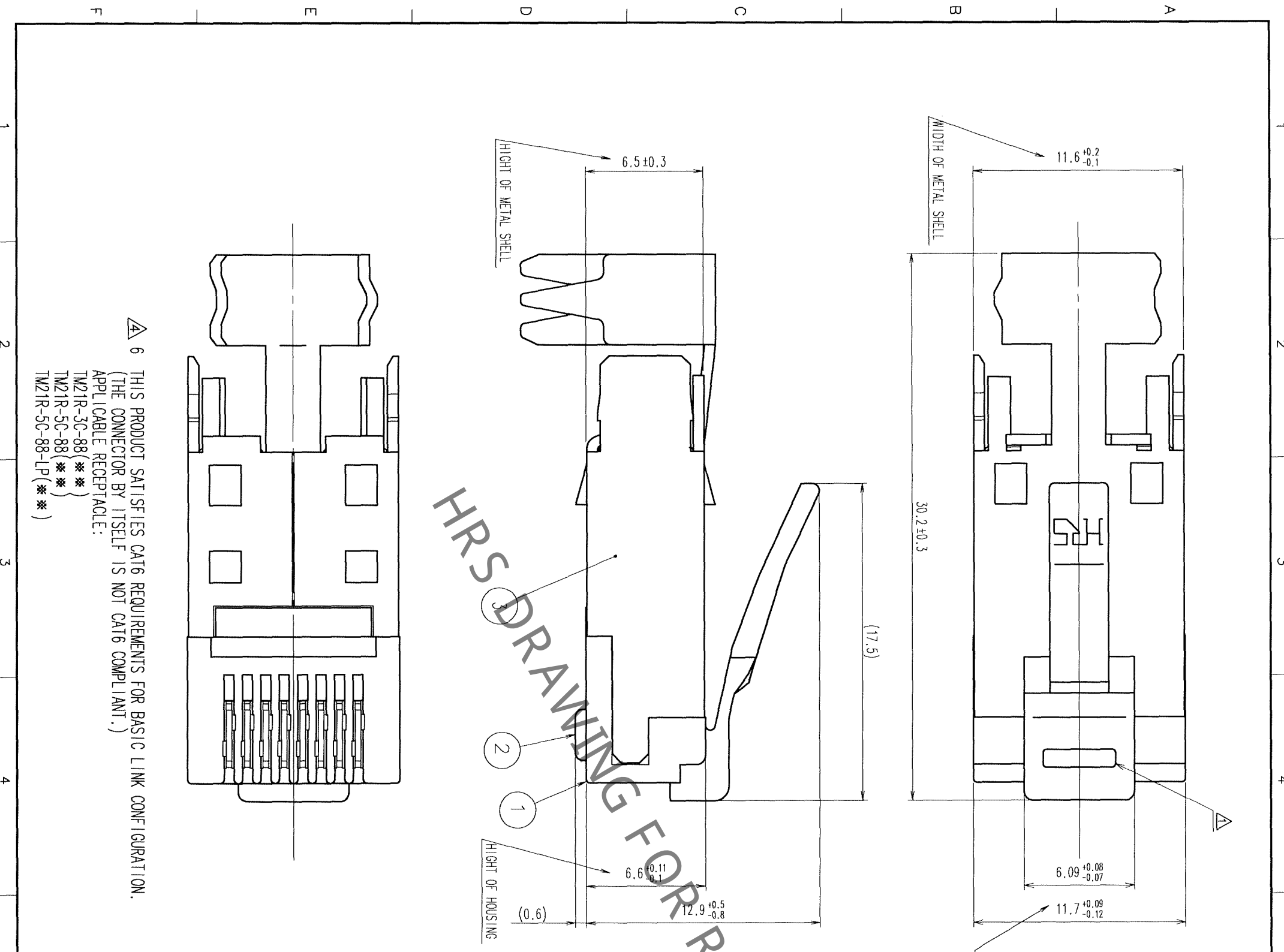

COUNT	DESCRIPTION OF REVISIONS	BY	CHKD	DATE	COUNT	DESCRIPTION OF REVISIONS	BY	CHKD	DATE
1	RE-E-07734	S.S	T.W	01.03.15	1	REWRITTEN BY CAD	Y.S	K.E	06.09.01
2	RE-E-08257	K.H	T.W	01.12.21	1	DIS-E-000934	Y.S	K.E	06.09.01
3	RE-E-09963	S.S	T.W	04.05.31					

TABLE-1

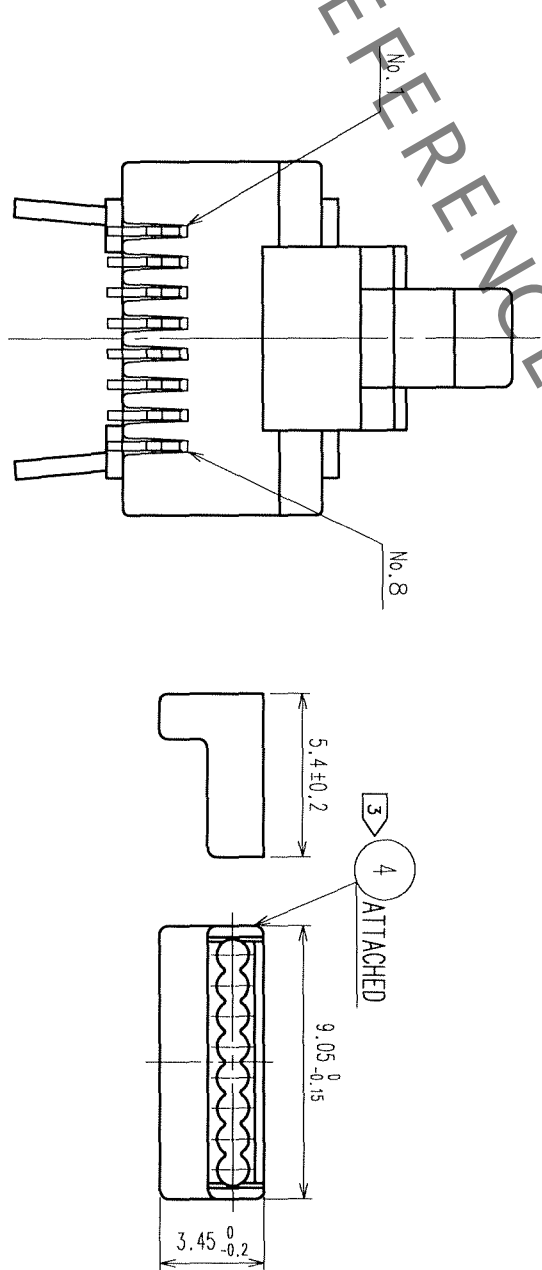
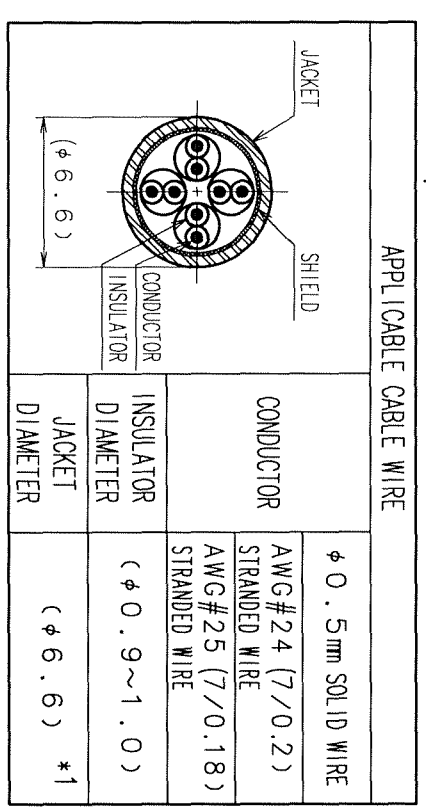

NOTES 1 ( ) INDICATES THE REFERENCE DIMENSIONS.

- 2 APPLICABLE CABLE IS SHOWN IN TABLE-1
- \* 1 : THE OUTER DIAMETER OF THE VINYL JACKET VARIES SLIGHTLY DEPENDING ON THE HARDNESS:6.6D/A. IS FOR REFERENCE.
- 3 PLEASE USE ACCESSORY AS A GUIDE PLATE AND ASSEMBLE CONNECTOR WITH CABLES INSERTING ACCESSORY INTO CONNECTER.
- 4 HOOD COLORS ARE SHOWN IN TABLE-2.
- 5 TO SATISFY CAT5e PERFORMANCE, PLEASE ASSEMBLE ACCORDING TO HRS INSTRUCTION.

NO.	MATERIAL	FINISH, REMARKS	NO.	MATERIAL	FINISH, REMARKS
3	BRASS	TIN PLATING	5	POLYAMIDE	
2	PHOSPHOR BRONZE	GOLD PLATING 1.27μm	4	POLYCARBONATE	(CLEAR)
1	POLYCARBONATE	(CLEAR)			

6 THIS PRODUCT SATISFIES CAT6 REQUIREMENTS FOR BASIC LINK CONFIGURATION. (THE CONNECTOR BY ITSELF IS NOT CAT6 COMPLIANT.)  
 APPLICABLE RECEPTACLE:  
 TM21R-3C-88(\*\*\*)  
 TM21R-5C-88(\*\*\*)  
 TM21R-5C-88-LP(\*\*\*)

SCALE	4 : 1	DRAWING NO.	EDC3-121484-04	PART NO.	TM21P-88P J
UNITS	mm	CODE NO.	CL222-2862-9-r J		
		HRS HIROSE ELECTRIC CO., LTD		1/2	

TO
Q2

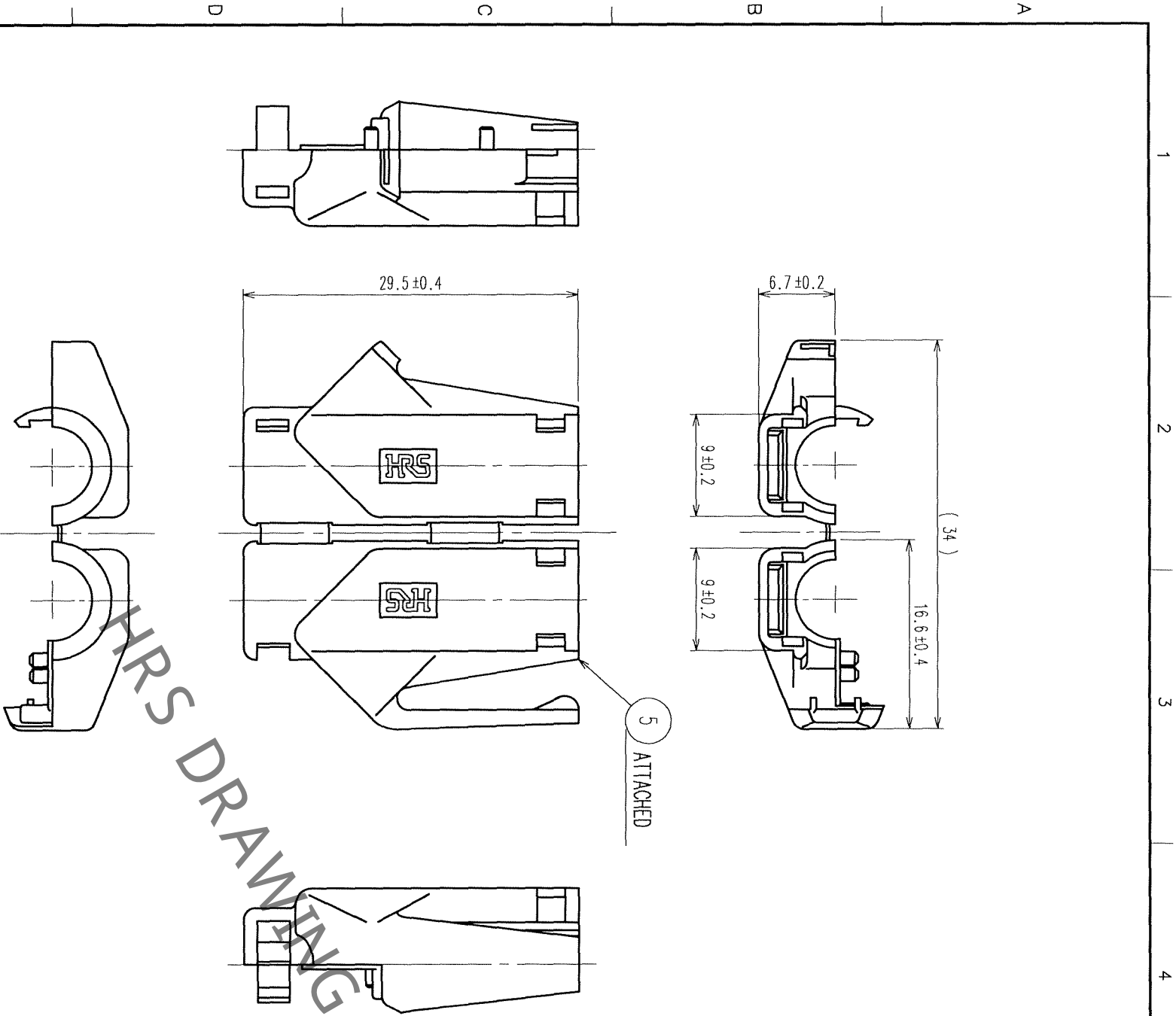

COUNT	DESCRIPTION OF REVISIONS	BY	CHKD	DATE	COUNT	DESCRIPTION OF REVISIONS	BY	CHKD	DATE

4 TABLE-2

PART NO.	HRS NO.	COLOR
TM21P-88P	CL222-2862-9	LIGHT BEIGE
TM21P-88P(02)	CL222-2862-9(02)	MEDIUM GRAY
TM21P-88P(03)	CL222-2862-9(03)	BLACK
TM21P-88P(04)	CL222-2862-9(04)	NATURAL LIGHT GRAY
TM21P-88P(05)	CL222-2862-9(05)	RED
TM21P-88P(06)	CL222-2862-9(06)	GREEN
TM21P-88P(07)	CL222-2862-9(07)	BLUE
TM21P-88P(08)	CL222-2862-9(08)	YELLOW
TM21P-88P(09)	CL222-2862-9(09)	ORANGE

HOOD ATTACHMENT PROCEDURE  
(FREE)

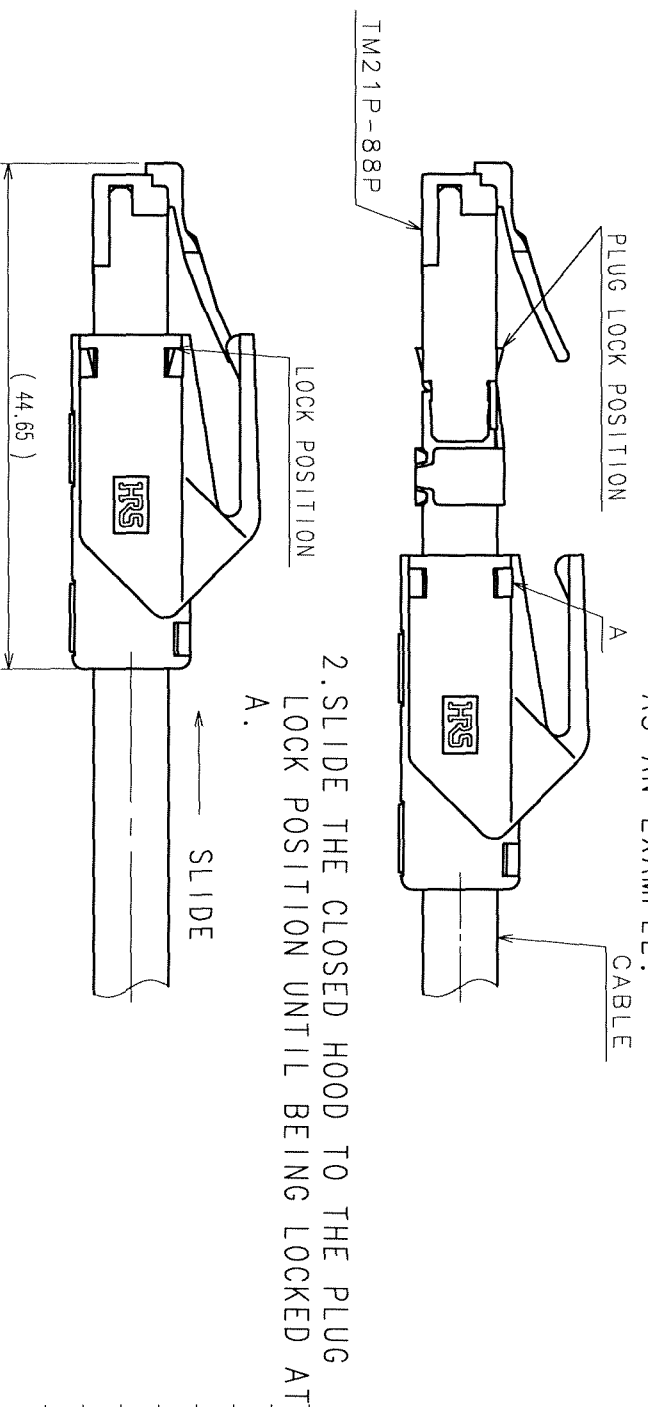

1. FIT THE OPENED HOOD ON THE CABLE AND CLOSE. HOOD DIRECTION IS SHOWN AS AN EXAMPLE.

2. SLIDE THE CLOSED HOOD TO THE PLUG LOCK POSITION UNTIL BEING LOCKED AT A.

NO.	MATERIAL	FINISH, REMARKS	NO.	MATERIAL	FINISH, REMARKS

NO.	DESIGNED	CHECKED	APPROVED	RELEASED
	S. SATO	T. WATANABE	H. MIWA	

DRAWING NO.	PART NO.
EDC3-121484-04	TM21P-88P r j

SCALE	2 : 1
UNITS	MM

<b>HRS</b>	HIROSE ELECTRIC CO., LTD.
------------	---------------------------

CODE NO.	CL222-2862-9-r j
----------	------------------