

NUMBER GS-20-0513	TYPE Application Specification		
TITLE <b>MINITEK MicroSpace™ connector</b>		PAGE 1 of 10	REVISION H
		AUTHORIZED BY VALLIERE Jérôme	DATE 05/06/2023
CLASSIFICATION <b>UNRESTRICTED</b>			

## 1.0 OBJECTIVE

This specification provides information and requirements regarding customer application of Minitek MicroSpace™ connectors. This specification is intended to provide general guidance for application process development. It is recognized that no single application process will work under all customer scenarios and that customers will develop their own application processes to meet their needs. However, if these application processes differ greatly from the one recommended, AFCI cannot guarantee results.

## 2.0 SCOPE

This specification provides information and requirements regarding customer application of Minitek MicroSpace™ connector.

## 3.0 GENERAL

This document is meant to be an application guide. If there is a conflict between the product drawings and specifications, the drawings take precedence.

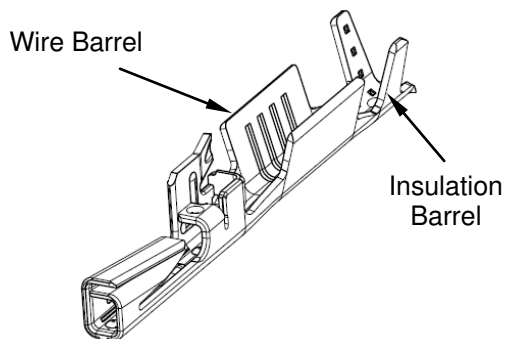

Receptacle Terminal 10141272 & 10148496 series

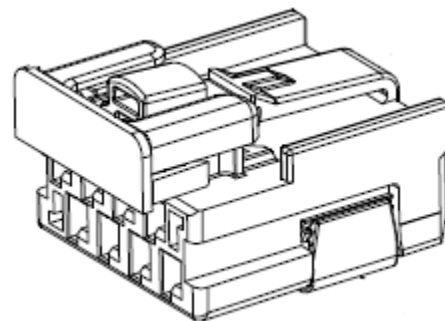

Receptacle Assembly

## 4.0 DRAWINGS AND APPLICABLE DOCUMENTS

- AFCI PRODUCT SPECIFICATION GS-12-1422
- AFCI PRODUCT DRAWINGS
- APPLICATION MANUALS/INSTRUCTION SHEETS (IF NOT INCLUDED IN THIS DOCUMENT)

Product drawings and **AFCI's GS-12-1422** Product Specification are available at [www.fci.com](http://www.fci.com). In the event of a conflict between this application specification and the drawing, the drawing will take precedence. Customers are advised to refer to the latest revision level of AFCI product drawings for appropriate details.

NUMBER GS-20-0513	TYPE <b>Application Specification</b>		
TITLE <b>MINITEK MicroSpace™ connector</b>		PAGE 2 of 10	REVISION H
		AUTHORIZED BY VALLIERE Jérôme	DATE 05/06/2023
		CLASSIFICATION <b>UNRESTRICTED</b>	

## 5.0 APPLICATION REQUIREMENTS

The wires in Table (1) are qualified for use with Receptacle Terminal 10141272 & 10148496.

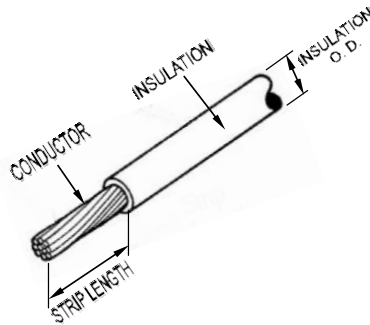



Table (1)

Wire Manufacturers PN	#of Conductors	AWG	Solid -or- Stranded	# of Strands Insulation	Insulation Material	Insulation Diameter	Strip Length
-	7	AWG22	Stranded	-	TPE-E	1.4mm max	4mm
-	7	AWG24	Stranded	-	TPE-E	1.4mm max	
-	7	AWG26	Stranded	-	TPE-E	1.1mm max	
-	7	AWG28	Stranded	-	TPE-E	0.9mm max	

## 6.0 AUTOMATIC APPLICATION TOOLING

Automatic Application Tooling needed for installation of Receptacle Terminal 10141272 & 10148496 is defined in Table (2):

Table (2)

TOOL SUPPLIER	DESIGNATION	TOOL P/N	PHOTO FOR INFORMATION ONLY
AMPHENOL FILEC rfq@filec.fr	Mini applicator Minitек μSpace AWG22 10141272-Y11LF & 10148496-Y11LF	T1002-22	
	Mini applicator Minitек μSpace AWG24 10141272-Y13LF & 10148496-Y13LF	T1001-24	
	Mini applicator Minitек μSpace AWG26 10141272-Y12LF & 10148496-Y12LF	T1003-26	
	Mini applicator Minitек μSpace AWG28 10141272-Y12LF & 10148496-Y12LF	T1004-28	
	Spare parts for mini applicator Minitек μSpace AWG22 10141272-Y11LF & 10148496-Y11LF	T2002-22	
	Spare parts for mini applicator Minitек μSpace AWG24 10141272-Y13LF & 10148496-Y13LF	T2001-24	
	Spare parts for mini applicator Minitек μSpace AWG26 10141272-Y12LF & 10148496-Y12LF	T2003-26	
	Spare parts for mini applicator Minitек μSpace AWG28 10141272-Y12LF & 10148496-Y12LF	T2004-28	

NUMBER GS-20-0513	TYPE <b>Application Specification</b>		
TITLE <b>MINITEK MicroSpace™ connector</b>		PAGE 3 of 10	REVISION H
		AUTHORIZED BY VALLIERE Jérôme	DATE 05/06/2023
CLASSIFICATION <b>UNRESTRICTED</b>			

## TOOL INSPECTION / MAINTENANCE

It is recommended that each tool be inspected upon its arrival to be sure it has not been damaged in transit, and at regularly scheduled intervals to be sure it remains functional.

Lubrication should be used on the stamping dies to assure optimal crimping.

Recommended lubricant: *Fuchs Renoform TD 2010*

For a good quality and stability of the crimping, we recommend to maintain the tool regularly and to change the spare parts every 200 Kpcs.

## 7.0 MANUAL APPLICATION TOOLING

Manual Application Tooling needed for installation of Receptacle Terminal 10141272 & 10148496 is defined in Table (3):

Table (3)

<u>TOOL SUPPLIER</u>	<u>DESIGNATION</u>	<u>TOOL P/N</u>	<u>PHOTO FOR INFORMATION ONLY</u>
<b>Contact us to have the partner's list for the tools in stock</b>	<b>Crimping hand tool Minitex μSpace</b>	<b>10161117-001</b>	
	<b>AWG22 - 10141272-Y11LF &amp; 10148496-Y11LF</b>		
	<b>AWG24 - 10141272-Y13LF &amp; 10148496-Y13LF</b>		
	<b>AWG26 - 10141272-Y12LF &amp; 10148496-Y12LF</b>		
	<b>AWG28 - 10141272-Y12LF &amp; 10148496-Y12LF</b>		

The crimp made by using the hand tool is not recommended to production or qualification use.

## 8.0 APPLICATION PROCEDURE

- 8.1 Strip the wire (Table 1).
- 8.2 Crimp the wire (Table 2, 3, 4, 5).
- 8.3 Insert the wire into the receptacle housing.
- 8.4 Close the TPA.

NUMBER GS-20-0513	TYPE Application Specification		
TITLE <b>MINITEK MicroSpace™ connector</b>		PAGE 4 of 10	REVISION H
		AUTHORIZED BY VALLIERE Jérôme	DATE 05/06/2023
CLASSIFICATION <b>UNRESTRICTED</b>			

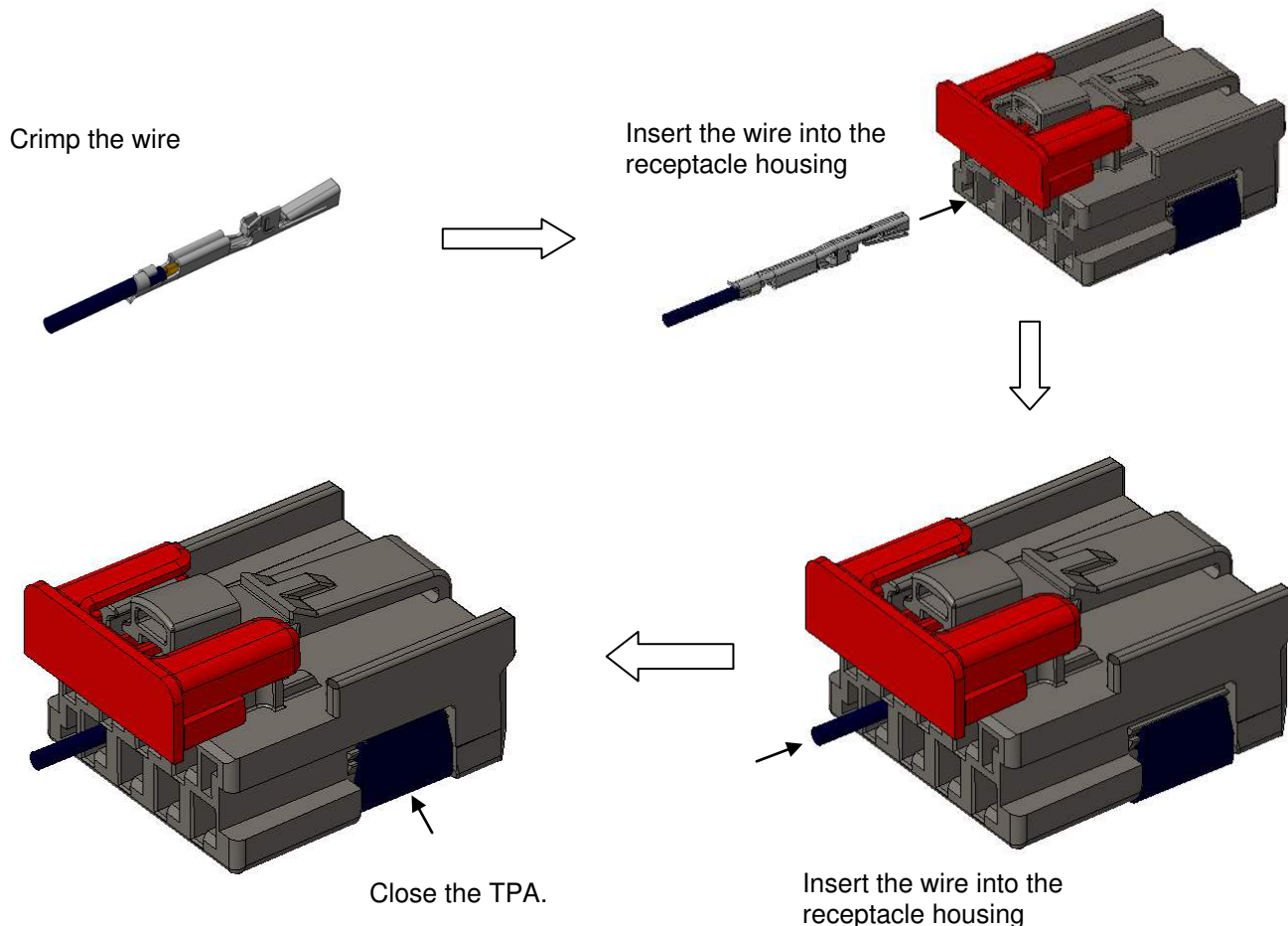

Make sure the Receptacle terminal is well oriented for the insertion to the housing.

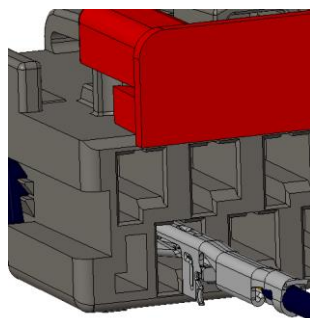

NUMBER GS-20-0513	TYPE <b>Application Specification</b>		
TITLE <b>MINITEK MicroSpace™ connector</b>		PAGE 5 of 10	REVISION H
		AUTHORIZED BY VALLIERE Jérôme	DATE 05/06/2023
		CLASSIFICATION <b>UNRESTRICTED</b>	

Insert the terminal into HSG until the front is stopped by HSG. Then locking tab will be engaged the retention shoulder and prevent back out during mating. Pull back on the wire lightly and ensure the terminal is fully seated.

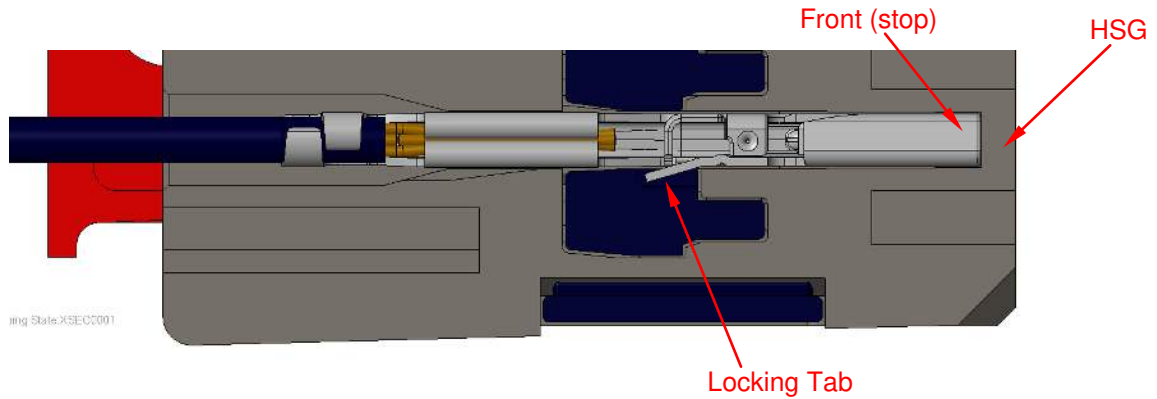

## 9.0 POST-APPLICATION INSPECTION PROCEDURES

### 9.1 Crimp height and width measurement:

9.1.1 Use Crimp Height Type Micrometers to measure crimping height.

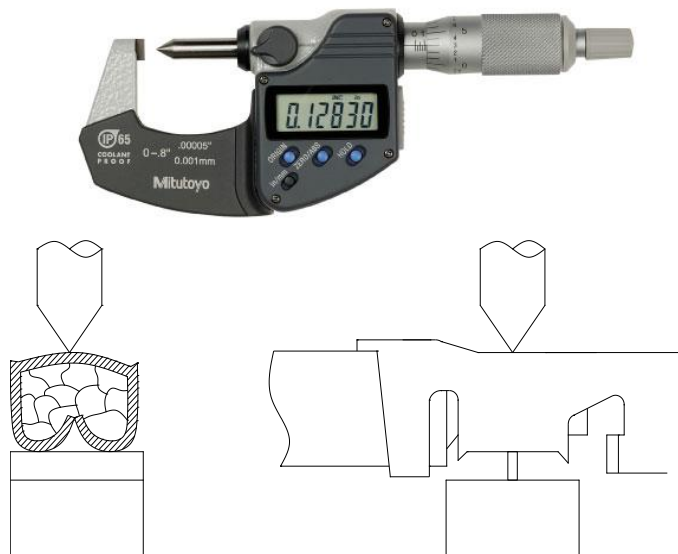

NUMBER GS-20-0513	TYPE <b>Application Specification</b>		
TITLE <b>MINITEK MicroSpace™ connector</b>		PAGE 6 of 10	REVISION H
		AUTHORIZED BY VALLIERE Jérôme	DATE 05/06/2023
		CLASSIFICATION <b>UNRESTRICTED</b>	

9.2 Required crimping dimensions, crimp height and width for different wire AWG are defined in Table (4) & Table (5).

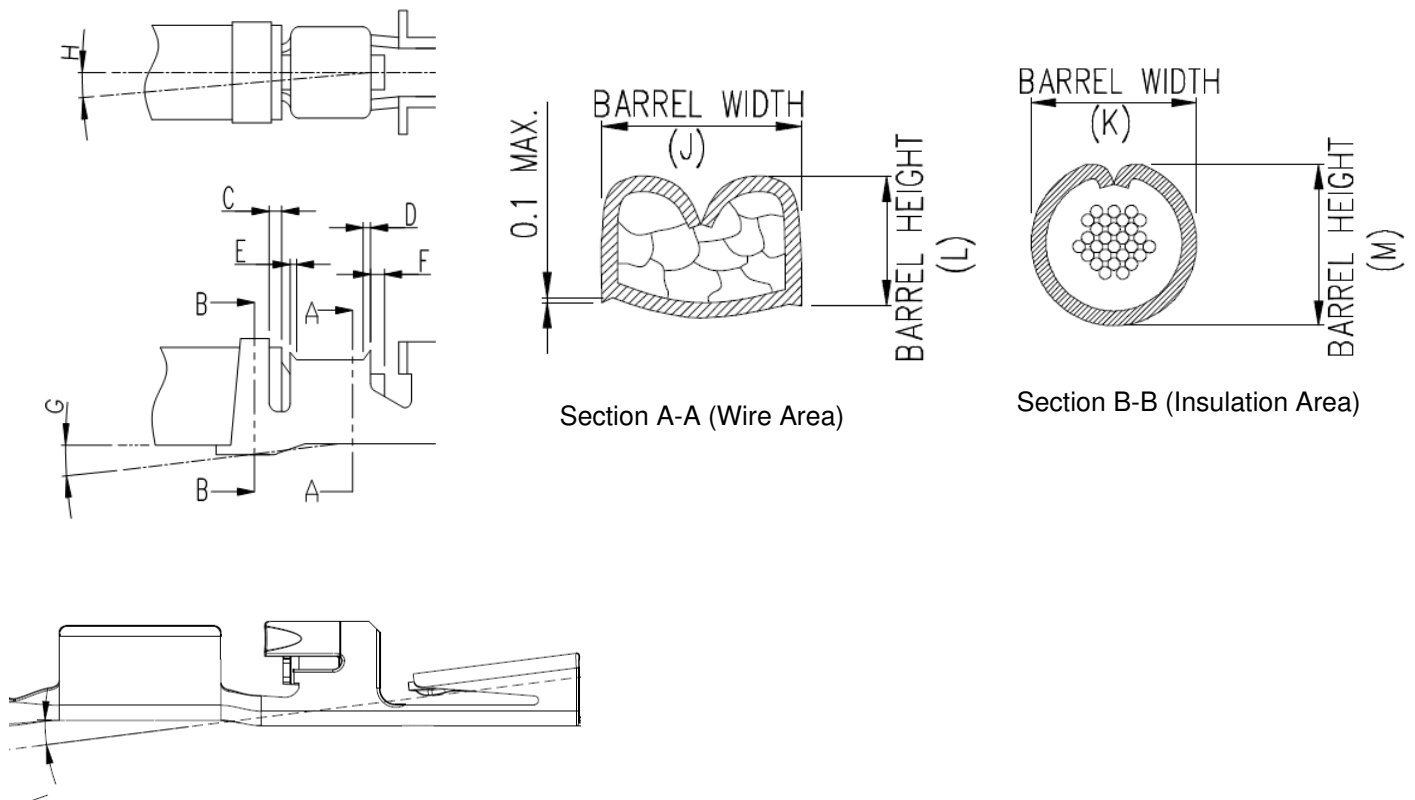

Table (4) (unit: mm)

Item		Requirement	Note
Insulation position	C	0.5 mm	Insulation and wire should be both visual in this area
Front bell mouth	D	-	Not required
Rear bell mouth	E	0.2 - 0.5mm	
Extruded wire length	F	0.5mm max.	
Bend up / down	G	±3° max.	
Bend right / left	H	±3° max.	
Bend up / down (shaft)	I	±1.5° max.	Max. angle between the crimping area and the connecting area

NUMBER GS-20-0513	TYPE Application Specification		
TITLE MINITEK MicroSpace™ connector		PAGE 7 of 10	REVISION H
		AUTHORIZED BY VALLIERE Jérôme	DATE 05/06/2023
CLASSIFICATION UNRESTRICTED			

Table (5) (unit: mm)

Crimping Width & Height (mm)		AWG 22	AWG 24	AWG 26	AWG 28
Crimping Width (Wire barrel)	J	1.1 <sup>0/-0.05</sup>	1.1 <sup>0/-0.05</sup>	0.9 <sup>0/-0.05</sup>	0.9 <sup>0/-0.05</sup>
Crimping Width (Insulation barrel)	K	1.35 <sup>0/-0.1</sup>	1.35 <sup>0/-0.1</sup>	1.05 <sup>0/-0.1</sup>	0.95 <sup>0/-0.1</sup>
Crimping Height (Wire barrel)	L	0.74 <sup>+/-0.03 (*)</sup>	0.62 <sup>+/-0.03</sup>	0.56 <sup>+/-0.03</sup>	0.54 <sup>+/-0.03</sup>
Crimping Height (Insulation barrel)	M	1.45 <sup>0/-0.1</sup>	1.35 <sup>0/-0.1</sup>	1.2 <sup>0/-0.1</sup>	1 <sup>0/-0.1</sup>

(\*) With the Handtool P/N 10161117-001 the dimension is 0.78 +/- 0.03.

### 9.3 Pullout force measurement

- 9.3.1 After crimping, pullout force measurement should be applied to ensure the performance.
- 9.3.2 Apply an axial pullout force on the wire at a rate of 25 ± 6 mm.
- 9.3.3 Pullout force should not be less the those listed in Table (6) and Table (7).

Table (6) (unit: N) Only for Automatic Crimping

Wire AWG	AWG 22	AWG 24	AWG 26	AWG 28
Wire Pullout Force	50N min	35N min	25N min	15Nmin

Table (7) (unit: N) Only for Handtool Crimping

Wire AWG	AWG 22	AWG 24	AWG 26	AWG 28
Wire Pullout Force	50N min	28N min	15N min	11N min

### 9.4 Visual Inspection:

- 9.4.1 No damage, deformation on locking tabs, contact area or other portion of the terminals.
- 9.4.2 Insulation should not be crimped into wire barrel.
- 9.4.3 Wire should not be cut-off and insulation should not be broken after crimping process.

### 9.5 Required width dimensions:

- 9.5.1 Width dimensions should be applied to ensure the good insertion of the terminal into the housing.
- 9.5.2 During the crimp operation, the front transition area should be managed to respect the crimping widths (J) all along the wire barrel area.
- 9.5.3 During the crimp operation, the rear transition area should be managed to respect the crimping widths (K) all along the insulation barrel area.

NUMBER GS-20-0513	TYPE Application Specification		
TITLE <b>MINITEK MicroSpace™ connector</b>		PAGE 8 of 10	REVISION H
		AUTHORIZED BY VALLIERE Jérôme	DATE 05/06/2023
		CLASSIFICATION <b>UNRESTRICTED</b>	

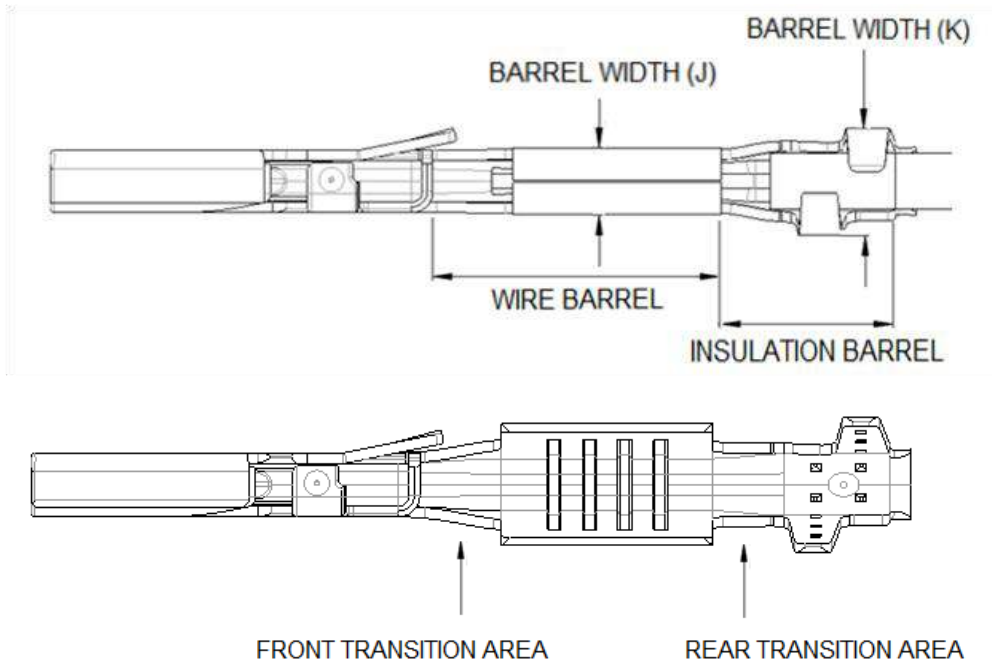

## 9.6 Maximum burr

9.6.1 When detaching the CTW from its reel, burrs should be kept at a minimum.

9.6.2 The maximal burr admissible at the connecting end of the CTW should be less than 0.1mm in length.

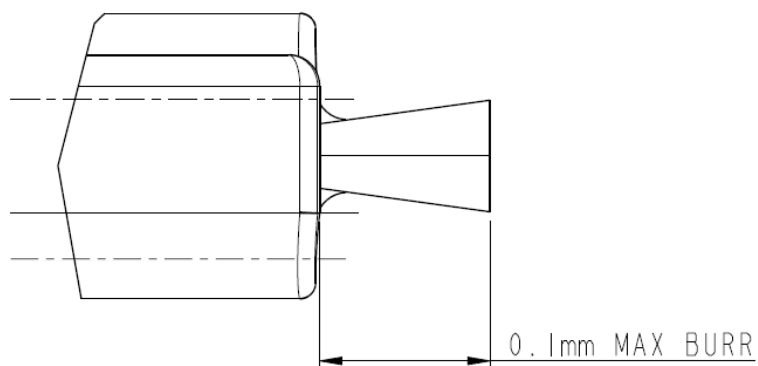



NUMBER GS-20-0513	TYPE Application Specification		
TITLE MINITEK MicroSpace™ connector		PAGE 9 of 10	REVISION H
		AUTHORIZED BY VALLIERE Jérôme	DATE 05/06/2023
CLASSIFICATION UNRESTRICTED			

## 1.0 DISASSEMBLY APPLICATION

1.1 For the disassembling of the TPA and the CTW from the Housing Receptacle, we recommend the use of a slotted head screwdriver (Recommended dimensions 1.2x35mm).

1.1.1 Insert the screwdrivers between the TPA and the Housing and totally disengaged the TPA on each side.

1.1.2 Insert the screwdriver to unlock the Locking tab from the Housing.

1.1.2.1 Top Row

1.1.2.2 Bottom Row

1.1.3 Slightly pullout the CTW from the Housing.

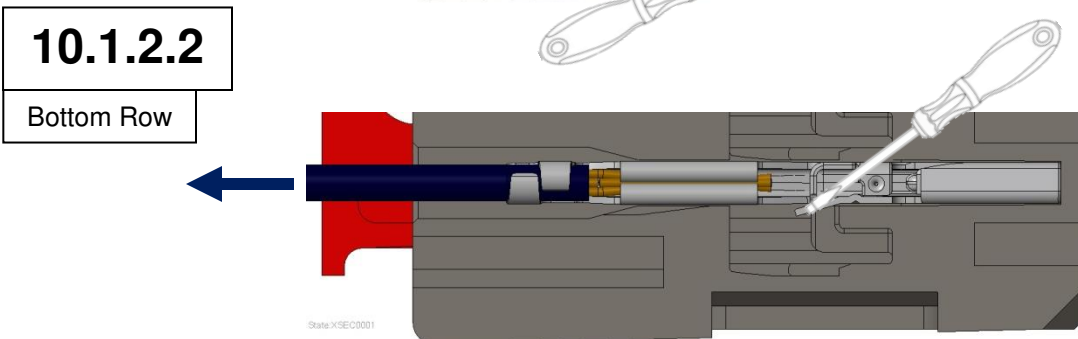
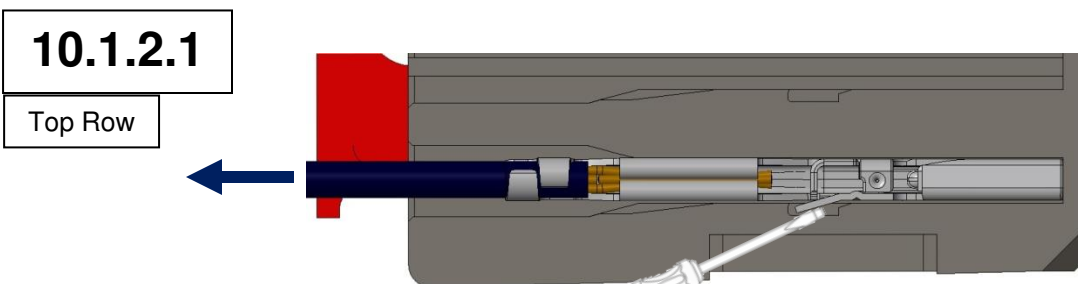
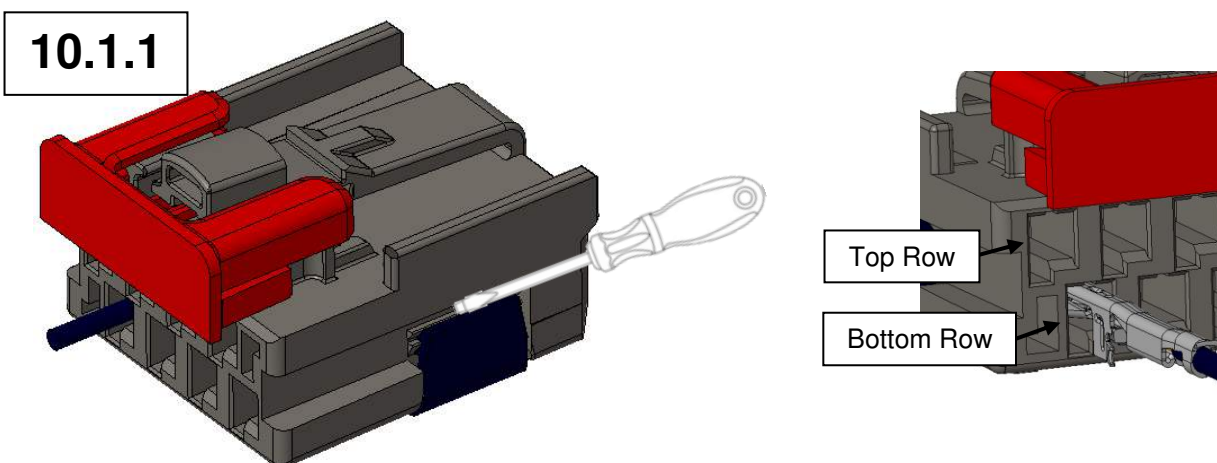

1.2 Once the CTW are dismantled from socket housing, the entire socket housing has to be replaced. The contact has to be visual check for contamination and damage (please see section 9.4).

NUMBER GS-20-0513	TYPE <b>Application Specification</b>		
TITLE <b>MINITEK MicroSpace™ connector</b>		PAGE 10 of 10	REVISION H
		AUTHORIZED BY VALLIERE Jérôme	DATE 05/06/2023
CLASSIFICATION <b>UNRESTRICTED</b>			

## 2.0 LAYOUT :

### 2.1 Solder Paste Thickness

Solder paste thickness for the connector contact on PCB pins side must be at least 0.15mm.  
For more details see norm IPC-7525 (Stencil Design Guidelines).

### 2.2 Stencil

The stencil aperture is determined by the circuit pad size and stencil thickness. It may be any shape as long as it prevents solder bridging from one pad to another. Generally, a thinner stencil will need a larger aperture to maintain the given volume of solder paste. The stencil should be 0.15 mm thick minimum. The stencil layout must be designed using the dimensions provided on the customer drawing for the specific connector. The coplanarity of the pc board circuits pads in the area of the layout must be 0.03 mm maxi.  
For more details see norm IPC-7525 (Stencil Design Guidelines).

## 3.0 Applied PCB's Comparative Tracking Index (CTI) :

According to IEC Standard 60664-1, in order to avoid any creepage and current leakage phenomenon, please use respectively PCB material by product :

### 3.1 For Minitek MicroSpace™ series :

Base material of PCB CTI  $\geq$  100, e.g. general FR-4 material's CTI is 175.

### 3.2 For Minitek MicroSpace™ High Voltage series :

Base material of PCB CTI  $\geq$  600 (Pollution degree 2)

NUMBER GS-20-0513	TYPE Application Specification		
TITLE <b>MINITEK MicroSpace™ connector</b>		PAGE 11 of 10	REVISION H
		AUTHORIZED BY VALLIERE Jérôme	DATE 05/06/2023
CLASSIFICATION <b>UNRESTRICTED</b>			

**REVISION RECORD**

<u>REV</u>	<u>PAGE</u>	<u>DESCRIPTION</u>	<u>EC#</u>	<u>DATE</u>
A	ALL	RELEASE	-	22/03/2019
B	ALL	MODIFY APPLICATION TOOLING TABLE (2)	F-35600	10/12/2019
C	ALL	ADD STRIP LENGTH IN TABLE (1)	F-35613	11/12/2019
D	2	ADD AWG24 INSULATION DIAMETER	F-36288	12/03/2020
E	7	PULL OUT FORCE CHANGE	F-36938	07/05/2020
F	ALL	MULTIPLE UPDATE	F-40745	22/04/2021
G	9	ADDED CHAPTER 11.0 LAYOUT	F-45104	20/06/2022
H	6,8,10	ADDED CTW SPEC + PCB CTI	F-48017	02/06/2023