

## RADIATION HARDENED PNP SILICON SWITCHING TRANSISTOR

Qualified per MIL-PRF-19500/291

### DEVICES

<b>2N2906A</b>	<b>2N2907A</b>
<b>2N2906AL</b>	<b>2N2907AL</b>
<b>2N2906AUA</b>	<b>2N2907AUA</b>
<b>2N2906AUB</b>	<b>2N2907AUB</b>
<b>2N2906AUBC</b>	<b>2N2907AUBC</b>

### LEVELS

<b>JANSM – 3K Rads (Si)</b>
<b>JANSD – 10K Rads (Si)</b>
<b>JANSP – 30K Rads (Si)</b>
<b>JANSL – 50K Rads (Si)</b>
<b>JANSR – 100K Rads (Si)</b>

### ABSOLUTE MAXIMUM RATINGS ( $T_C = +25^\circ\text{C}$ unless otherwise noted)

Parameters / Test Conditions	Symbol	Value	Unit
Collector-Emitter Voltage	$V_{CEO}$	60	Vdc
Collector-Base Voltage	$V_{CBO}$	60	Vdc
Emitter-Base Voltage	$V_{EBO}$	5.0	Vdc
Collector Current	$I_C$	600	mAdc
Total Power Dissipation @ $T_A = +25^\circ\text{C}$	$P_T^{(1)}$	0.5	W
Operating & Storage Junction Temperature Range	$T_{op}, T_{stg}$	-65 to +200	$^\circ\text{C}$

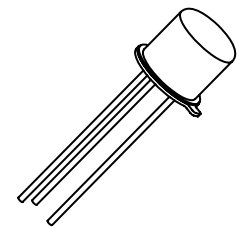

**TO-18 (TO-206AA)**  
 2N2906A, 2N2907A

### THERMAL CHARACTERISTICS

Parameters / Test Conditions	Symbol	Max.	Unit
Thermal Resistance, Junction-to-Ambient	$R_{\theta JA}^{(1)}$	325	$^\circ\text{C/W}$

1. See MIL-PRF-19500/291 for derating curves.

### ELECTRICAL CHARACTERISTICS ( $T_A = +25^\circ\text{C}$ , unless otherwise noted)

Parameters / Test Conditions	Symbol	Min.	Max.	Unit
<b>OFF CHARACTERISTICS</b>				
Collector-Emitter Breakdown Voltage $I_C = 10\text{mAdc}$	$V_{(BR)CEO}$	60		Vdc
Collector-Base Cutoff Current $V_{CB} = 60\text{Vdc}$ $V_{CB} = 50\text{Vdc}$	$I_{CBO}$		10 10	$\mu\text{Adc}$ $\eta\text{Adc}$
Emitter-Base Cutoff Current $V_{EB} = 5.0\text{Vdc}$ $V_{EB} = 4.0\text{Vdc}$	$I_{EBO}$		10 50	$\mu\text{Adc}$ $\eta\text{Adc}$
Collector-Emitter Cutoff Current $V_{CE} = 50\text{Vdc}$	$I_{CES}$		50	$\eta\text{Adc}$

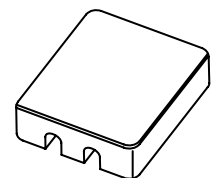

**4 PIN**  
 2N2906AUA, 2N2907AUA

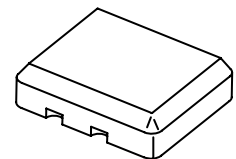

**3 PIN**  
 2N2906AUB, 2N2907AUB  
 2N2906AUBC, 2N2907AUBC  
 (UBC = Ceramic Lid Version)

## ELECTRICAL CHARACTERISTICS ( $T_A = +25^\circ\text{C}$ , unless otherwise noted)

Parameters / Test Conditions	Symbol	Min.	Max.	Unit
<b>ON CHARACTERISTICS <sup>(2)</sup></b>				
Forward-Current Transfer Ratio $I_C = 0.1\text{mA}$ , $V_{CE} = 10\text{Vdc}$ 2N2906A, L, UA, UB, UBC 2N2907A, L, UA, UB, UBC	$h_{FE}$	40		
		75		
$I_C = 1.0\text{mA}$ , $V_{CE} = 10\text{Vdc}$ 2N2906A, L, UA, UB, UBC 2N2907A, L, UA, UB, UBC		40	175	
		100	450	
$I_C = 10\text{mA}$ , $V_{CE} = 10\text{Vdc}$ 2N2906A, L, UA, UB, UBC 2N2907A, L, UA, UB, UBC		40		
		100		
$I_C = 150\text{mA}$ , $V_{CE} = 10\text{Vdc}$ 2N2906A, L, UA, UB, UBC 2N2907A, L, UA, UB, UBC		40	120	
		100	300	
$I_C = 500\text{mA}$ , $V_{CE} = 10\text{Vdc}$ 2N2906A, L, UA, UB, UBC 2N2907A, L, UA, UB, UBC		40		
		50		
Collector-Emitter Saturation Voltage $I_C = 150\text{mA}$ , $I_B = 15\text{mA}$ $I_C = 500\text{mA}$ , $I_B = 50\text{mA}$	$V_{CE(sat)}$		0.4 1.6	Vdc
Base-Emitter Voltage $I_C = 150\text{mA}$ , $I_B = 15\text{mA}$ $I_C = 500\text{mA}$ , $I_B = 50\text{mA}$	$V_{BE(sat)}$	0.6	1.3 2.6	Vdc

## DYNAMIC CHARACTERISTICS

Parameters / Test Conditions	Symbol	Min.	Max.	Unit
Small-Signal Short-Circuit Forward Current Transfer Ratio $I_C = 1.0\text{mA}$ , $V_{CE} = 10\text{Vdc}$ , $f = 1.0\text{kHz}$ 2N2906A, L, UA, UB, UBC 2N2907A, L, UA, UB, UBC	$h_{fe}$	40 100		
Magnitude of Small-Signal Short-Circuit Forward Current Transfer Ratio $I_C = 20\text{mA}$ , $V_{CE} = 20\text{Vdc}$ , $f = 100\text{MHz}$	$ h_{fe} $	2.0		
Output Capacitance $V_{CB} = 10\text{Vdc}$ , $I_E = 0$ , $100\text{kHz} \leq f \leq 1.0\text{MHz}$	$C_{obo}$		8.0	pF
Input Capacitance $V_{EB} = 2.0\text{Vdc}$ , $I_C = 0$ , $100\text{kHz} \leq f \leq 1.0\text{MHz}$	$C_{ibo}$		30	pF

## SWITCHING CHARACTERISTICS

Parameters / Test Conditions	Symbol	Min.	Max.	Unit
Turn-On Time See MIL-PRF-19500/291	$t_{on}$		45	ns
Turn-Off Time See MIL-PRF-19500/291	$t_{off}$		300	ns

(2) Pulse Test: Pulse Width = 300 $\mu\text{s}$ , Duty Cycle  $\leq 2.0\%$ .

**PACKAGE DIMENSIONS**

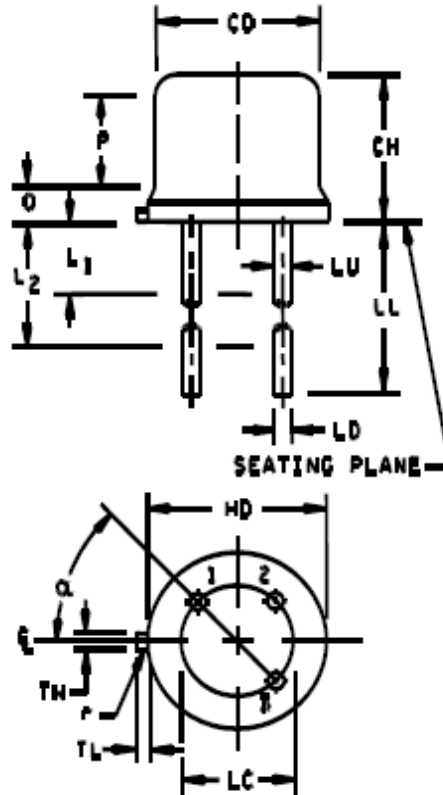

**NOTES:**

1. Dimensions are in inches.
2. Millimeters are given for general information only.
3. Beyond r (radius) maximum, TW shall be held for a minimum length of .011 inch (0.28 mm).
4. Dimension TL measured from maximum HD.
5. Body contour optional within zone defined by HD, CD, and Q.
6. Leads at gauge plane .054 +.001 -.000 inch (1.37 +0.03 -0.00 mm) below seating plane shall be within .007 inch (0.18 mm) radius of true position (TP) at maximum material condition (MMC) relative to tab at MMC.
7. Dimension LU applies between L<sub>1</sub> and L<sub>2</sub>. Dimension LD applies between L<sub>2</sub> and LL minimum. Diameter is uncontrolled in L<sub>1</sub> and beyond LL minimum.
8. All three leads.
9. The collector shall be internally connected to the case.
10. Dimension r (radius) applies to both inside corners of tab.
11. In accordance with ASME Y14.5M, diameters are equivalent to  $\phi$ x symbology.
12. Lead 1 = emitter, lead 2 = base, lead 3 = collector.
13. For L suffix devices, dimension LL = 1.5 inches (38.10 mm) min. and 1.75 inches (44.45 mm) max.

Symbol	Dimensions				Note
	Inches		Millimeters		
	Min	Max	Min	Max	
CD	.178	.195	4.52	4.95	
CH	.170	.210	4.32	5.33	
HD	.209	.230	5.31	5.84	
LC	.100 TP		2.54 TP		6
LD	.016	.021	0.41	0.53	7,8
LL	.500	.750	12.70	19.05	7,8,13
LU	.016	.019	0.41	0.48	7,8
L <sub>1</sub>		.050		1.27	7,8
L <sub>2</sub>	.250		6.35		7,8
P	.100		2.54		
Q		.030		0.76	5
TL	.028	.048	0.71	1.22	3,4
TW	.036	.046	0.91	1.17	3
r		.010		0.25	10
$\alpha$	45° TP		45° TP		6

**FIGURE 1. Physical dimensions (similar to TO-18)**

6 Lake Street, Lawrence, MA 01841  
 1-800-446-1158 / (978) 620-2600 / Fax: (978) 689-0803  
 Website: <http://www.microsemi.com>

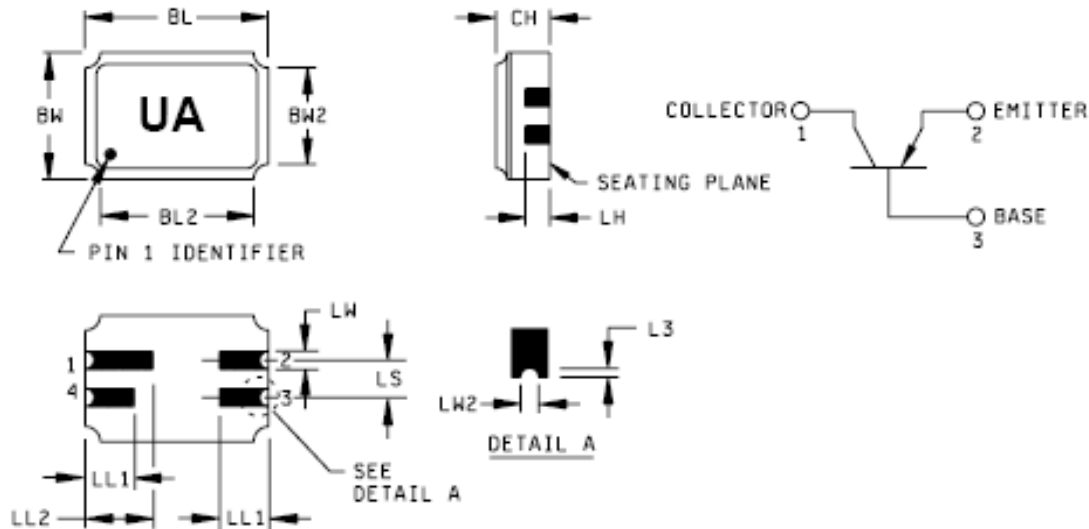

### NOTES:

1. Dimensions are in inches.
2. Millimeters are given for general information only.
3. Dimension CH controls the overall package thickness. When a window lid is used, dimension CH must increase by a minimum of .010 inch (0.254 mm) and a maximum of .040 inch (1.020 mm).
4. The corner shape (square, notch, radius) may vary at the manufacturer's option, from that shown on the drawing.
5. Dimensions LW2 minimum and L3 minimum and the appropriate castellation length define an unobstructed three-dimensional space traversing all of the ceramic layers in which a castellation was designed. (Castellations are required on the bottom two layers, optional on the top ceramic layer.) Dimension "LW2" maximum and "L3" maximum define the maximum width and depth of the castellation at any point on its surface. Measurement of these dimensions may be made prior to solder dipping.
6. The co-planarity deviation of all terminal contact points, as defined by the device seating plane, shall not exceed .006 inch (0.15mm) for solder dipped leadless chip carriers.
7. In accordance with ASME Y14.5M, diameters are equivalent to  $\phi x$  symbology.

Symbol	Dimensions				Note
	Inches		Millimeters		
	Min	Max	Min	Max	
BL	.215	.225	5.46	5.71	
BL2		.225		5.71	
BW	.145	.155	3.68	3.93	
BW2		.155		3.93	
CH	.061	.075	1.55	1.90	3
L3	.003	.007	0.08	0.18	5
LH	.029	.042	0.74	1.07	
LL1	.032	.048	0.81	1.22	
LL2	.072	.088	1.83	2.23	
LS	.045	.055	1.14	1.39	
LW	.022	.028	0.56	0.71	
LW2	.006	.022	0.15	0.56	5

Pin no.	1	2	3	4
Transistor	Collector	Emitter	Base	N/C

**FIGURE 2. Physical dimensions, surface mount (UA version)**

6 Lake Street, Lawrence, MA 01841  
 1-800-446-1158 / (978) 620-2600 / Fax: (978) 689-0803  
 Website: <http://www.microsemi.com>

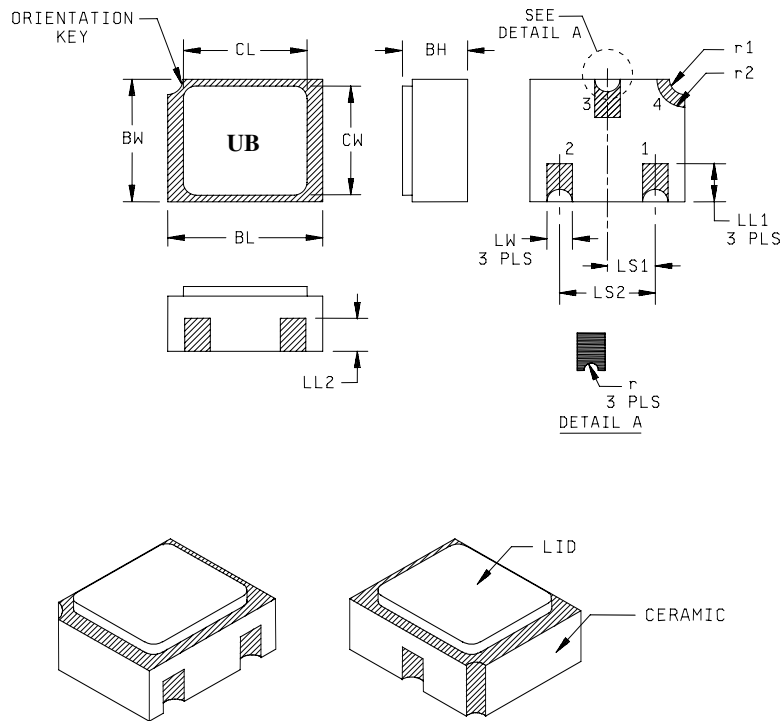

Symbol	Dimensions				Note
	Inches		Millimeters		
	Min	Max	Min	Max	
BH	.046	.056	1.17	1.42	
BL	.115	.128	2.92	3.25	
BW	.085	.108	2.16	2.74	
CL		.128		3.25	
CW		.108		2.74	
LL1	.022	.038	0.56	0.96	
LL2	.017	.035	0.43	0.89	

Symbol	Dimensions				Note
	Inches		Millimeters		
	Min	Max	Min	Max	
LS <sub>1</sub>	.036	.040	0.91	1.02	
LS <sub>2</sub>	.071	.079	1.81	2.01	
LW	.016	.024	0.41	0.61	
r		.008		.203	
r <sub>1</sub>		.012		.305	
r <sub>2</sub>		.022		.559	

**NOTES:**

1. Dimensions are in inches.
2. Millimeters are given for general information only.
3. Pad 1 = Base, Pad 2 = Emitter, Pad 3 = Collector, Pad 4 = Shielding connected to the lid.
4. In accordance with ASME Y14.5M, diameters are equivalent to  $\phi x$  symbology.

**FIGURE 3. Physical dimensions, surface mount (UB version)**

6 Lake Street, Lawrence, MA 01841  
 1-800-446-1158 / (978) 620-2600 / Fax: (978) 689-0803  
 Website: <http://www.microsemi.com>

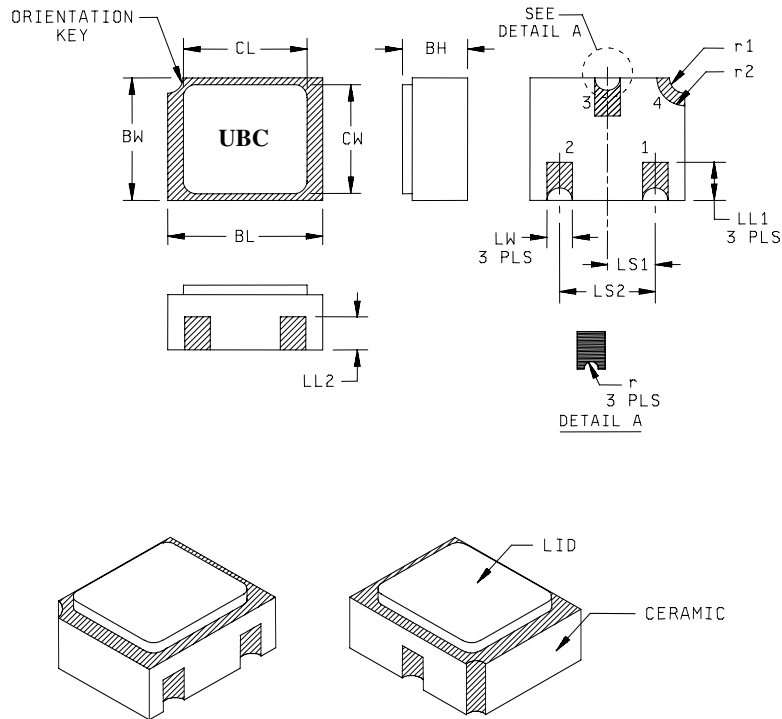

Symbol	Dimensions				Note
	Inches		Millimeters		
	Min	Max	Min	Max	
BH	.046	.071	1.17	1.80	
BL	.115	.128	2.92	3.25	
BW	.085	.108	2.16	2.74	
CL		.128		3.25	
CW		.108		2.74	
LL1	.022	.038	0.56	0.96	
LL2	.017	.035	0.43	0.89	

Symbol	Dimensions				Note
	Inches		Millimeters		
	Min	Max	Min	Max	
LS <sub>1</sub>	.036	.040	0.91	1.02	
LS <sub>2</sub>	.071	.079	1.81	2.01	
LW	.016	.024	0.41	0.61	
r		.008		.203	
r <sub>1</sub>		.012		.305	
r <sub>2</sub>		.022		.559	

**NOTES:**

1. Dimensions are in inches.
2. Millimeters are given for general information only.
3. Hatched areas on package denote metalized areas.
4. Pad 1 = Base, Pad 2 = Emitter, Pad 3 = Collector, Pad 4 = Connected to the lid braze ring.
5. In accordance with ASME Y14.5M, diameters are equivalent to  $\phi$ x symbology.

**FIGURE 4. Physical dimensions, surface mount (UBC version, ceramic lid)**