

**UNIVERSAL SCREW RECEPTACLE**  
**FOR AXIS 0.3 MM**

**R127.601.001**

Series : SMA2.9

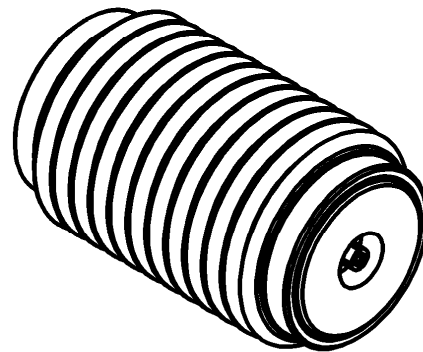
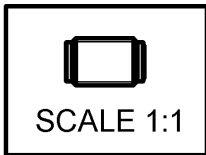
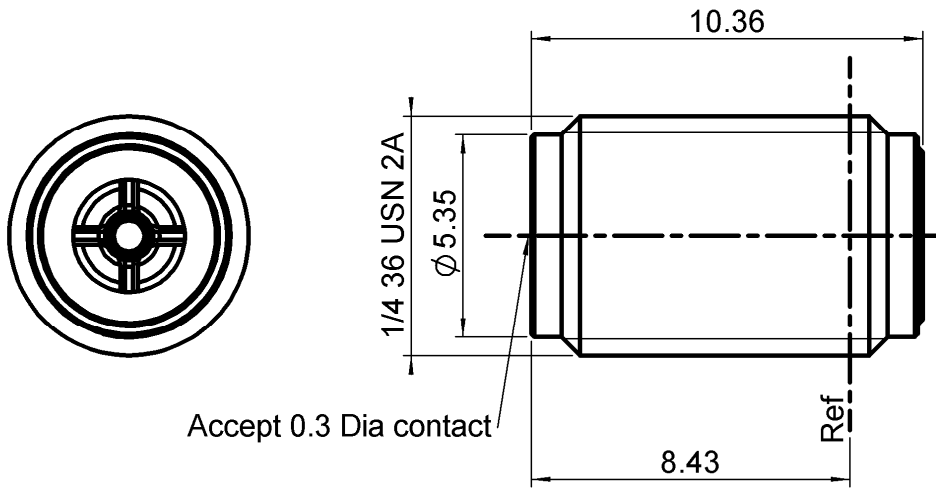

All dimensions are in mm.

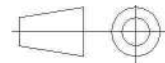

COMPONENTS	MATERIALS	PLATINGS (µm)
BODY	STAINLESS STEEL	PASSIVATED
CENTER CONTACT	BERYLLIUM COPPER	GOLD 1.3 OVER NICKEL 2
OUTER CONTACT	-	-
INSULATOR	POLYIMIDE KAPTON 500H	-
GASKET	-	-
OTHERS PARTS	BRASS	GOLD 0.2 OVER NICKEL 2
-	-	-
-	-	-

Issue : 1018 C

In the effort to improve our products, we reserve the right to make changes judged to be necessary.



**UNIVERSAL SCREW RECEPTACLE**

**R127.601.001**

**FOR AXIS 0.3 MM**

Series : SMA2.9

**PACKAGING**

**SPECIFICATION**

Standard	Unit	Other
<b>1</b>	-	<b>Contact us</b>

**ELECTRICAL CHARACTERISTICS**

**ENVIRONMENTAL**

Impedance	<b>50</b>	$\Omega$
Frequency	<b>0-46</b>	GHz
VSWR	<b>1.05 + 0,0060</b>	x F(GHz) Maxi
Insertion loss	-	$\sqrt{F(GHz)}$ dB Maxi
RF leakage	- (	- F(GHz)) dB Maxi
Voltage rating	<b>250</b>	Veff Maxi
Dielectric withstanding voltage	<b>750</b>	Veff mini
Insulation resistance	<b>5000</b>	M $\Omega$ mini

Operating temperature	<b>-65,+165</b>	$^{\circ}$ C
Hermetic seal	<b>NA</b>	Atm.cm3/s
Panel leakage	<b>NA</b>	

**OTHERS CHARACTERISTICS**

Assembly instruction

Others :

**MECHANICAL CHARACTERISTICS**

Center contact retention		
Axial force – Mating end	<b>15</b>	N mini
Axial force – Opposite end	<b>15</b>	N mini
Torque	<b>NA</b>	N.cm mini
Recommended torque		
Mating	<b>NA</b>	N.cm
Panel nut	<b>190</b>	N.cm
Mating life	<b>500</b>	Cycles mini
Weight	<b>1,8040</b>	g

Issue : 1018 C

In the effort to improve our products, we reserve the right to make changes judged to be necessary.



**UNIVERSAL SCREW RECEPTACLE**

**R127.601.001**

**FOR AXIS 0.3 MM**

Series : SMA2.9

**Panel drilling for sercewing receptacle SMA 2.9**

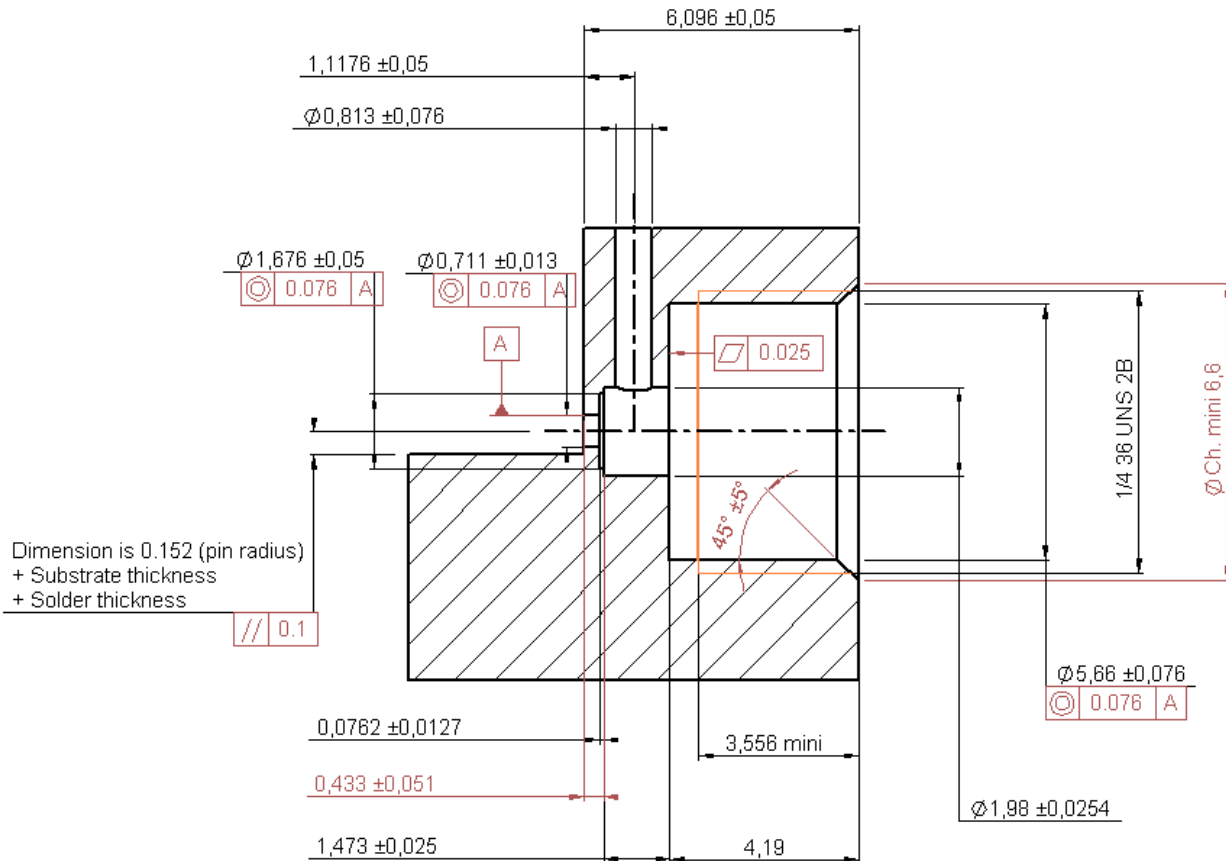

To obtain correct concentricity and dimensions on the receptacle piercing,  
 we recommend to use RADIALL special tools:  
**R282.080.000** piercing tool  
**and R282.082.000** screwing tool

Issue : 1018 C

In the effort to improve our products, we reserve the right to make changes judged to be necessary.



**UNIVERSAL SCREW RECEPTACLE**

**R127.601.001**

**FOR AXIS 0.3 MM**

Series : SMA2.9

1

**SOLDERING of the glass bead**

Set up of the R280.760.000 glass bead in the housing.  
keep the glass bead into position thanks to  
R282.745.000 positionner

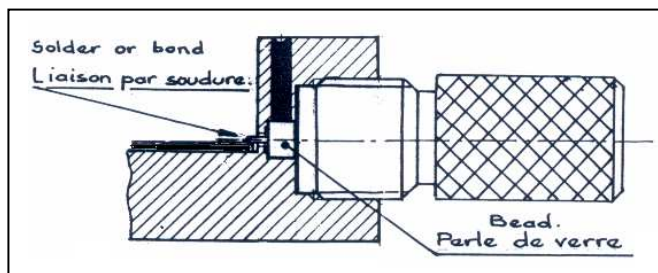

3

**MOUNTING of the flange on the box**

Set up the R282.860.000 position gauge on the flange  
to ensure a good concentricity.  
Screw the assembly on the housing.

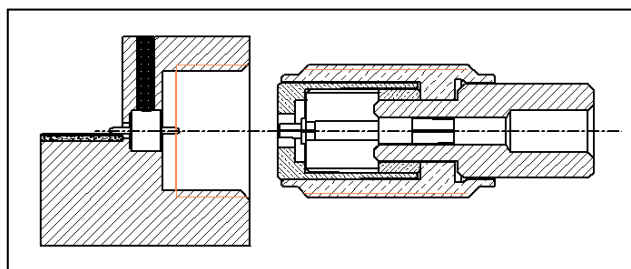

2

**POSITION of the glass bead after soldering**

Check the soldering quality as well as the position of

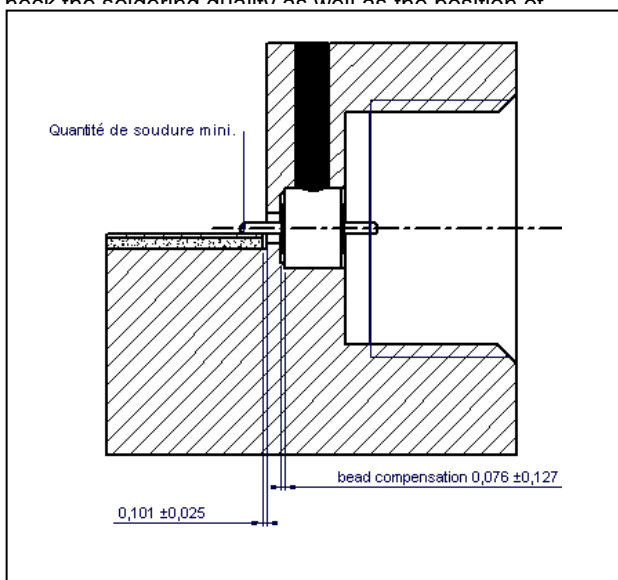

4

**Locking of the flange on the box**

Lock the flange on the housing thanks to  
R282.341.010 dynamometer screw-driver

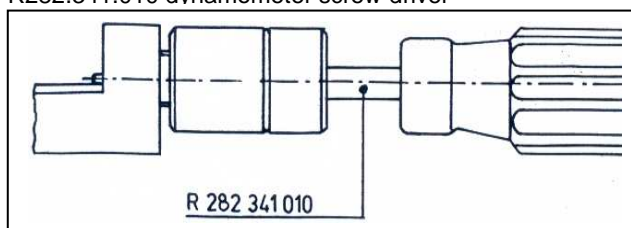

Issue : 1018 C

In the effort to improve our products, we reserve the right to make changes judged to be necessary.



**UNIVERSAL SCREW RECEPTACLE  
FOR AXIS 0.3 MM**

**R127.601.001**

Series : SMA2.9

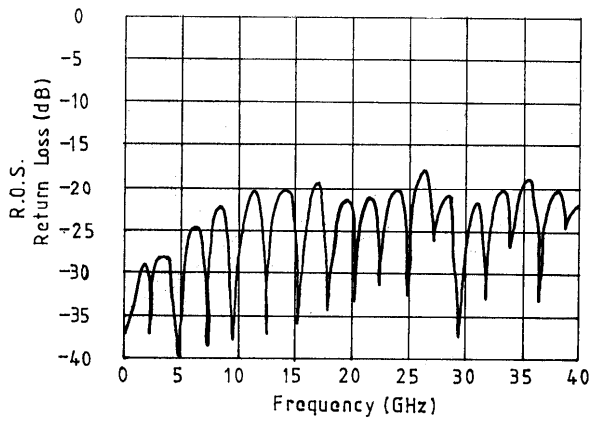

Typical return loss of a connector pair with two glass beads joined by 1 inch microstrip

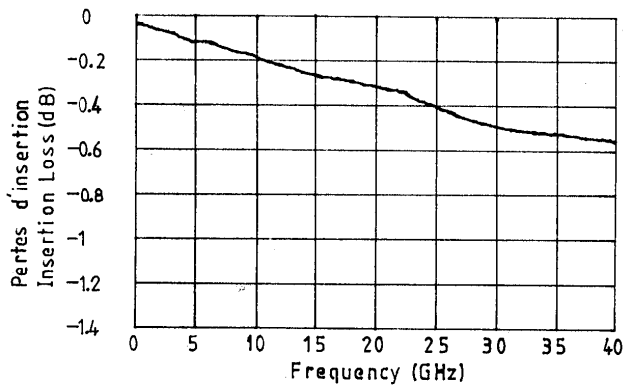
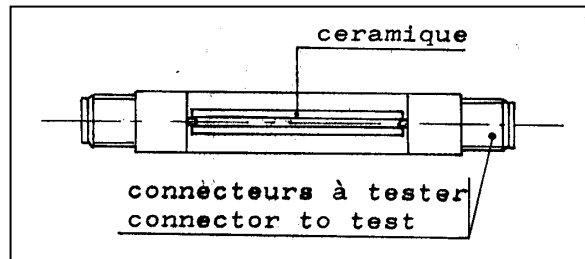

Insertion loss measurements in coaxial circuit with glass bead

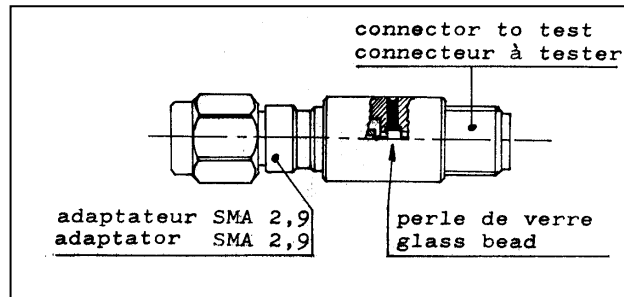

Issue : 1018 C

In the effort to improve our products, we reserve the right to make changes judged to be necessary.

