

THIS DRAWING IS UNPUBLISHED. RELEASED FOR PUBLICATION
 © COPYRIGHT - By - ALL RIGHTS RESERVED.

REVISIONS				
P	LTR	DESCRIPTION	DATE	APVD
V2		REVISED PER ECO-16-004800	12SEP2016	NK MZ

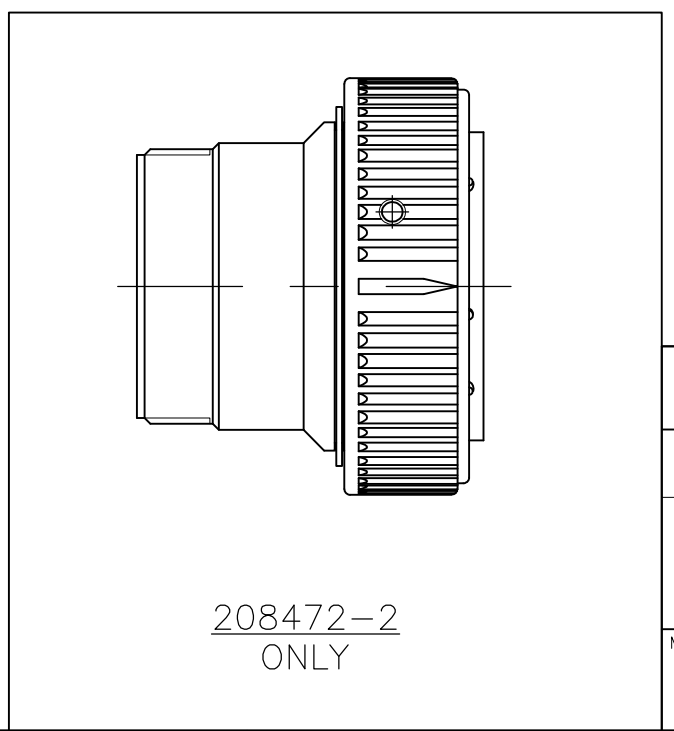
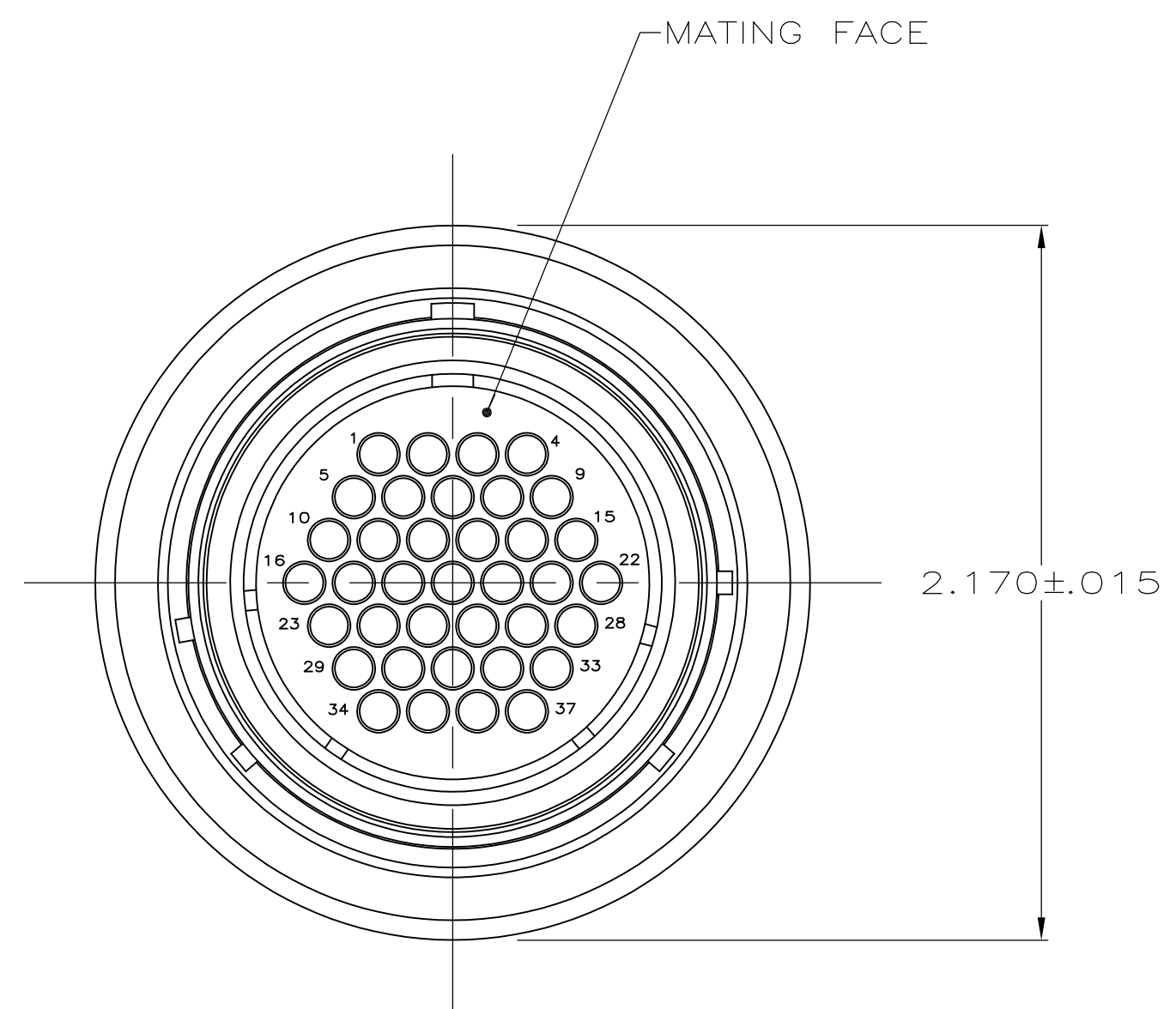
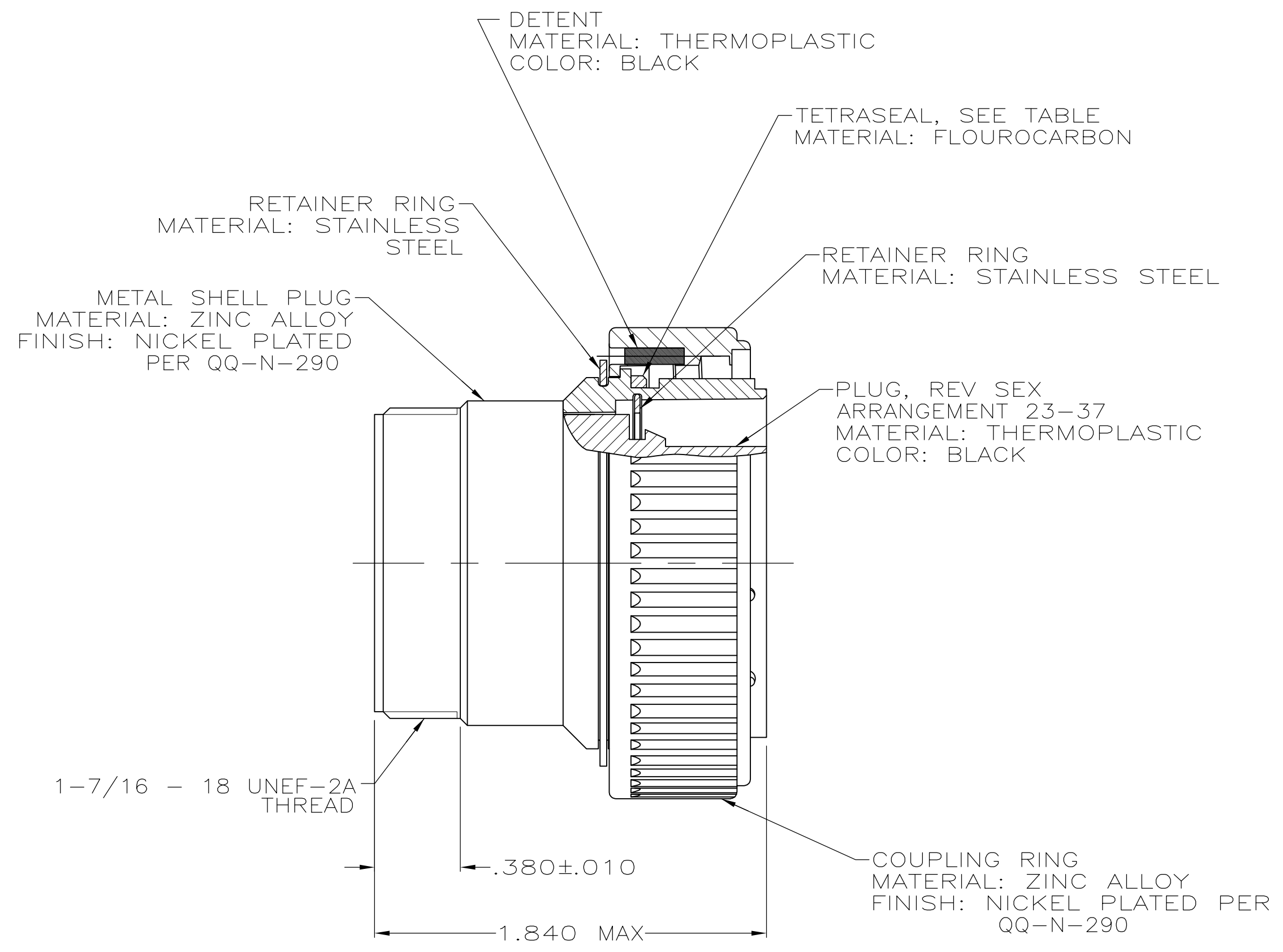

OBSOLETE	NO	YES	-208472-3-
	YES	YES	-208472-2-
	NO	NO	208472-1
SECONDARY LOCKING FEATURE	TETRASEAL	PART NUMBER	

1 AMP PART NUMBER AND DATE CODE TO BE LOCATED ON COUPLING RING.

THIS DRAWING IS A CONTROLLED DOCUMENT.

DIMENSIONS: INCHES	TOLERANCES UNLESS OTHERWISE SPECIFIED:	DWN R.LEE BG 6-25-91	
	0 PLC ± - 1 PLC ± - 2 PLC ± - 3 PLC ± - 4 PLC ± - ANGLES ± -	CHK W.G.LENKER 4-16-92 APVD - PRODUCT SPEC 108-10040 APPLICATION SPEC -	
MATERIAL SEE CALLOUT	FINISH SEE CALLOUT	WEIGHT -	SIZE A2 CAGE CODE 00779 DRAWING NO C-208472 RESTRICTED TO - CUSTOMER DRAWING SCALE 2:1 SHEET 1 of 1 REV V2