



soberton inc.

# SP DYNAMIC SPEAKER UNIT

Acoustic Product Specification

Product Number: SP-5709



Release | Revision: C/2018

## CONTENTS

This document contains the technical specifications for the dynamic speaker unit.

**Page 1**  
Speaker Electroacoustic Characteristics

General Specifications

**Page 2**  
Reliability Tests

**Page 3**  
Measuring Method (Speaker Mode)

Standard Test Condition of Speakers

**Page 4**  
Frequency Response Curve

**Page 5**  
Dimensions

**Page 6**  
Packing

## Dynamic Speaker Electroacoustic Characteristics

### Sound Pressure Level

96±3dB SPL @0.6, 0.8,1.0 and1.2KHz in average (0dB SPL=20μPa)  
Measuring Condition: 0.1W (Sine wave) 10cm measured with baffler shown in Fig.1.

### Frequency Range

F0 Hz~6K Hz shown in Fig.2

### Response Frequency

400±20%Hz @ 1V. (Without Baffler)

### Input Power (Nominal and Maximum)

Rated Noise Power 0.5W

Short Term Max Power: 1.0W must be normal at a white noise for one minute

### Buzzer and Rattles

Must be normal sine signal at 2.83V from F0Hz ~ 6KHz sweeping

### Distortion

Less than 5% @1KHz, 0.1W

## General Specifications

### Operating Temperature Range

-20°C~+65°C

### Storage Temperature Range

-30°C~+70°C

### Standard Test Conditions

Temperature 17°C~25°C

Relative Humidity 45%~80%(RH)

### AC Impedance

8±15%Ω (@2KHz 1V) without baffler

### Dimension

Ø57.0x8.5mm

### IP Level

No rating



soberton inc.

## SP DYNAMIC SPEAKER UNIT

Acoustic Product Specification

Product Number: SP-5709



Release | Revision: C/2018

### CONTENTS

This document contains the technical specifications for the dynamic speaker unit.

#### Page 1

Speaker Electroacoustic Characteristics

General Specifications

#### Page 2

Reliability Tests

#### Page 3

Measuring Method (Speaker Mode)

Standard Test Condition of Speakers

#### Page 4

Frequency Response Curve

#### Page 5

Dimensions

#### Page 6

Packing

## Reliability Tests

### After Test

Sound pressure level of speaker difference shall be within  $\pm 3\text{dB}$  after test @0.8, 1.0, 1.2, 1.5KHz average.

### High Temperature Test

High Temperature  $+65\pm 3^\circ\text{C}$

Duration 96 hours

### Low Temperature Test

Low Temperature  $-20\pm 3^\circ\text{C}$

Duration 96 hours

### Humidity Test

Temperature  $+40\pm 2^\circ\text{C}$

Relative Humidity 90%~95%

Duration 96 hours

### Temperature Cycle Test

Temperature  $-20^\circ\text{C}$   $+65^\circ\text{C}$

Duration 2 hours 2 hours

Cycle 5

### Drop Test

Height 1.5 m

Cycle 12 cycles

### Drop Test

Vibration 10Hz ~ 55Hz ~ 10Hz Oct/min

Amplitude 1.5mm

Duration 2 hours in each of 3 axes

### Load Test

Speaker mode: White noise (EIA filter) for 96 hours @ 0.5W input power.



soberton inc.

# SP DYNAMIC SPEAKER UNIT

Acoustic Product Specification

Product Number: SP-5709



Release | Revision: C/2018

## CONTENTS

This document contains the technical specifications for the dynamic speaker unit.

**Page 1**  
Speaker Electroacoustic Characteristics

General Specifications

**Page 2**  
Reliability Tests

**Page 3**  
Measuring Method (Speaker Mode)

Standard Test Condition of Speakers

**Page 4**  
Frequency Response Curve

**Page 5**  
Dimensions

**Page 6**  
Packing

## Measuring Method (Speaker Mode)

### Standard Test Condition

Temperature 17 ~ 25°C

Relative humidity 45% ~ 85%

Atmospheric pressure 860hpa to 1060hpa

### Standard Test Fixture

Input Power 0.1W

Zero Level -dB

Mode TSR

Potentiometer Range 50dB

Sweep Time 0.5sec

## Standard Test Condition of Speaker (Fig. 1)

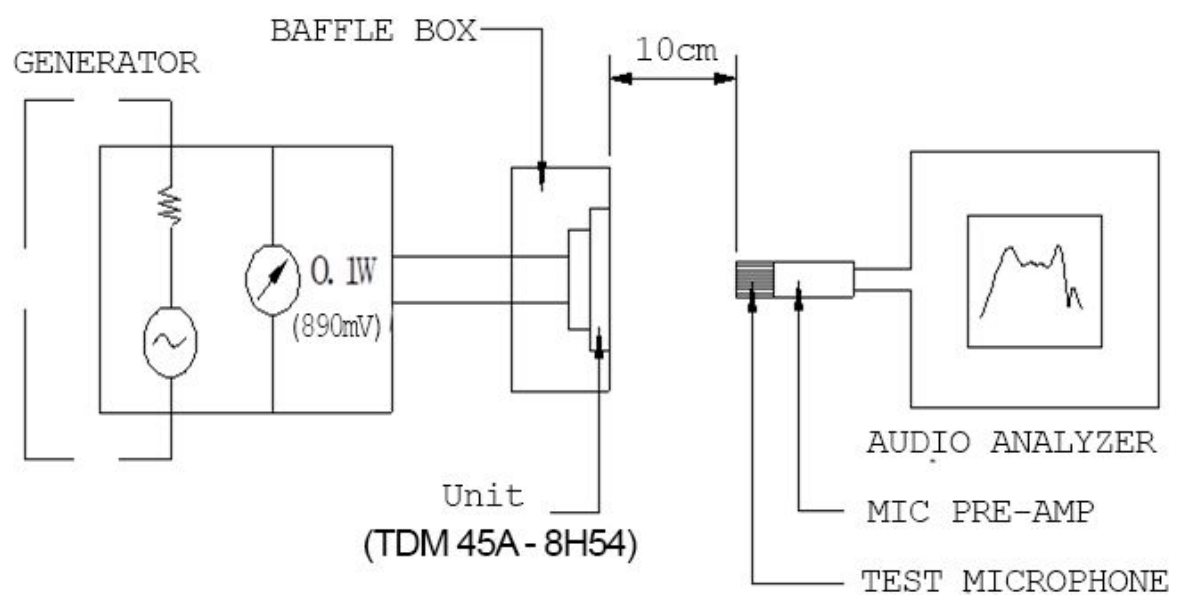



soberton inc.

## SP DYNAMIC SPEAKER UNIT

Acoustic Product Specification

Product Number: SP-5709



Release | Revision: C/2018

### CONTENTS

This document contains the technical specifications for the dynamic speaker unit.

#### Page 1

Speaker Electroacoustic Characteristics

General Specifications

#### Page 2

Reliability Tests

#### Page 3

Measuring Method (Speaker Mode)

Standard Test Condition of Speakers

#### Page 4

Frequency Response Curve

#### Page 5

Dimensions

#### Page 6

Packing

Frequency Response Curve (Fig. 2)

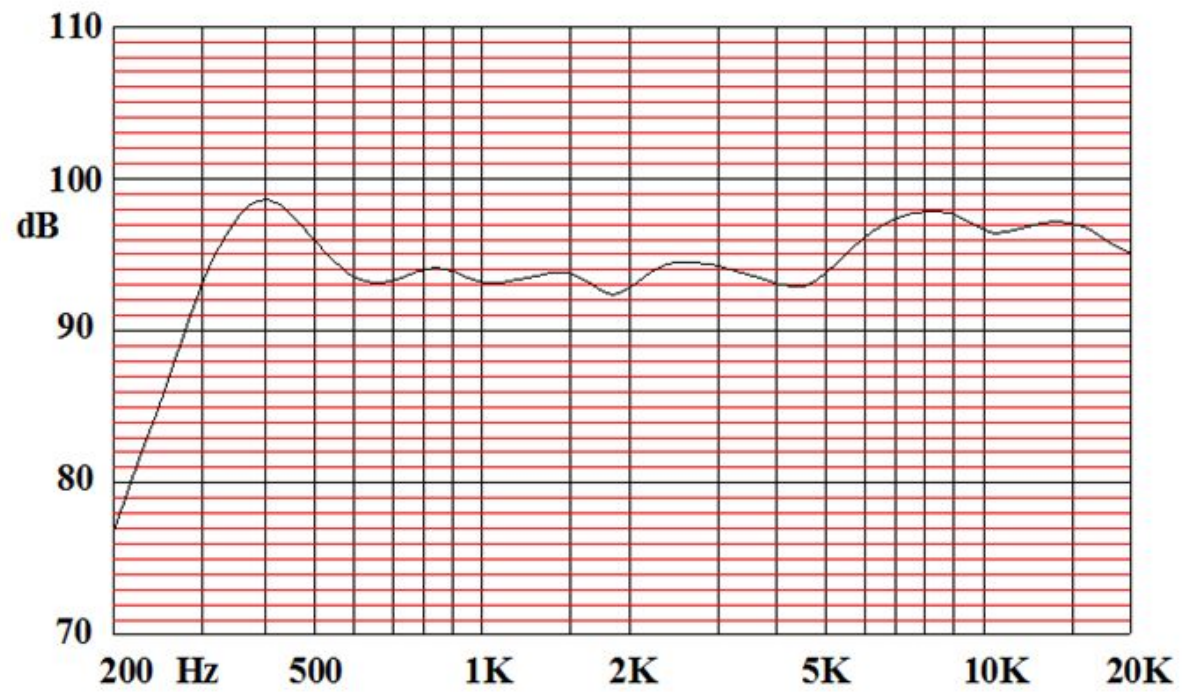



soberton inc.

# SP DYNAMIC SPEAKER UNIT

Acoustic Product Specification

Product Number: SP-5709



Release | Revision: C/2018

## CONTENTS

This document contains the technical specifications for the dynamic speaker unit.

**Page 1**  
Speaker Electroacoustic Characteristics

General Specifications

**Page 2**  
Reliability Tests

**Page 3**  
Measuring Method (Speaker Mode)

Standard Test Condition of Speakers

**Page 4**  
Frequency Response Curve

**Page 5**  
Dimensions

**Page 6**  
Packing

## Dimensions

Tolerance:  $\pm 0.2$  (unit: mm)

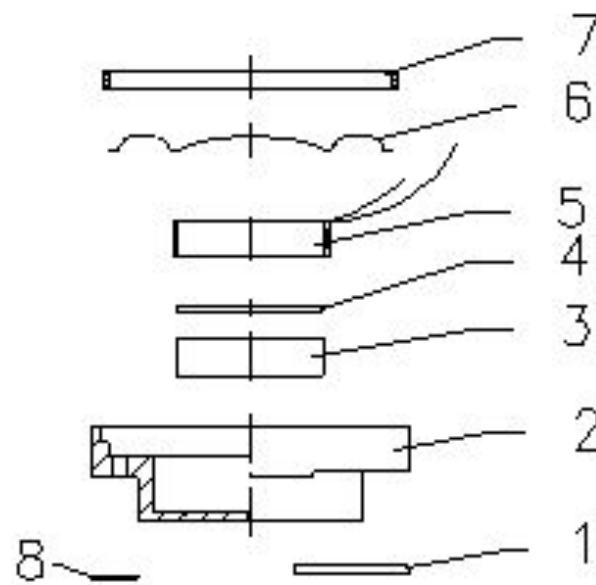
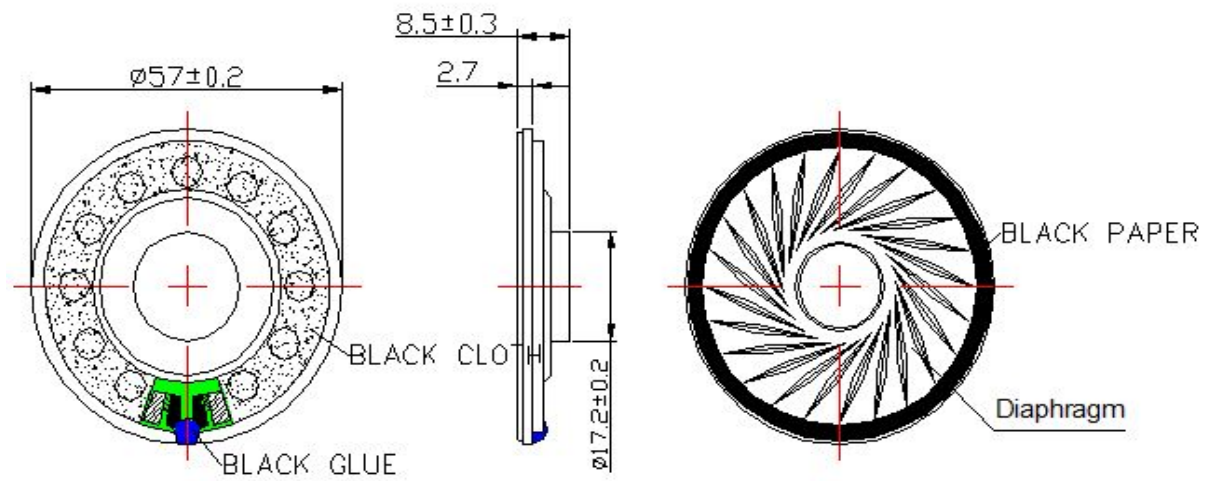

No.	Part Name	Material	Quantity
1	Diaphragm	PET	1
2	Magnet	Nd Fe B	1
3	Plate	SPCC	1
4	Voice Coil	Polyurethane Enamelled Wire	1
5	Frame	SPCC	1
6	PCB	FR-4	1
7	Gasket	Paper	1
8	Silk Screen	Adhesive	1



soberton inc.

# SP DYNAMIC SPEAKER UNIT

Acoustic Product Specification

Product Number: SP-5709



Release | Revision: C/2018

## CONTENTS

This document contains the technical specifications for the dynamic speaker unit.

### Page 1

Speaker Electroacoustic Characteristics

General Specifications

### Page 2

Reliability Tests

### Page 3

Measuring Method (Speaker Mode)

Standard Test Condition of Speakers

### Page 4

Frequency Response Curve

### Page 5

Dimensions

### Page 6

Packing

## Packing

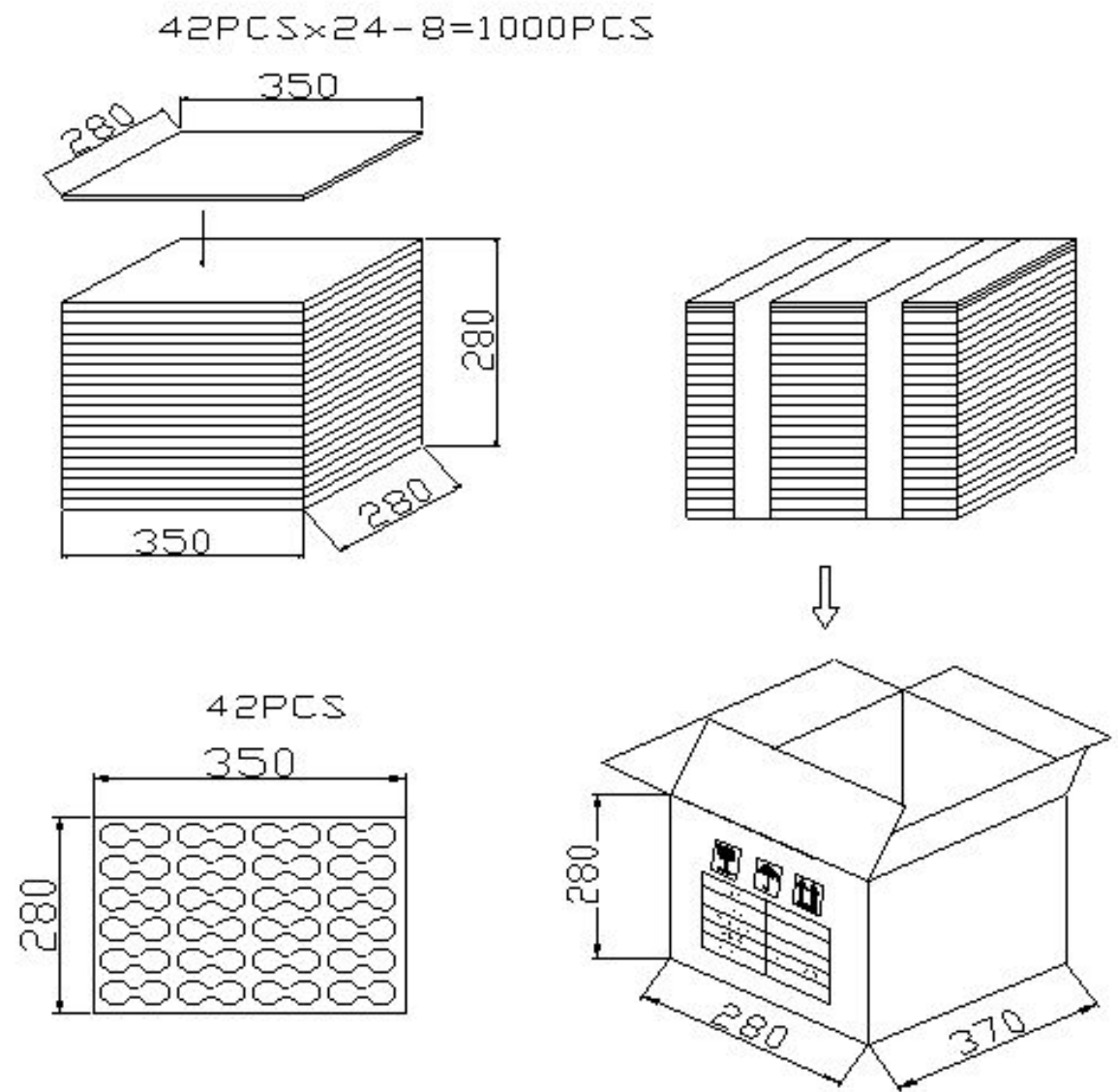

## Details

42 pcs per box

24 units per box

### Total

Amount  
1000 pcs per  
box(42x24-8=1000)

Size  
37x28x28cm