



## XC120 Connector Board Product Brief

XC120 Connector Board Product Brief

Proprietary and Confidential

Author: Acconeer

Version 1.0: 2022-07-06

## Table of Contents

1. Introduction .....	4
2. XC120 Evaluation Board. ....	5
2.1 Overview .....	5
2.2 Power.....	5
3. Revision History.....	9
4. Disclaimer .....	10

# 1. Introduction

The A121 EVK is an evaluation kit designed to evaluate the Acconeer A121 pulsed coherent radar sensor. The kit consists of three boards: the XC120, XE121 and XS121. The XC120 board carries a cortex M7 MCU which is to be flashed with a software dedicated to stream data from the A121 radar sensor to Acconeer’s “Exploration Tool” via USB HS 2.0<sup>1</sup>. The XC120 is intended to be used with the exploration server for streaming radar sensor data only and after flashing, no further configuration by the user is expected. The XE121 features an on board A121 pulsed coherent radar sensor and the possibility to add up to four additional A121 radar sensors via FFC (Flat Flexible Cable) to the XS121 satellite boards. This document focuses on the XC120 board. For details on XE121 and XS121 refer to the respective product briefs. For details on how to use the XC120, XE121 and XS121, refer to the A121 EVK Hardware User Guide available on the Acconeer Developer page: <https://developer.acconeer.com/>

Below a system overview is shown:

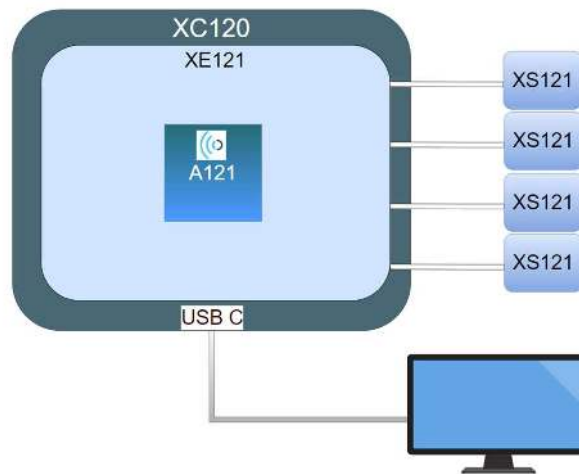

---

<sup>1</sup> Acconeer’s “Exploration Tool” is supported by Linux and Windows OS.

## 2. XC120 Evaluation Board.

### 2.1 Overview

The purpose of the XC120 board is to act as a high-speed USB bridge to the A121 Pulsed Coherent Radar Sensor Evaluation Board XE121. The XC120 does NOT contain an A121 radar sensor and is intended to be used together with XE121. Without the XE121, XC120 serves no purpose.

The XC120 board carries a cortex M7 MCU to stream radar sensor data from XE121 to Acconeer’s “Exploration Tool” via USB HS 2.0. This board is intended to be used for streaming sensor data only and after flashing, no further configuration by the user is expected. The XC120 is delivered with a bootloader so that it can be flashed via the USB interface. For details on how to flash the XC120, refer to the “A121 EVK Getting Started Guide”. The XC120 is connected to XE121 via pin headers. The XE121 is designed to be compatible with STM Nucleo-64 and STM Nucleo-144 Development boards and thus the pin headers on XC120 are placed in the same way. The XC120 is however NOT a Nucleo development board and is not intended to be flashed with any SW not provided by Acconeer.

Picture 1 shows the block diagram of the XC120 Connector Board.

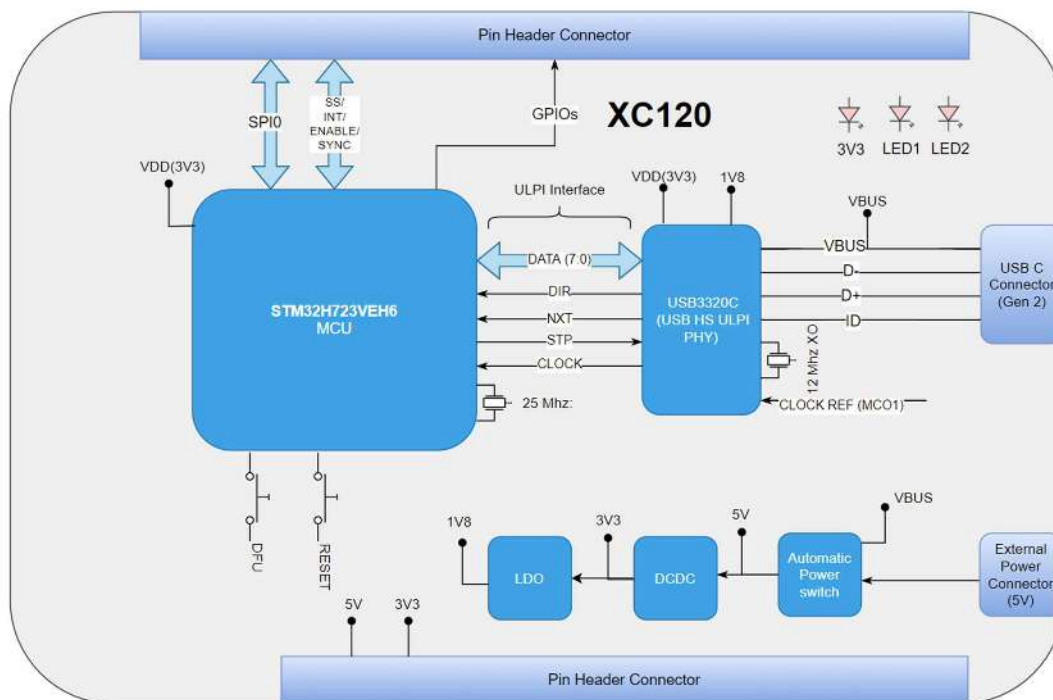

Picture 1. The block diagram of XC120.

### 2.2 Power

The XC120 connector board is powered via USB (5V, 500mA). This 5V power domain powers the complete A121 EVK (XC120+XE121+XS121). For some use cases (when attaching more than one XS121 board to XE121 and running simultaneous radar measurements on them), more power may be needed. An external power supply can then be connected via J3 (not mounted pin header). As soon as

5V is available on J3, the current is automatically drawn from the external power supply. When the power LED D1 is lit, the board is powered on and ready for use. Refer to Picture 2 for details on J3 and D1. Picture 2 and Picture 3 shows the XC120 connector board from the front and reverse sides.

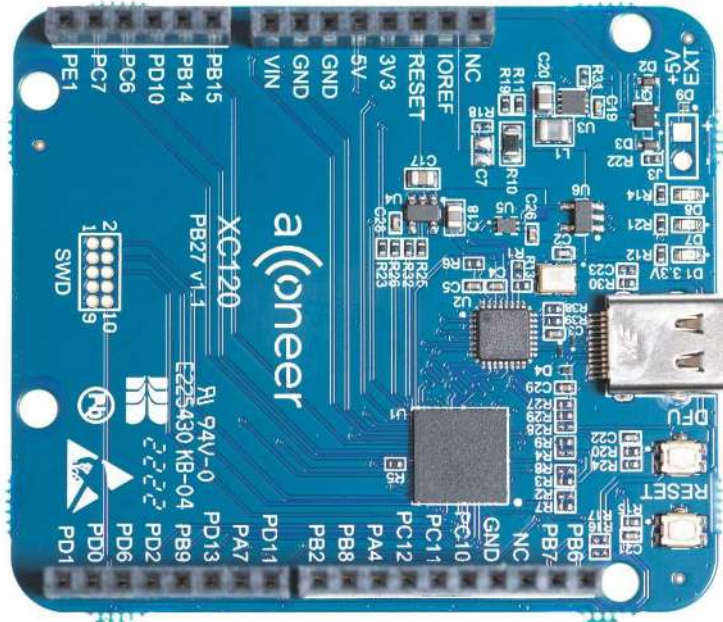

Picture 2. The XC120 front side.

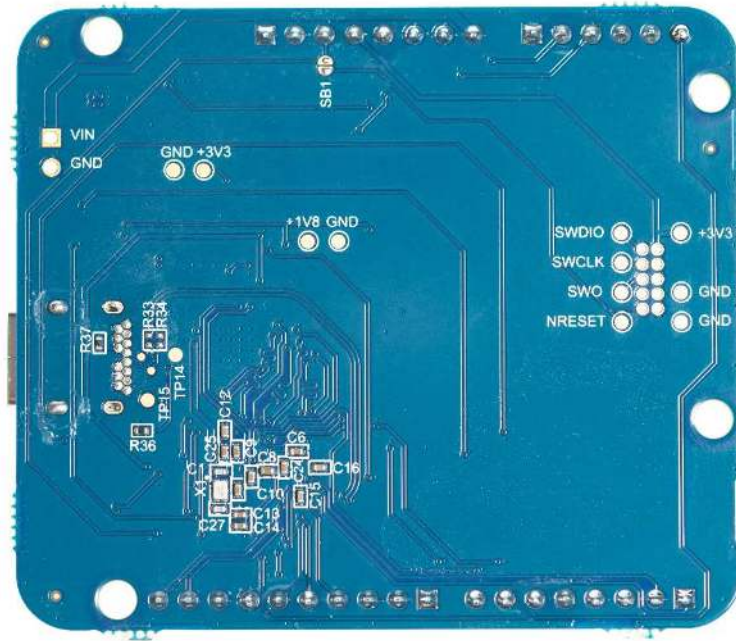

Picture 3. The XC120 reverse side.

Picture 4 shows XC120 connected to XE121 and one XS121. Picture 5 shows XC120 connected to XE121 and four XS121 (fully loaded configuration).

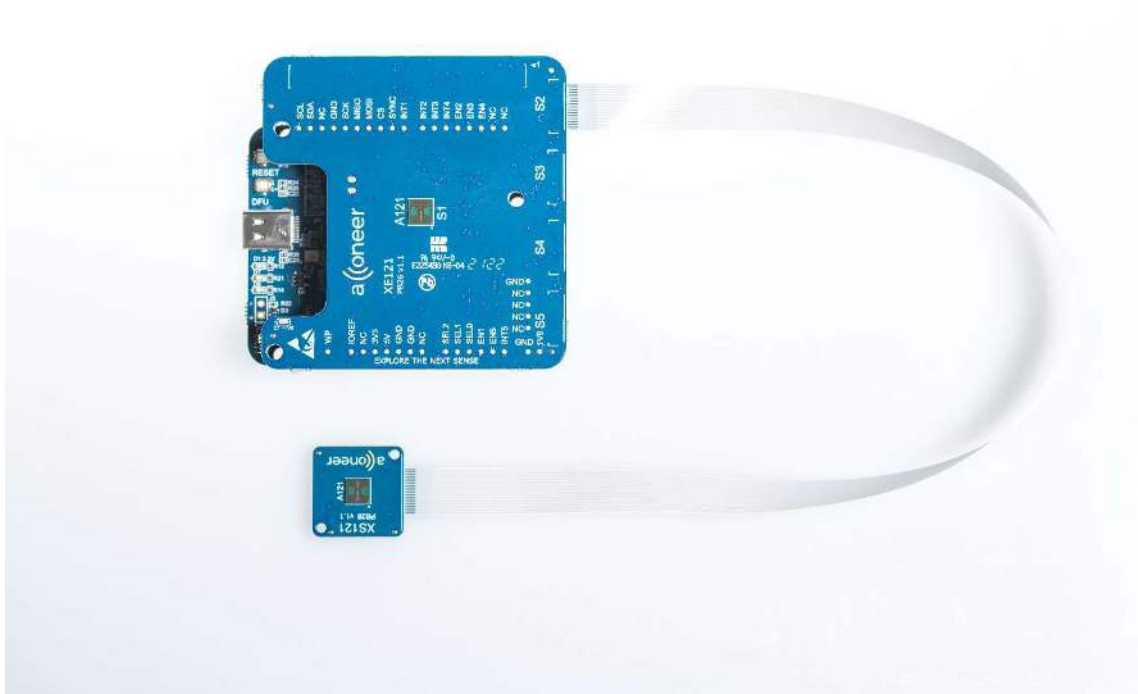

Picture 4. XC120 connected to XE121 and one XS121.

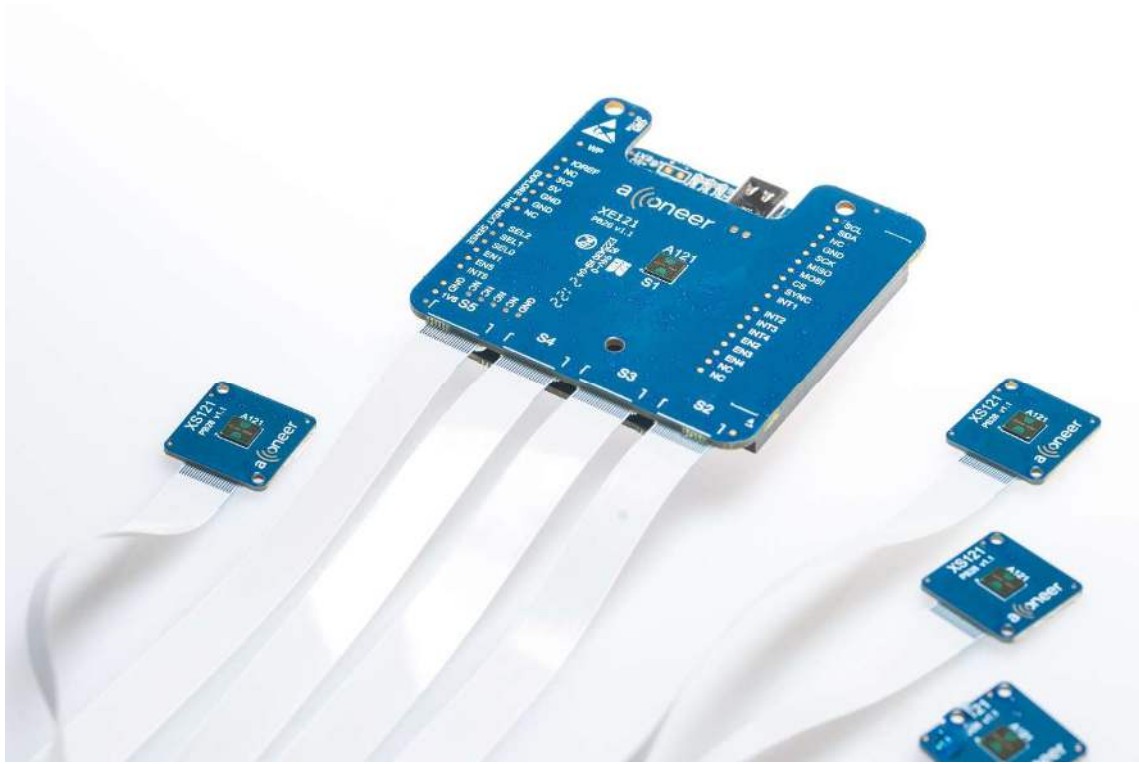

Picture 5. XC120 connected to XE121 and four XS121.



### 3. Revision History

<b>Date</b>	<b>Version</b>	<b>Changes</b>
2022-07-06	1.0	Original Version

## 4. Disclaimer

The information herein is believed to be correct as of the date issued. Acconeer AB (“**Acconeer**”) will not be responsible for damages of any nature resulting from the use or reliance upon the information contained herein. Acconeer makes no warranties, expressed or implied, of merchantability or fitness for a particular purpose or course of performance or usage of trade. Therefore, it is the user’s responsibility to thoroughly test the product in their particular application to determine its performance, efficacy and safety. Users should obtain the latest relevant information before placing orders.

Unless Acconeer has explicitly designated an individual Acconeer product as meeting the requirement of a particular industry standard, Acconeer is not responsible for any failure to meet such industry standard requirements.

Unless explicitly stated herein this document Acconeer has not performed any regulatory conformity test. It is the user’s responsibility to assure that necessary regulatory conditions are met and approvals have been obtained when using the product. Regardless of whether the product has passed any conformity test, this document does not constitute any regulatory approval of the user’s product or application using Acconeer’s product.

Nothing contained herein is to be considered as permission or a recommendation to infringe any patent or any other intellectual property right. No license, express or implied, to any intellectual property right is granted by Acconeer herein.

Acconeer reserves the right to at any time correct, change, amend, enhance, modify, and improve this document and/or Acconeer products without notice.

This document supersedes and replaces all information supplied prior to the publication hereof.

