

DO NOT SCALE FROM THIS PRINT

| TABLE 1 |                |                |                |              |               | MATED HEIGHT WITH QSE-DP-01 |
|---------|----------------|----------------|----------------|--------------|---------------|-----------------------------|
| STYLE   | "B"            | "C"            | BODY           | GROUND PLANE | TERMINAL      |                             |
| -01     | .1680 [4.267]  | .1600 [4.064]  | QTE-20-01-D-XX | T-1G1-01-XXX | T-1S39-01-XXX | .197 [5.00] REF             |
| -02     | .2861 [7.267]  | .2781 [7.064]  | QTE-20-02-D-XX | T-1G1-02-XXX | T-1S59-02-XXX | .315 [8.00] REF             |
| -03     | .4042 [10.267] | .3962 [10.063] | QTE-20-03-D-XX | T-1G1-03-XXX | T-1S39-03-XXX | .433 [11.00] REF            |

| TABLE 3   |                |               |
|-----------|----------------|---------------|
| No OF POS | "A"            | "D"           |
| -014      | .788 [20.00]   | .728 [18.48]  |
| -028      | 1.575 [40.01]  | 1.515 [38.48] |
| -042      | 2.363 [60.01]  | 2.303 [58.48] |
| -056      | 3.150 [80.01]  | 3.090 [78.49] |
| -070      | 3.938 [100.01] | 3.878 [98.49] |

| TABLE 2         |                                     |
|-----------------|-------------------------------------|
| No OF POSITIONS | COPLANARITY (INCLUDES GROUND PLANE) |
| -014 THRU -042  | .004 [0.10]                         |
| -056 THRU -070  | .006 [0.15]                         |

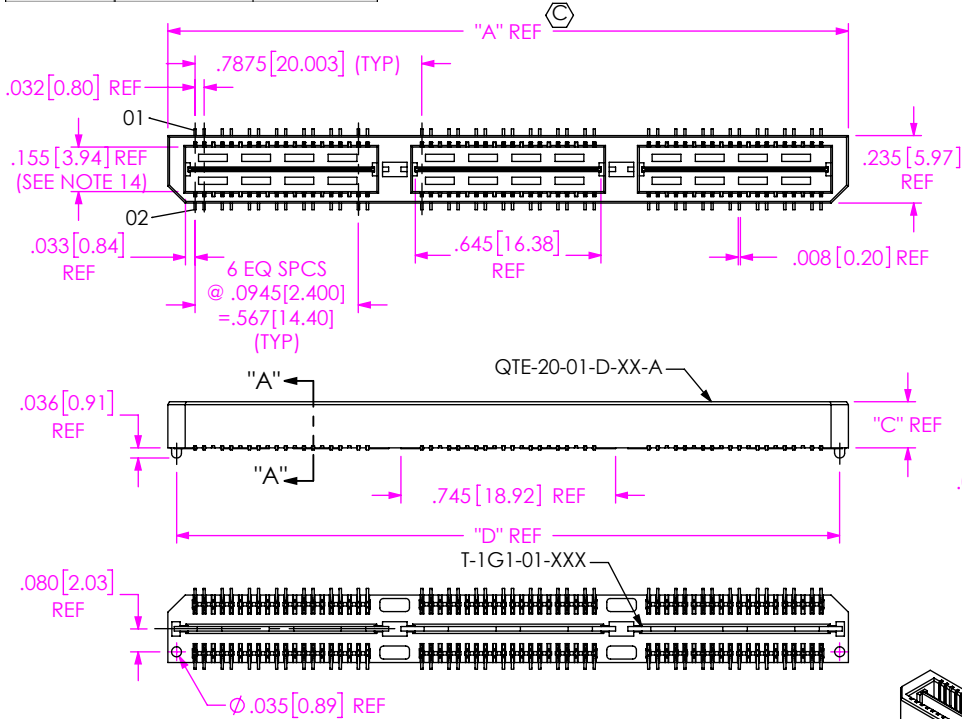

QTE-XXX-XX-XXX-D-DP-XXX-X-XX

No OF POSITIONS  
 -014, -028, -042, \*-056, \*-070 (PER ROW) (\*SEE NOTE 15)

LEAD STYLE

- 01: .1680 [4.267] (SEE FIG 1)
- 02: .2861 [7.264] (SEE FIG 1)
- 03: .4042 [10.233] (SEE FIG 1)
- 04: .600 [15.24] (SEE FIG 4, SHT 3)
- 05: .718 [18.237] (SEE FIG 4, SHT 3)
- 06: .835 [21.209] (SEE FIG 4, SHT 3)
- 07: .954 [24.232]
- 08: 1.151 [29.24]
- 09: .522 [13.258]
- 10: .5606 [14.239]

PLATING SPECIFICATION

- F: 3µ" FLASH GOLD IN CONTACT AREA, MATTE TIN ON TAIL (USE T-1SXX-XX-F, T-1G1-XX-F) (SEE NOTE 9)
- L: 10µ" LIGHT GOLD IN CONTACT AREA, MATTE TIN ON TAIL (USE T-1SXX-XX-L, T-1G1-XX-L)
- H: 30µ" HEAVY GOLD IN CONTACT AREA, 3µ" GOLD ON TAIL (USE T-1SXX-XX-H, T-1G1-XX-G)
- C: 50µ" ELECTRO-POLISHED SELECTIVE IN CONTACT AREA, MATTE TIN ON TAIL (USE T-1SXX-XX-C, T-1G1-XX-L)
- STL: 30µ" HEAVY SELECTIVE GOLD IN CONTACT AREA, TIN LEAD ON TAIL (USE T-1SXX-XX-STL, T-1G1-XX-STL)
- FTL: 3µ" FLASH SELECTIVE GOLD IN CONTACT AREA, TIN LEAD ON TAIL (USE T-1SXX-XX-FTL, T-1G1-XX-FTL)

PACKAGING  
 BLANK: TRAY (SEE NOTES 16 & 17)  
 -TR: TAPE & REEL (SEE NOTES 17 & 18)  
 -FR: FULL REEL QTY TAPE & REEL (SEE NOTES 17 & 18)

PICK & PLACE OPTION

- K: POLYIMIDE FILM (USE K-DOT-.276-.375-.005) (SEE FIG 3, SHT 2) (N/A ON STYLES -07 & -08)

OPTION

- A: ALIGNMENT PINS
- LC: LOCKING CLIPS (SEE NOTE 13) (USE LC-08-TM-01) (SEE FIG 2, SHT 2)
- GP: GUIDE POSTS (AVAILABLE ON -01 ONLY) (USE QTE-20-01-D-XX-X-GP) (SEE FIG 4, SHT 3)
- RT1: RETENTION OPTION (SEE FIG 9, SHT 5) (ONLY AVAILABLE ON -01 LEAD STYLE) (MUST USE -A OPTION) (USE QTE-20-01-D-XX-A-RT1 & T-1R36-01-F) (NOT AVAILABLE WITH -LC, -GP, OR -L) (NOT AVAILABLE ON -056 & -070 POS)
- L: LATCHING OPTION (28 POS. MAX.) (SEE FIG 10, SHT 5) (MUST USE -A OPTION) (AVAILABLE ON -01 ONLY) (NOT AVAILABLE WITH -LC, -GP, OR -RT1)

BODY STYLE

- DP: DIFFERENTIAL PAIRS

ROW SPECIFICATION

- D: DOUBLE (USE QTE-20-XX-D:XX & QTEH-20-XX-D-XX)

No OF BANKS

◇ = ASO ONLY (APPLICATION SPECIFIC ORDER)

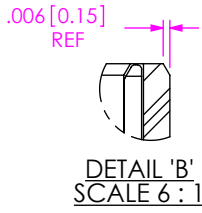

T-1SXX-XX-XXX (SEE TABLE 1)

⊕ .155<sup>+0.03</sup><sub>-.005</sub> [3.94<sup>+0.08</sup><sub>-0.11</sub>] (SEE NOTE 14)

⊕ "B"<sup>+0.03</sup><sub>-.002</sub> [0.05] (SEE NOTE 5, 6 & 10)

⊕ SEE TABLE 2 (SEE NOTE 10)

.035 [0.90] REF  
.015 [0.38] REF

.280 [7.11]

SECTION "A"- "A"

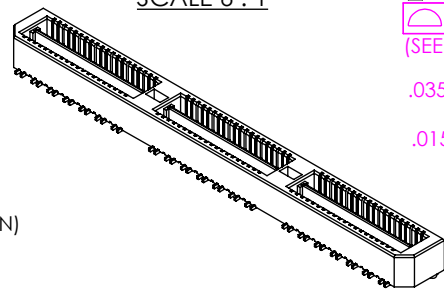

NOTES:

1. ⊕ REPRESENTS A CRITICAL DIMENSION.
2. MINIMUM TERMINAL RETENTION: 5 OZ.
3. MINIMUM GROUND PLANE RETENTION: 1 LB
4. PARTS TO BE MOLDED TO POSITION.
5. MAXIMUM VARIANCE OF .002 [0.05]
6. DIMENSION APPLIES TO TERMINALS AND GROUND PLANE.
7. DELETED.
8. DELETED.
9. -L PLATING CAN BE SUBSTITUTED FOR -F PLATING.
10. GROUND PLANE PRESS HEIGHT MUST BE .003[0.08] LESS THAN THE MAX HEIGHT OR .001[0.03] GREATER THAN THE MINIMUM HEIGHT OF THE TERMINALS.
11. T-1R36 RETENTION TO BODY TO BE 1.0 LBF.
12. NOTE DELETED.
13. DUE TO THE HIGH AMOUNT OF INSERTION FORCE NEEDED, THE -LC OPTION IS NOT COMPATIBLE WITH AUTO PLACEMENT. SAMTEC RECOMMENDS MANUAL PLACEMENT FOR ALL ASSEMBLIES WITH THE -LC OPTION.
- ⊕ 14. MAXIMUM PIN CAN EXTEND PAST WALL: .003[0.08].
15. AVAILABLE FOR EXISTING CUSTOMERS ONLY.
16. TRAYS ARE STANDARD PACKAGING.
17. ORDERS WILL BE PACKAGED ACCORDING TO THE SAMTEC PACKAGING EFFICIENCY STANDARDS (SPES) FOUND ON WWW.SAMTEC.COM.
18. ATTACH LABEL -4X2 TO EACH REEL.

FIG 1

-A: ALIGNMENT PIN OPTION (QTE-042-01-XXX-D-DP-A SHOWN) (STYLE -01, -02 & -03 ONLY)

UNLESS OTHERWISE SPECIFIED, DIMENSIONS ARE IN INCHES.  
 TOLERANCES ARE:  
 DECIMALS ANGLES  
 .XX: ±.01 [3]  
 .XXX: ±.005 [13]  
 .XXXX: ±.0020 [051]

PROPRIETARY NOTE

THIS DOCUMENT CONTAINS CONFIDENTIAL AND PROPRIETARY INFORMATION AND ALL DESIGN, MANUFACTURING, REPRODUCTION, USE, PATENT RIGHTS AND SALES RIGHTS ARE EXPRESSLY RESERVED BY SAMTEC, INC. THIS DOCUMENT SHALL NOT BE DISCLOSED, IN WHOLE OR PART, TO ANY UNAUTHORIZED PERSON OR ENTITY NOR REPRODUCED, TRANSFERRED OR INCORPORATED IN ANY OTHER PROJECT IN ANY MANNER WITHOUT THE EXPRESS WRITTEN CONSENT OF SAMTEC, INC.



520 PARK EAST BLVD. NEW ALBANY, IN 47150  
 PHONE: 812-944-6733 FAX: 812-948-5047  
 e-Mail: info@SAMTEC.com code 55322

MATERIAL: DO NOT SCALE DRAWING SHEET SCALE: 1.5:1

INSULATOR: LCP, UL94V-0; COLOR: BLACK  
 TERMINAL: PHOS BRONZE  
 GROUND PLANE: PHOS BRONZE

DESCRIPTION: .8mm DIFFERENTIAL PAIRS HS TERMINAL ASSEMBLY

DWG. NO. QTE-XXX-XX-XXX-D-DP-XXX-X-XX

BY: DEAN P 4/28/2000 SHEET 1 OF 5

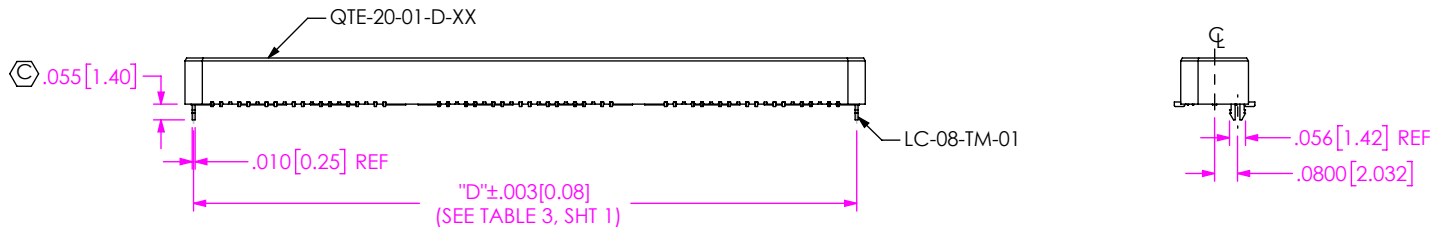

FIG 2  
 -LC: LOCKING CLIP OPTION  
 (QTS-042-01-XXX-D-DP-LC SHOWN)  
 (DIFFERENT AS SHOWN, OTHERWISE SAME AS FIG 1)

| No OF POS | "R"            |                |               |               | "S"           |               |               |              |
|-----------|----------------|----------------|---------------|---------------|---------------|---------------|---------------|--------------|
|           | -LC, -A, -FL   | -GP, -SD       | -RT1          | -L            | -LC, -A, -FL  | -GP, -SD      | -RT1          | -L           |
| -014      | .788 [20.00]   | 1.305 [33.15]  | 1.438 [36.53] | .906 [23.00]  | .256 [6.50]   | .515 [13.07]  | .581 [14.76]  | .315 [7.99]  |
| -028      | 1.575 [40.01]  | 2.093 [53.15]  | 2.226 [56.53] | 1.693 [43.00] | .650 [16.50]  | .908 [23.07]  | .975 [24.76]  | .709 [18.00] |
| -042      | 2.363 [60.01]  | 2.880 [73.15]  | 3.013 [76.53] | N/A           | 1.043 [26.50] | 1.302 [33.07] | 1.369 [34.76] | N/A          |
| -056      | 3.150 [80.01]  | 3.668 [93.15]  | N/A           | N/A           | 1.437 [36.50] | 1.696 [43.07] | N/A           | N/A          |
| -070      | 3.938 [100.01] | 4.455 [113.16] | N/A           | N/A           | 1.831 [46.50] | 2.090 [53.07] | N/A           | N/A          |

| STYLE | "T"         |
|-------|-------------|
| -01   | .173[4.39]  |
| -02   | .291[7.39]  |
| -03   | .409[10.39] |
| -04   | .605[15.37] |
| -05   | .723[18.36] |
| -06   | .841[21.36] |
| -09   | .527[13.39] |
| -10   | .567[14.37] |

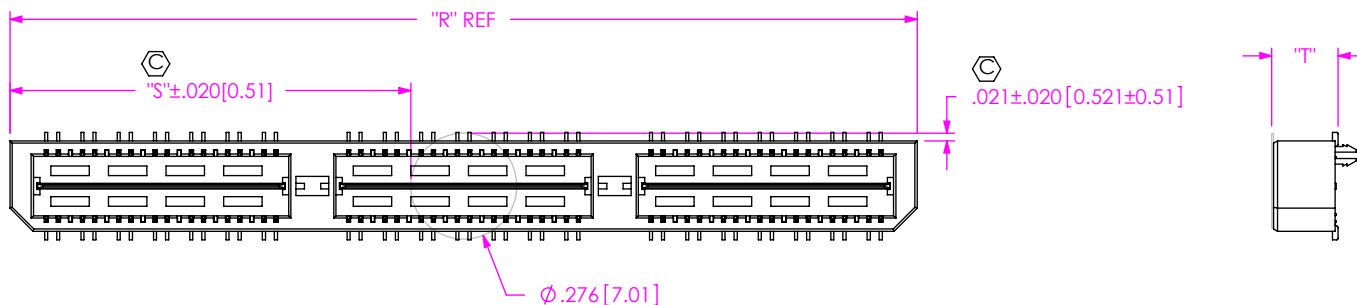



FIG 3  
 -K: POLYIMIDE FILM PAD  
 (USE K-DOT-.276-.375-.005)

|  |   |   |
|--|---|---|
| <p>PROPRIETARY NOTE</p> <p>THIS DOCUMENT CONTAINS CONFIDENTIAL AND PROPRIETARY INFORMATION AND ALL DESIGN, MANUFACTURING, REPRODUCTION, USE, PATENT RIGHTS AND SALES RIGHTS ARE EXPRESSLY RESERVED BY SAMTEC, INC. THIS DOCUMENT SHALL NOT BE DISCLOSED, IN WHOLE OR PART, TO ANY UNAUTHORIZED PERSON OR ENTITY NOR REPRODUCED, TRANSFERRED OR INCORPORATED IN ANY OTHER PROJECT IN ANY MANNER WITHOUT THE EXPRESS WRITTEN CONSENT OF SAMTEC, INC.</p> |  <p>520 PARK EAST BLVD, NEW ALBANY, IN 47150<br/>                 PHONE: 812-944-6733 FAX: 812-948-5047<br/>                 e-Mail info@SAMTEC.com code 55322</p> |   |
|  | <p>DESCRIPTION:<br/>                 .8mm DIFFERENTIAL PAIRS HS TERMINAL ASSEMBLY</p>   |   |
|  | <p>DO NOT SCALE DRAWING</p> <p>SHEET SCALE: 2:1</p>   | <p>DWG. NO.<br/>                 QTE-XXX-XX-XXX-D-DP-XXX-X-XX</p> |
| <p>BY: DEAN P 4/28/2000 SHEET 2 OF 5</p>   |   |   |

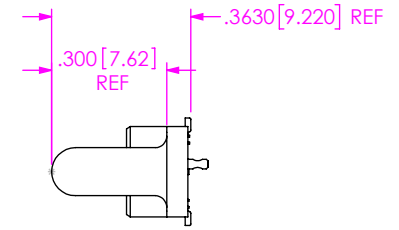
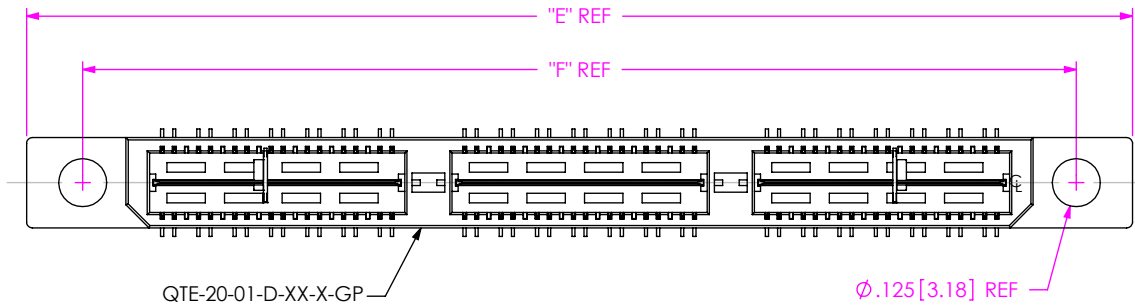

FIG 4  
 -GP: GUIDE POST OPTION  
 (QTE-042-01-XXX-D-DP-GP SHOWN)  
 (DIFFERENT AS SHOWN, OTHERWISE SAME AS FIG 1)  
 (AVAILABLE ON STYLE -01 ONLY)

| POS  | "E"            | "F"            |
|------|----------------|----------------|
| -014 | 1.305 [33.15]  | 1.013 [25.72]  |
| -028 | 2.093 [53.15]  | 1.800 [45.72]  |
| -042 | 2.880 [73.15]  | 2.588 [65.72]  |
| -56  | 3.668 [93.15]  | 3.375 [85.73]  |
| -070 | 4.455 [113.16] | 4.163 [105.73] |

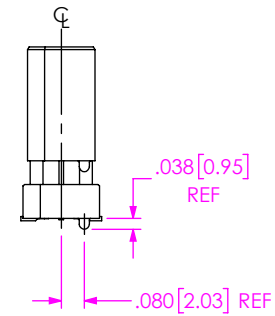
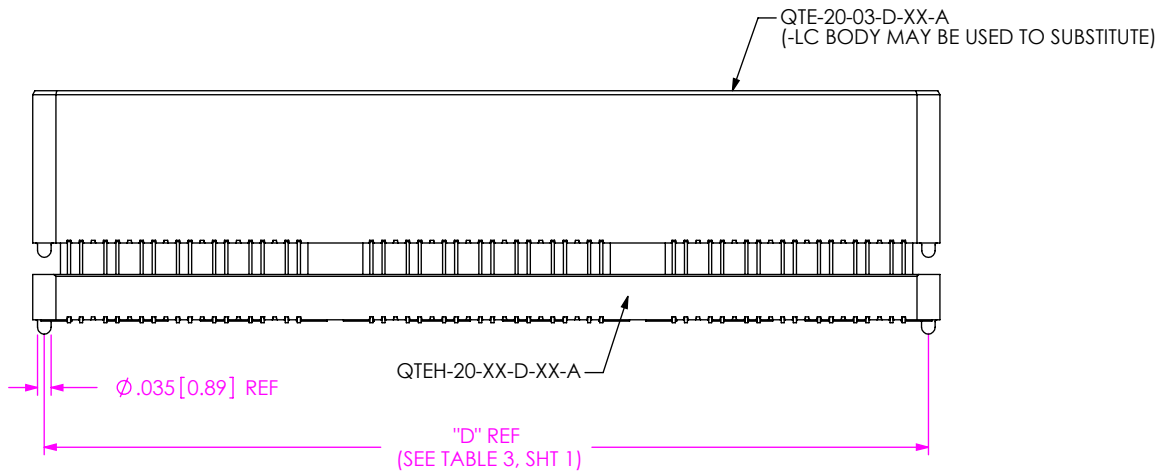

FIG 5  
 (QTE-020-04-XXX-D-A SHOWN)  
 (DIFFERENT AS SHOWN, OTHERWISE SAME AS FIG 1)  
 (STYLES -04, -05, -06, -07, -08, -09 & -10, SEE TABLE 7, SHT 4)

**PROPRIETARY NOTE**  
 THIS DOCUMENT CONTAINS CONFIDENTIAL AND PROPRIETARY INFORMATION AND ALL DESIGN, MANUFACTURING, REPRODUCTION, USE, PATENT RIGHTS AND SALES RIGHTS ARE EXPRESSLY RESERVED BY SAMTEC, INC. THIS DOCUMENT SHALL NOT BE DISCLOSED, IN WHOLE OR PART, TO ANY UNAUTHORIZED PERSON OR ENTITY NOR REPRODUCED, TRANSFERRED OR INCORPORATED IN ANY OTHER PROJECT IN ANY MANNER WITHOUT THE EXPRESS WRITTEN CONSENT OF SAMTEC, INC.



520 PARK EAST BLVD., NEW ALBANY, IN 47150  
 PHONE: 812-944-6733 FAX: 812-948-5047  
 e-Mail: info@SAMTEC.com code 55322

DO NOT SCALE DRAWING

SHEET SCALE: 2:1

DESCRIPTION:  
 .8mm DIFFERENTIAL PAIRS HS TERMINAL ASSEMBLY

DWG. NO.  
 QTE-XXX-XX-XXX-D-DP-XXX-X-XX

BY: DEAN P 4/28/2000 SHEET 3 OF 5

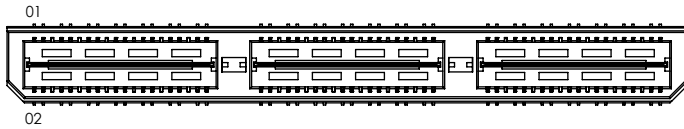

| TABLE 7 |               |               |               |                  |                   | MATED HEIGHT WITH QSE-DP-01 |
|---------|---------------|---------------|---------------|------------------|-------------------|-----------------------------|
| STYLE   | "B"           | GROUND PLANE  | TERMINAL      | FILLER BODY      | SPACER BODY       |                             |
| -04     | .600[15.24]   | T-1G1-04-XXX  | T-1S41-04-XXX | QTE-20-03-D-XX   | QTEH-20-01-D-XX-X | .630 [16.00] REF            |
| -05     | .718[18.237]  | T-1G1-05-XXX  | T-1S41-05-XXX | QTE-20-03-D-XX   | QTEH-20-01-D-XX-X | .748 [19.00] REF            |
| -06     | .835[21.209]  | T-1G1-06-XXX  | T-1S41-06-XXX | QTE-20-03-D-XX   | QTEH-20-02-D-XX-X | .866 [22.00] REF            |
| -07     | .954[24.232]  | T-1G17-01-XXX | T-1S61-21-XXX | QTE-20-02-D-XX-X | QTEH-20-04-D-XX-X | .984 [25.00] REF            |
| -08     | 1.151[29.24]  | T-1G17-02-XXX | T-1S61-22-XXX | QTE-20-02-D-XX-X | QTEH-20-04-D-XX-X | 1.181 [30.00] REF           |
| -09     | .522[13.259]  | T-1G1-09-XXX  | T-1S60-09-XXX | QTE-20-02-D-XX-X | QTEH-20-01-D-XX-X | .551[14.00] REF             |
| -10     | .5606[14.239] | T-1G1-10-XXX  | T-1S60-10-XXX | QTE-20-02-D-XX-X | QTEH-20-01-D-XX-X | .591[15.00] REF             |

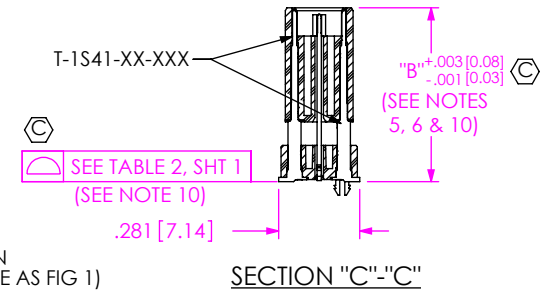
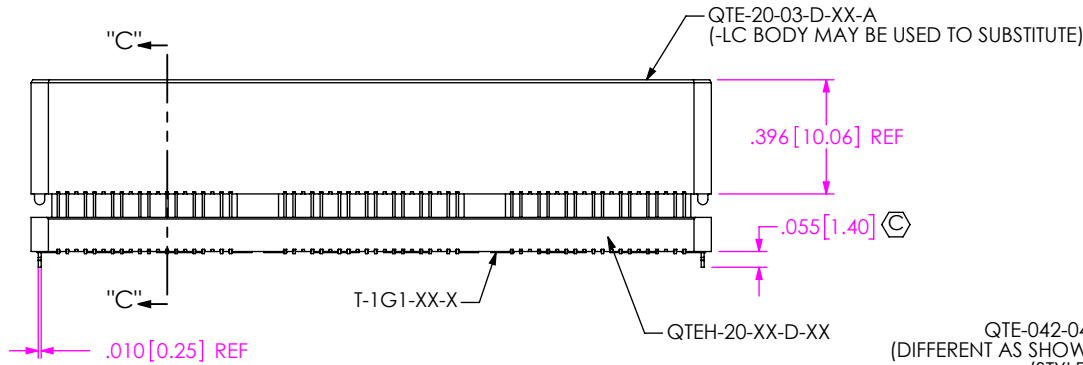

FIG 6  
QTE-042-04-X-D-DP-LC SHOWN  
(DIFFERENT AS SHOWN, OTHERWISE SAME AS FIG 1)  
(STYLES -04, -05 & -06)

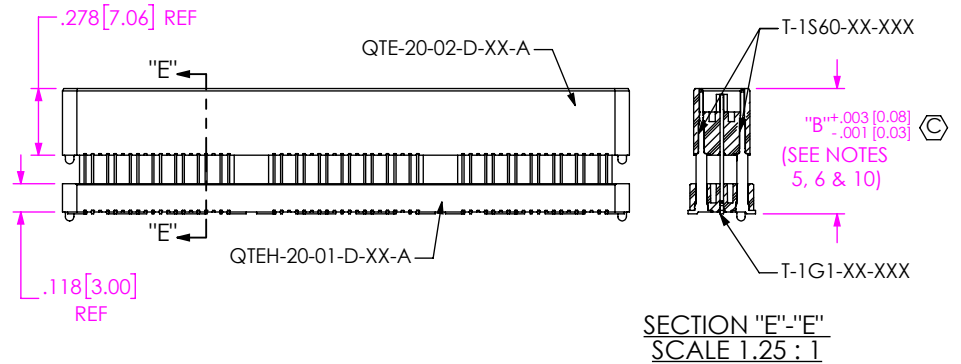
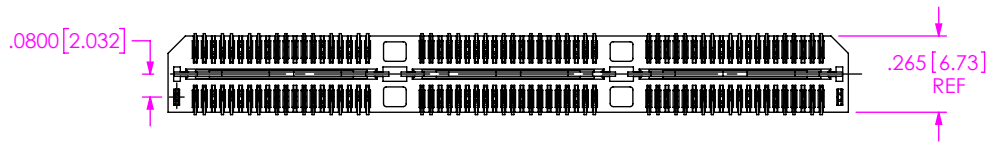

FIG 8  
QTE-042-09-X-D-DP-A SHOWN  
(DIFFERENT AS SHOWN, OTHERWISE SAME AS FIG 6)  
(STYLES -09 & -10)

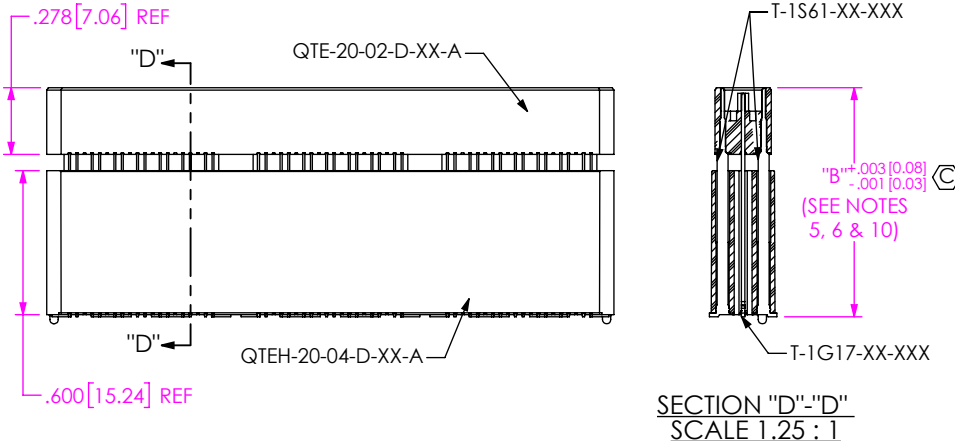
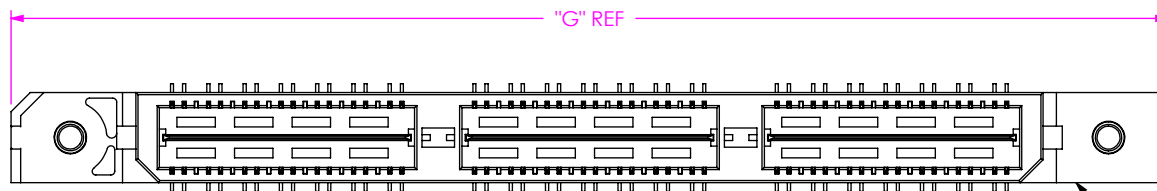

FIG 7  
QTE-042-07-X-D-DP-A SHOWN  
(DIFFERENT AS SHOWN, OTHERWISE SAME AS FIG 6)  
(STYLES -07 & -08)

c:\enterprisevault\DWG\MISC\MKTG\QTE-XXX-XX-XXX-D-DP-XXX-X-XX-MKT.SLDDRW

|   |   |   |
|---|---|---|
| <p>DO NOT SCALE DRAWING</p> <p>SHEET SCALE: 1.5:1</p> | <p><b>PROPRIETARY NOTE</b></p> <p>THIS DOCUMENT CONTAINS CONFIDENTIAL AND PROPRIETARY INFORMATION AND ALL DESIGN, MANUFACTURING, REPRODUCTION, USE, PATENT RIGHTS AND SALES RIGHTS ARE EXPRESSLY RESERVED BY SAMTEC, INC. THIS DOCUMENT SHALL NOT BE DISCLOSED, IN WHOLE OR PART, TO ANY UNAUTHORIZED PERSON OR ENTITY NOR REPRODUCED, TRANSFERRED OR INCORPORATED IN ANY OTHER PROJECT IN ANY MANNER WITHOUT THE EXPRESS WRITTEN CONSENT OF SAMTEC, INC.</p> | <p>520 PARK EAST BLVD, NEW ALBANY, IN 47150<br/>PHONE: 812-944-6733 FAX: 812-948-5047<br/>e-Mail info@SAMTEC.com code 55322</p> |
|   | <p>DESCRIPTION:<br/>.8mm DIFFERENTIAL PAIRS HS TERMINAL ASSEMBLY</p>  |   |
|   | <p>DWG. NO.<br/>QTE-XXX-XX-XXX-D-DP-XXX-X-XX</p>  |   |
| <p>BY: DEAN P 4/28/2000</p>                           | <p>SHEET 4 OF 5</p>   |   |

| TABLE 8 |               |               |
|---------|---------------|---------------|
| POS     | "G"           | "H"           |
| -014    | 1.438 [36.53] | 1.129 [28.68] |
| -028    | 2.226 [56.53] | 1.917 [48.68] |
| -042    | 3.013 [76.53] | 2.704 [68.68] |
| -056    | N/A           | N/A           |
| -070    | N/A           | N/A           |



QTE-20-01-D-XX-A-RT1

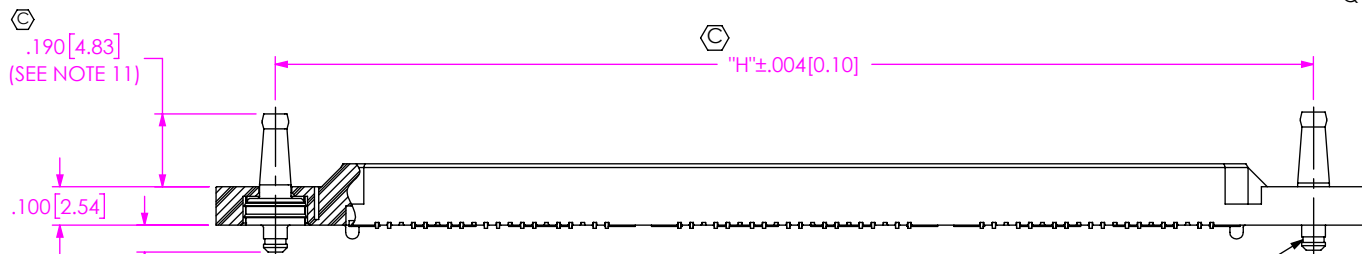

**FIG 9**  
 -RT1: RETENTION OPTION  
 (QTE-042-01-XXX-D-DP-A-RT1 SHOWN)  
 (DIFFERENT AS SHOWN, OTHERWISE SAME AS FIG 1)  
 (ONLY AVAILABLE ON -01 LEAD STYLE) (MUST USE -A OPTION)  
 (NOT AVAILABLE WITH -LC, -GP, OR -L OPTIONS)  
 (NOT AVAILABLE ON -056 & -070 POSITIONS)

T-1R36-01-F (2 PLCS)

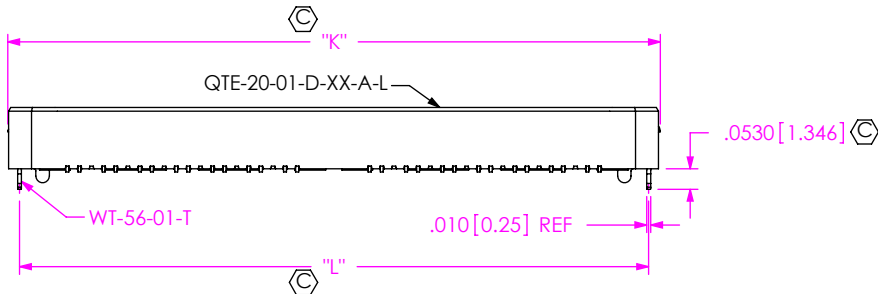
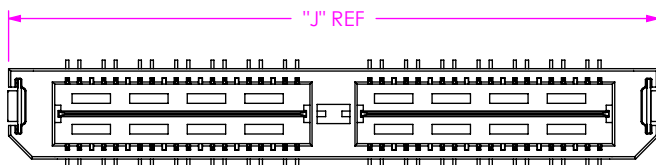

**FIG 10**  
 -L: LATCHING OPTION  
 (QTE-028-01-XXX-D-DP-A-L SHOWN)  
 (DIFFERENT AS SHOWN, OTHERWISE SAME AS FIG 1)  
 (28 POS MAX) (MUST USE -A OPTION)  
 (AVAILABLE ON -01 LEAD STYLE ONLY)  
 (NOT AVAILABLE WITH -LC, -GP, OR -RT1)

| TABLE 9 |               |               |               |
|---------|---------------|---------------|---------------|
| POS     | "J"           | "K"           | "L"           |
| -014    | .906 [23.00]  | .915 [23.24]  | .854 [21.69]  |
| -028    | 1.693 [43.00] | 1.703 [43.24] | 1.642 [41.69] |
| -042    | N/A           | N/A           | N/A           |
| -056    | N/A           | N/A           | N/A           |
| -070    | N/A           | N/A           | N/A           |

| CRITICAL DIMENSION INSPECTION INSTRUCTION TABLE |                              |
|---|------------------------------|
| ASSEMBLY OPERATION                              | IN PROCESS INSPECTION        |
| FILL T-1SXX                                     | C1, C2, C3, C4, C5, C11, C12 |
| FILL GROUND PLANE T-1G1                         | C4                           |
| ADD -LC OPTION                                  | C13                          |
| ADD -RT1 OPTION                                 | C6, C7                       |
| ADD -L OPTION                                   | C8, C9, C10                  |
| ADD -K OPTION                                   | C14, C15                     |

**PROPRIETARY NOTE**  
 THIS DOCUMENT CONTAINS CONFIDENTIAL AND PROPRIETARY INFORMATION AND ALL DESIGN, MANUFACTURING, REPRODUCTION, USE, PATENT RIGHTS AND SALES RIGHTS ARE EXPRESSLY RESERVED BY SAMTEC, INC. THIS DOCUMENT SHALL NOT BE DISCLOSED, IN WHOLE OR PART, TO ANY UNAUTHORIZED PERSON OR ENTITY NOR REPRODUCED, TRANSFERRED OR INCORPORATED IN ANY OTHER PROJECT IN ANY MANNER WITHOUT THE EXPRESS WRITTEN CONSENT OF SAMTEC, INC.



520 PARK EAST BLVD, NEW ALBANY, IN 47150  
 PHONE: 812-944-6733 FAX: 812-948-5047  
 e-Mail info@SAMTEC.com code 53322

DO NOT SCALE DRAWING

SHEET SCALE: 2:1

DESCRIPTION:  
 .8mm DIFFERENTIAL PAIRS HS TERMINAL ASSEMBLY

DWG. NO.  
**QTE-XXX-XX-XXX-D-DP-XXX-X-XX**

BY: DEAN P 4/28/2000 SHEET 5 OF 5