

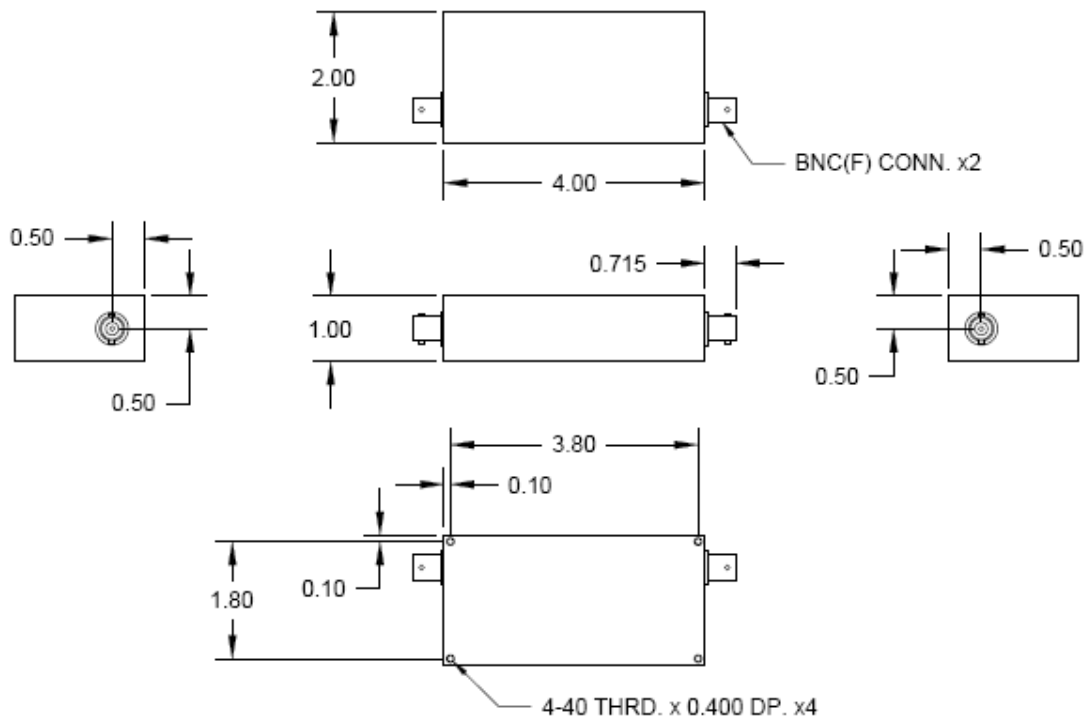

3.10 MHz Bandpass Filter

P/N: AE3.10B10718

| | |
|--|----------------|
| Center Frequency: | 3.10 MHz |
| Nominal 3 dB BW: | 270,000 |
| 1 dB BW: | 189,000 Hz min |
| 40 dB to 3 dB Shape Factor: | 2.0:1 |
| Nominal 40 dB BW: | 540000 |
| VSWR: | 1.5:1 max |
| P-P Ripple in 1 dB BW: | 0.5 dB |
| Suppression in the 0-20 MHz Band outside filters 40 dB BW: | 40 dB |
| Input/Output Impedance: | 50 Ohms |
| I/O Connectors: | BNC (F) |
| Max Input Power: | 0.5 W |
| Max Insertion Loss: | 10 dB |
| Operating Temperature Range: | 15°C to 40°C |
| Shock: | 1G |
| Vibration: | 1G |





3.10 MHz Bandpass Filter

P/N: AE3.10B10718

