

Description

The 9ZX1251 meets the demanding requirements of the Intel DB1200ZL specification, including the critical low-drift requirements of Intel CPUs. It is pin compatible to the 9ZX1231 and integrates 24 termination resistors, saving 41mm² board area.

Applications

Buffer for Romley, Grantley and Purley Servers, solid state storage and PCIe

Output Features

- 12 LP-HCSL Output Pairs w/integrated terminations ($Z_o = 85\Omega$)

Key Specifications

- Cycle-to-cycle jitter < 50ps
- Output-to-output skew < 50ps
- Input-to-output delay variation < 50ps
- PCIe Gen3 phase jitter < 1.0ps RMS
- Phase jitter: QPI/UPI > = 9.6GB/s < 0.2ps rms

Features

- 25MHz PFT clock delay management
- 85Ω Low-power push-pull HCSL outputs; eliminate 24 resistors, save 41mm² of area
- Pin compatible to 9ZX21201 and 9ZX1231; easy path to power and area savings
- Space-saving 64-pin VFQFPN package
- Fixed feedback path for 0ps input-to-output delay
- 9 selectable SMBus addresses; multiple devices can share the same SMBus segment
- 12 OE# pins; hardware control of each output
- PLL or bypass mode; supports common and separate clock architectures
- Selectable PLL bandwidth; minimizes jitter peaking in downstream PLLs
- Spread spectrum compatible; tracks spreading input clock for low EMI
- -40°C to +85°C device available; supports demanding environmental applications

Block Diagram

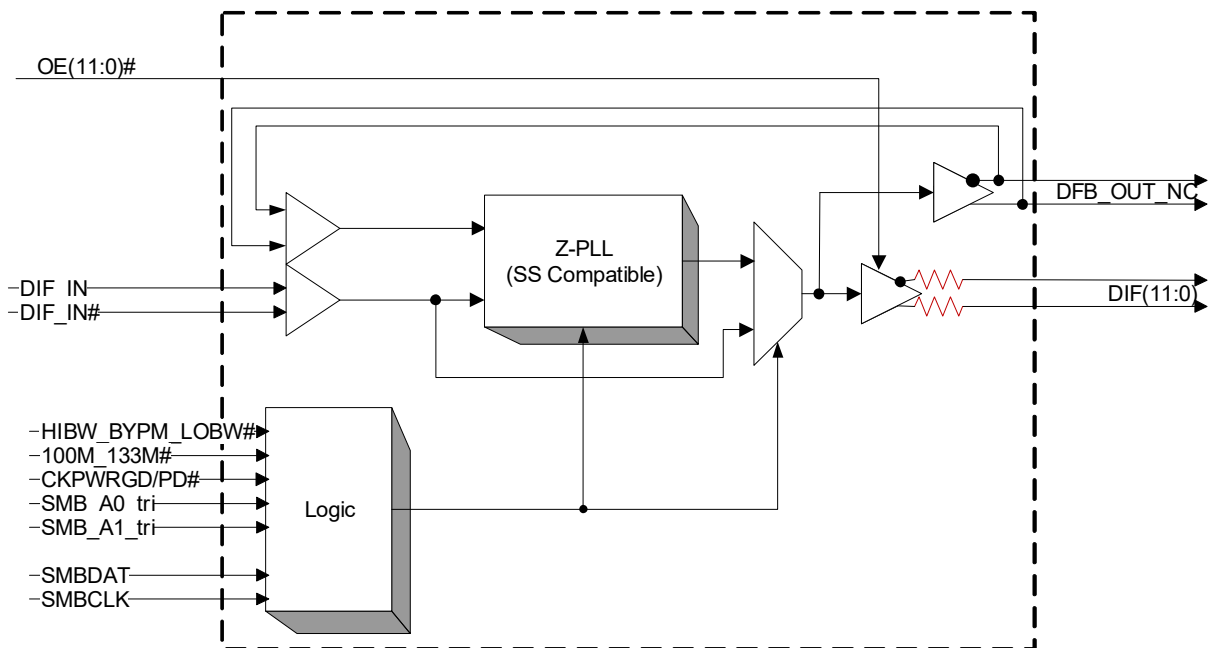

Pin Configuration

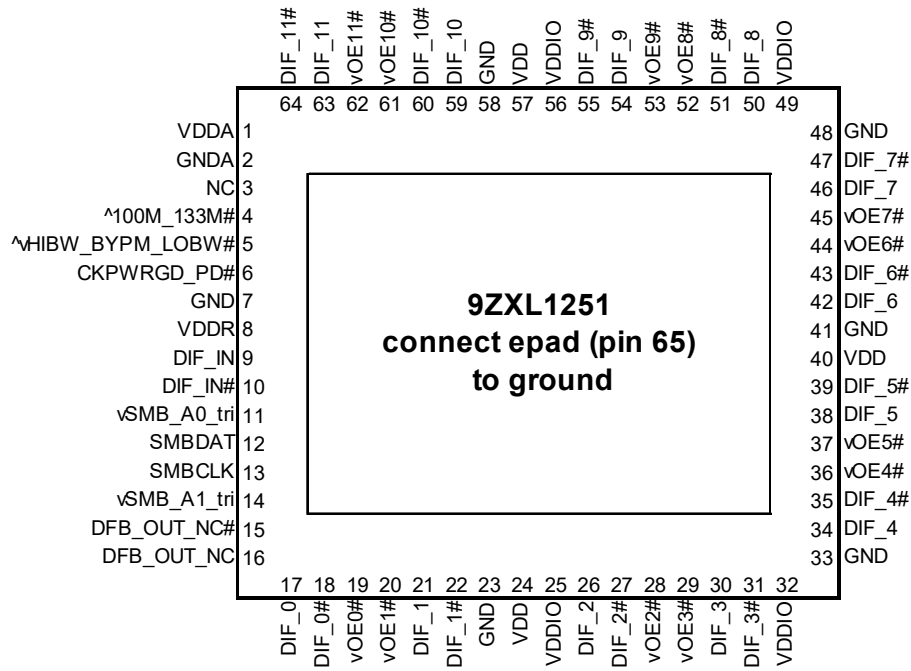

9 x 9mm VFQFPN package

Note: Pins with ^ prefix have internal 120K pullup
 Pins with v prefix have internal 120K pulldown
 Pins with ^v prefix have internal 120K pullup/pulldown (biased to VDD/2)

Power Management Table

CKPWRGD_PD#	DIF_IN/ DIF_IN#	SMBus EN bit	DIF(11:0)/ DIF(11:0)#	PLL STATE IF NOT IN BYPASS MODE
0	X	X	Low/Low	OFF
1	Running	0	Low/Low	ON
		1	Running	ON

Functionality at Power-up (PLL mode)

100M_133M#	DIF_IN MHz	DIF(11:0)
1	100.00	DIF_IN
0	133.33	DIF_IN

Power Connections

Pin Number			Description
VDD	VDDIO	GND	
1		2	Analog PLL
8		7	Analog Input
24,40,57	25,32,49,56	23,33,41,48, 58,65	DIF clocks

PLL Operating Mode Readback Table

HiBW_BypM_LoBW#	Byte0, bit 7	Byte 0, bit 6
Low (Low BW)	0	0
Mid (Bypass)	0	1
High (High BW)	1	1

PLL Operating Mode

HiBW_BypM_LoBW#	MODE
Low	PLL Lo BW
Mid	Bypass
High	PLL Hi BW

NOTE: PLL is OFF in Bypass Mode

9ZXL1251 SMBus Addressing

Pin		
SMB_A1_tri	SMB_A0_tri	SMBus Address
0	0	D8
0	M	DA
0	1	DE
M	0	C2
M	M	C4
M	1	C6
1	0	CA
1	M	CC
1	1	CE

Pin Descriptions

PIN #	PIN NAME	TYPE	DESCRIPTION
1	VDDA	PWR	Power for the PLL core.
2	GNDA	GND	Ground pin for the PLL core.
3	NC	N/A	No Connection.
4	^100M_133M#	IN	3.3V Input to select operating frequency. This pin has an internal pull-up resistor. See Functionality Table for Definition
5	^vHIBW_BYPM_LOBW#	LATCHED IN	Trilevel input to select High BW, Bypass or Low BW mode. This pin is biased to VDD/2 (Bypass mode) with internal pull up/pull down resistors. See PLL Operating Mode Table for
6	CKPWRGD_PD#	IN	3.3V Input notifies device to sample latched inputs and start up on first high assertion, or exit Power Down Mode on subsequent assertions. Low enters Power Down Mode.
7	GND	GND	Ground pin.
8	VDDR	PWR	3.3V power for differential input clock (receiver). This VDD should be treated as an analog power rail and filtered appropriately.
9	DIF_IN	IN	HCSL True input
10	DIF_IN#	IN	HCSL Complementary Input
11	vSMB_A0_tri	IN	SMBus address bit. This is a tri-level input that works in conjunction with the SMB_A1 to decode 1 of 9 SMBus Addresses. It has an internal 120Kohm pull down resistor.
12	SMBDAT	I/O	Data pin of SMBUS circuitry, 5V tolerant
13	SMBCLK	IN	Clock pin of SMBUS circuitry, 5V tolerant
14	vSMB_A1_tri	IN	SMBus address bit. This is a tri-level input that works in conjunction with the SMB_A0 to decode 1 of 9 SMBus Addresses. It has an internal 120Kohm pull down resistor.
15	DFB_OUT_NC#	OUT	Complementary half of differential feedback output, provides feedback signal to the PLL for synchronization with input clock to eliminate phase error. This pin should NOT be connected on the circuit board, the feedback is internal to the package.
16	DFB_OUT_NC	OUT	True half of differential feedback output, provides feedback signal to the PLL for synchronization with the input clock to eliminate phase error. This pin should NOT be connected on the circuit board, the feedback is internal to the package.
17	DIF_0	OUT	HCSL true clock output
18	DIF_0#	OUT	HCSL Complementary clock output
19	vOE0#	IN	Active low input for enabling DIF pair 0. This pin has an internal pull-down. 1 =disable outputs, 0 = enable outputs
20	vOE1#	IN	Active low input for enabling DIF pair 1. This pin has an internal pull-down. 1 =disable outputs, 0 = enable outputs
21	DIF_1	OUT	HCSL true clock output
22	DIF_1#	OUT	HCSL Complementary clock output
23	GND	GND	Ground pin.
24	VDD	PWR	Power supply, nominal 3.3V
25	VDDIO	PWR	Power supply for differential outputs
26	DIF_2	OUT	HCSL true clock output
27	DIF_2#	OUT	HCSL Complementary clock output
28	vOE2#	IN	Active low input for enabling DIF pair 2. This pin has an internal pull-down. 1 =disable outputs, 0 = enable outputs
29	vOE3#	IN	Active low input for enabling DIF pair 3. This pin has an internal pull-down. 1 =disable outputs, 0 = enable outputs
30	DIF_3	OUT	HCSL true clock output
31	DIF_3#	OUT	HCSL Complementary clock output
32	VDDIO	PWR	Power supply for differential outputs
33	GND	GND	Ground pin.
34	DIF_4	OUT	HCSL true clock output
35	DIF_4#	OUT	HCSL Complementary clock output
36	vOE4#	IN	Active low input for enabling DIF pair 4. This pin has an internal pull-down. 1 =disable outputs, 0 = enable outputs
37	vOE5#	IN	Active low input for enabling DIF pair 5. This pin has an internal pull-down. 1 =disable outputs, 0 = enable outputs

Pin Descriptions (cont.)

PIN #	PIN NAME	TYPE	DESCRIPTION
38	DIF_5	OUT	HCSL true clock output
39	DIF_5#	OUT	HCSL Complementary clock output
40	VDD	PWR	Power supply, nominal 3.3V
41	GND	GND	Ground pin.
42	DIF_6	OUT	HCSL true clock output
43	DIF_6#	OUT	HCSL Complementary clock output
44	vOE6#	IN	Active low input for enabling DIF pair 6. This pin has an internal pull-down. 1 =disable outputs, 0 = enable outputs
45	vOE7#	IN	Active low input for enabling DIF pair 7. This pin has an internal pull-down. 1 =disable outputs, 0 = enable outputs
46	DIF_7	OUT	HCSL true clock output
47	DIF_7#	OUT	HCSL Complementary clock output
48	GND	GND	Ground pin.
49	VDDIO	PWR	Power supply for differential outputs
50	DIF_8	OUT	HCSL true clock output
51	DIF_8#	OUT	HCSL Complementary clock output
52	vOE8#	IN	Active low input for enabling DIF pair 8. This pin has an internal pull-down. 1 =disable outputs, 0 = enable outputs
53	vOE9#	IN	Active low input for enabling DIF pair 9. This pin has an internal pull-down. 1 =disable outputs, 0 = enable outputs
54	DIF_9	OUT	HCSL true clock output
55	DIF_9#	OUT	HCSL Complementary clock output
56	VDDIO	PWR	Power supply for differential outputs
57	VDD	PWR	Power supply, nominal 3.3V
58	GND	GND	Ground pin.
59	DIF_10	OUT	HCSL true clock output
60	DIF_10#	OUT	HCSL Complementary clock output
61	vOE10#	IN	Active low input for enabling DIF pair 10. This pin has an internal pull-down. 1 =disable outputs, 0 = enable outputs
62	vOE11#	IN	Active low input for enabling DIF pair 11. This pin has an internal pull-down. 1 =disable outputs, 0 = enable outputs
63	DIF_11	OUT	HCSL true clock output
64	DIF_11#	OUT	HCSL Complementary clock output
65	epad	GND	epad, connect to ground

Absolute Maximum Ratings

Stresses above the ratings listed below can cause permanent damage to the 9ZXL1251. These ratings, which are standard values for Renesas commercially rated parts, are stress ratings only. Functional operation of the device at these or any other conditions above those indicated in the operational sections of the specifications is not implied. Exposure to absolute maximum rating conditions for extended periods can affect product reliability. Electrical parameters are guaranteed only over the recommended operating temperature range.

PARAMETER	SYMBOL	CONDITIONS	MIN	TYP	MAX	UNITS	NOTES
Supply Voltage	VDDx				4.6	V	1,2
Input Low Voltage	V _{IL}		GND-0.5			V	1
Input High Voltage	V _{IH}	Except for SMBus interface			V _{DD} +0.5	V	1,3
Input High Voltage	V _{IHSMB}	SMBus clock and data pins			5.5	V	1
Storage Temperature	T _s		-65		150	°C	1
Junction Temperature	T _j				125	°C	1
Input ESD protection	ESD prot	Human Body Model	2000			V	1

¹ Guaranteed by design and characterization, not 100% tested in production.

² Operation under these conditions is neither implied nor guaranteed.

³ Not to exceed 4.6V.

Electrical Characteristics—DIF_IN Clock Input Parameters

T_{AMB} = T_{COM} or T_{IND}, unless noted., Supply Voltages per normal operation conditions, See Test Loads for Loading Conditions

PARAMETER	SYMBOL	CONDITIONS	MIN	TYP	MAX	UNITS	NOTES
Input Crossover Voltage - DIF_IN	V _{CROSS}	Crossover Voltage	150		900	mV	1
Input Swing - DIF_IN	V _{SWING}	Differential value	300			mV	1
Input Slew Rate - DIF_IN	dV/dt	Measured differentially	0.4		8	V/ns	1,2
Input Leakage Current	I _{IN}	V _{IN} = V _{DD} , V _{IN} = GND	-5		5	uA	
Input Duty Cycle	d _{tin}	Measurement from differential waveform	45		55	%	1
Input Jitter - Cycle to Cycle	J _{DIFIN}	Differential Measurement	0		125	ps	1

¹ Guaranteed by design and characterization, not 100% tested in production.

² Slew rate measured through +/-75mV window centered around differential zero.

Electrical Characteristics—SMBus

T_{AMB} = T_{COM} or T_{IND}, unless noted., Supply Voltages per normal operation conditions, See Test Loads for Loading Conditions

PARAMETER	SYMBOL	CONDITIONS	MIN	TYP	MAX	UNITS	NOTES
SMBus Input Low Voltage	V _{ILSMB}				0.8	V	
SMBus Input High Voltage	V _{IHSMB}		2.1		V _{DD} SMB	V	
SMBus Output Low Voltage	V _{OLSMB}	At I _{PULLUP}			0.4	V	
SMBus Sink Current	I _{PULLUP}	At V _{OL}	4			mA	
Nominal Bus Voltage	V _{DD} SMB		2.7		3.6	V	1
SCLK/SDATA Rise Time	t _{RSMB}	(Max V _{IL} - 0.15) to (Min V _{IH} + 0.15)			1000	ns	1
SCLK/SDATA Fall Time	t _{FSMB}	(Min V _{IH} + 0.15) to (Max V _{IL} - 0.15)			300	ns	1
SMBus Operating Frequency	f _{MAXSMB}	Maximum SMBus operating frequency			400	kHz	5

¹ Guaranteed by design and characterization, not 100% tested in production.

² Control input must be monotonic from 20% to 80% of input swing.

³ Time from deassertion until outputs are > 200mV.

⁴ DIF_IN input.

⁵ The differential input clock must be running for the SMBus to be active.

Electrical Characteristics–Input/Supply/Common Parameters

$T_{AMB} = T_{COM}$ or T_{IND} , unless noted., Supply Voltages per normal operation conditions, See Test Loads for Loading Conditions

PARAMETER	SYMBOL	CONDITIONS	MIN	TYP	MAX	UNITS	NOTES
Supply Voltage	VDDx	Supply voltage, except VDDIO	3.135	3.3	3.465	V	
Output Supply Voltage	VDDIO	Supply voltage for DIF outputs, if present	0.95	1.05	3.465	V	
Ambient Operating Temperature	T_{AMB}	Commercial range (T_{COM})	0		70	°C	
		Industrial range (T_{IND})	-40		85	°C	
Input High Voltage	V_{IH}	Single-ended inputs, except SMBus, tri-level inputs	2		$V_{DD} + 0.3$	V	
Input Low Voltage	V_{IL}	Single-ended inputs, except SMBus, tri-level inputs	GND - 0.3		0.8	V	
Input High Voltage	V_{IHTRI}	Tri-Level Inputs	2.2		$V_{DD} + 0.3$	V	
Input Mid Voltage	V_{IMTRI}	Tri-Level Inputs	1.2	VDD/2	1.8	V	
Input Low Voltage	V_{ILTRI}	Tri-Level Inputs	GND - 0.3		0.8	V	
Input Current	I_{IN}	Single-ended inputs, $V_{IN} = GND$, $V_{IN} = V_{DD}$	-5		5	uA	
	I_{INP}	Single-ended inputs $V_{IN} = 0$ V; Inputs with internal pull-up resistors $V_{IN} = V_{DD}$; Inputs with internal pull-down resistors	-200		200	uA	
Input Frequency	F_{ibyp}	$V_{DD} = 3.3$ V, Bypass mode	25		150	MHz	
	F_{ipll}	$V_{DD} = 3.3$ V, 100MHz PLL mode	25	100.00	110	MHz	
	F_{ipll}	$V_{DD} = 3.3$ V, 133.33MHz PLL mode	120	133.33	147	MHz	
Pin Inductance	L_{pin}				7	nH	1
Capacitance	C_{IN}	Logic Inputs, except DIF_IN	1.5		5	pF	1
	C_{INDIF_IN}	DIF_IN differential clock inputs	1.5		2.7	pF	1,4
	C_{OUT}	Output pin capacitance			6	pF	1
Clk Stabilization	T_{STAB}	From V_{DD} Power-Up and after input clock stabilization or de-assertion of PD# to 1st clock		0.18	1.8	ms	1,2
Input SS Modulation Frequency PCIe	$f_{MODINPCIe}$	Allowable Frequency for PCIe Applications (Triangular Modulation)	30		33	kHz	
OE# Latency	$t_{LATOE\#}$	DIF start after OE# assertion DIF stop after OE# deassertion	4		10	clocks	1,2,3
Tdrive_PD#	t_{DRVPD}	DIF output enable after PD# de-assertion			300	us	1,3
Tfall	t_F	Fall time of control inputs			5	ns	2
Trise	t_R	Rise time of control inputs			5	ns	2

¹ Guaranteed by design and characterization, not 100% tested in production.

² Control input must be monotonic from 20% to 80% of input swing.

³ Time from deassertion until outputs are > 200mV.

⁴ DIF_IN input.

Electrical Characteristics–DIF Low Power HCSL Outputs

T_{AMB} = T_{COM} or T_{IND}, unless noted., Supply Voltages per normal operation conditions, See Test Loads for Loading Conditions

PARAMETER	SYMBOL	CONDITIONS	MIN	TYP	MAX	UNITS	NOTES
Slew rate	dV/dt	T _{AMB} = T _{COM} , Scope averaging on	1.6	3.3	4	V/ns	1,2,3
		T _{AMB} = T _{IND} Scope averaging on	1.6	2.8	4.1	V/ns	1,2,3
Slew rate matching	ΔdV/dt	Slew rate matching, Scope averaging on		7	20	%	1,2,4
Voltage High	VHigh	Statistical measurement on single-ended signal using oscilloscope math function. (Scope averaging on)	660	754	850	mV	
Voltage Low	VLow		-150	62	150		
Max Voltage	Vmax	Measurement on single ended signal using absolute value. (Scope averaging off)		868	1150	mV	
Min Voltage	Vmin		-300	-64			
Crossing Voltage (abs)	Vcross_abs	Scope averaging off	250	453	550	mV	1,5
Crossing Voltage (var)	Δ-Vcross	Scope averaging off		17	140	mV	1,6

¹Guaranteed by design and characterization, not 100% tested in production.

² Measured from differential waveform.

³ Slew rate is measured through the Vswing voltage range centered around differential 0V. This results in a +/-150mV window around differential 0V.

⁴ Matching applies to rising edge rate for Clock and falling edge rate for Clock#. It is measured using a +/-75mV window centered on the average cross point where Clock rising meets Clock# falling. The median cross point is used to calculate the voltage thresholds the oscilloscope is to use for the edge rate calculations.

⁵ Vcross is defined as voltage where Clock = Clock# measured on a component test board and only applies to the differential rising edge (i.e. Clock rising and Clock# falling).

⁶ The total variation of all Vcross measurements in any particular system. Note that this is a subset of Vcross_min/max (Vcross absolute) allowed. The intent is to limit Vcross induced modulation by setting Δ-Vcross to be smaller than Vcross absolute.

⁷ At default SMBus settings.

Electrical Characteristics–Current Consumption

T_{AMB} = T_{COM} or T_{IND}, unless noted., Supply Voltages per normal operation conditions, See Test Loads for Loading Conditions

PARAMETER	SYMBOL	CONDITIONS	MIN	TYP	MAX	UNITS	NOTES
Operating Supply Current	I _{DDA}	VDDA, PLL Mode@100MHz		13.4	20	mA	1
		VDDA, PLL Bypass Mode@100MHz		4.8	8	mA	1
	I _{DD}	All other VDD pins		16	25	mA	
	I _{DDIO}	VDDIO for DIF outputs, if applicable		81	95	mA	
Power Down Current	I _{DDA}	VDDA, PLL Mode@100MHz		3	5	mA	1
		VDDA, PLL Bypass Mode@100MHz		3	5	mA	1
	I _{DD}	All other VDD pins		0.14	1	mA	
	I _{DDIO}	VDDIO for DIF outputs, if applicable		0.01	0.3	mA	

¹ Includes VDDR if applicable

Electrical Characteristics—Skew and Differential Jitter Parameters

$T_{AMB} = T_{COM}$ or T_{IND} , unless noted., Supply Voltages per normal operation conditions, See Test Loads for Loading Conditions

PARAMETER	SYMBOL	CONDITIONS	MIN	TYP	MAX	UNITS	NOTES
CLK_IN, DIF[x:0]	t_{SPO_PLL}	Input-to-Output Skew in PLL mode @100MHz, nominal temperature and voltage	-100	3	100	ps	1,2,4,5,8
CLK_IN, DIF[x:0]	t_{PD_BYP}	Input-to-Output Skew in Bypass mode @100MHz, nominal temperature and voltage	2.5	3.6	4.5	ns	1,2,3,5,8
CLK_IN, DIF[x:0]	t_{DSPO_PLL}	Input-to-Output Skew Variation in PLL mode @100MHz, across voltage and temperature	-50	0	50	ps	1,2,3,5,8
CLK_IN, DIF[x:0]	t_{DSPO_BYP}	Input-to-Output Skew Variation in Bypass mode @100MHz, across voltage and temperature, $T_{AMB} = T_{COM}$	-250		250	ps	1,2,3,5,8
		Input-to-Output Skew Variation in Bypass mode @100MHz, across voltage and temperature, $T_{AMB} = T_{IND}$	-350		350	ps	1,2,3,5,8
DIF[x:0]	t_{SKEW_ALL}	Output-to-Output Skew across all outputs @100MHz, $T_{AMB} = T_{COM}$		36	50	ps	1,2,3,8
		Output-to-Output Skew across all outputs @100MHz, $T_{AMB} = T_{IND}$		38	65	ps	1,2,3,8
PLL Jitter Peaking	$j_{peak-hibw}$	LOBW#_BYPASS_HIBW = 1	0	1.2	2.5	dB	7,8
PLL Jitter Peaking	$j_{peak-lobw}$	LOBW#_BYPASS_HIBW = 0	0	0.8	2	dB	7,8
PLL Bandwidth	pll_{HIBW}	LOBW#_BYPASS_HIBW = 1	2	3	4	MHz	8,9
PLL Bandwidth	pll_{LOBW}	LOBW#_BYPASS_HIBW = 0	0.7	1.1	1.4	MHz	8,9
Duty Cycle	t_{DC}	Measured differentially, PLL Mode	45	50	55	%	1
Duty Cycle Distortion	t_{DCD}	Measured differentially, Bypass Mode @100MHz	-1.5	-0.6	0	%	1,10
Jitter, Cycle to cycle	$t_{jyc-cyc}$	PLL mode		25	50	ps	1,11
		Additive Jitter in Bypass Mode		1	5	ps	1,11

Notes for preceding table:

- ¹ Measured into fixed 2pF load cap. Input to output skew is measured at the first output edge following the corresponding input.
- ² Measured from differential cross-point to differential cross-point. This parameter can be tuned with external feedback path, if present.
- ³ All Bypass Mode Input-to-Output specs refer to the timing between an input edge and the specific output edge created by it.
- ⁴ This parameter is deterministic for a given device.
- ⁵ Measured with scope averaging on to find mean value.
- ⁶ t is the period of the input clock.
- ⁷ Measured as maximum pass band gain. At frequencies within the loop BW, highest point of magnification is called PLL jitter peaking.
- ⁸ Guaranteed by design and characterization, not 100% tested in production.
- ⁹ Measured at 3 db down or half power point.
- ¹⁰ Duty cycle distortion is the difference in duty cycle between the output and the input clock when the device is operated in bypass mode.

Electrical Characteristics—Phase Jitter Parameters

T_{AMB} = T_{COM} or T_{IND}, unless noted., Supply Voltages per normal operation conditions, See Test Loads for Loading Conditions

PARAMETER	SYMBOL	CONDITIONS	MIN	TYP	MAX	IND.LIMIT	UNITS	Notes
Phase Jitter, PLL Mode	t _{jphPCIeG1}	PCIe Gen 1		36	49	86	ps (p-p)	1,2,3
	t _{jphPCIeG2}	PCIe Gen 2 Lo Band 10kHz < f < 1.5MHz		1.2	1.6	3	ps (rms)	1,2
		PCIe Gen 2 High Band 1.5MHz < f < Nyquist (50MHz)		2.2	2.8	3.1	ps (rms)	1,2
	t _{jphPCIeG3}	PCIe Gen 3 (PLL BW of 2-4MHz, CDR = 10MHz)		0.56	0.63	1	ps (rms)	1,2,4
	t _{jphQPI_SMI}	QPI & SMI (100MHz or 133MHz, 4.8Gb/s, 6.4Gb/s 12UI)		0.22	0.48	0.5	ps (rms)	1,4
		QPI & SMI (100MHz, 8.0Gb/s, 12UI)		0.15	0.28	0.3	ps (rms)	1,4
		QPI & SMI (100MHz, 9.6Gb/s, 12UI)		0.11	0.17	0.2	ps (rms)	1,4
Additive Phase Jitter, Bypass mode	t _{jphPCIeG1}	PCIe Gen 1		0.0	0.8	n/a	ps (p-p)	1,2,3
	t _{jphPCIeG2}	PCIe Gen 2 Lo Band 10kHz < f < 1.5MHz		0.1	0.2	n/a	ps (rms)	1,2,5
		PCIe Gen 2 High Band 1.5MHz < f < Nyquist (50MHz)		0.4	0.5	n/a	ps (rms)	1,2,5
	t _{jphPCIeG3}	PCIe Gen 3 (PLL BW of 2-4 or 2-5 MHz, CDR = 10MHz)		0.0	0.0	n/a	ps (rms)	1,2,4,5
	t _{jphQPI_SMI}	QPI & SMI (100MHz or 133MHz, 4.8Gb/s, 6.4Gb/s 12UI)		0.11	0.2	n/a	ps (rms)	1,4,5
		QPI & SMI (100MHz, 8.0Gb/s, 12UI)		0.00	0.01	n/a	ps (rms)	1,4,5
		QPI & SMI (100MHz, 9.6Gb/s, 12UI)		0.00	0.01	n/a	ps (rms)	1,4,5

¹ Applies to all outputs.

² See <http://www.pcisig.com> for complete specs.

³ Sample size of at least 100K cycles. This figure extrapolates to 108ps pk-pk at 1M cycles for a BER of 1⁻¹².

⁴ Calculated from Intel-supplied Clock Jitter Tool v1.6.3.

⁵ For RMS figures, additive jitter is calculated by solving the following equation: Additive jitter = SQRT[(total jitter)² - (input jitter)²]

Clock Periods–Differential Outputs with Spread Spectrum Disabled

SSC OFF	Center Freq. MHz	Measurement Window							Units	Notes
		1 Clock	1us	0.1s	0.1s	0.1s	1us	1 Clock		
		-c2c jitter AbsPer Min	-SSC Short-Term Average Min	- ppm Long-Term Average Min	0 ppm Period Nominal	+ ppm Long-Term Average Max	+SSC Short-Term Average Max	+c2c jitter AbsPer Max		
DIF	100.00	9.94900		9.99900	10.00000	10.00100		10.05100	ns	1,2,3
	133.33	7.44925		7.49925	7.50000	7.50075		7.55075	ns	1,2,4

Clock Periods–Differential Outputs with Spread Spectrum Enabled

SSC ON	Center Freq. MHz	Measurement Window							Units	Notes
		1 Clock	1us	0.1s	0.1s	0.1s	1us	1 Clock		
		-c2c jitter AbsPer Min	-SSC Short-Term Average Min	- ppm Long-Term Average Min	0 ppm Period Nominal	+ ppm Long-Term Average Max	+SSC Short-Term Average Max	+c2c jitter AbsPer Max		
DIF	99.75	9.94906	9.99906	10.02406	10.02506	10.02607	10.05107	10.10107	ns	1,2,3
	133.00	7.44930	7.49930	7.51805	7.51880	7.51955	7.53830	7.58830	ns	1,2,4

Notes:

- ¹Guaranteed by design and characterization, not 100% tested in production.
- ²All Long Term Accuracy specifications are guaranteed with the assumption that the input clock complies with CK420BQ/CK410B+ accuracy requirements (+/-100ppm). The 9ZXL1251 itself does not contribute to ppm error.
- ³ Driven by SRC output of main clock, 100 MHz PLL Mode or Bypass mode
- ⁴ Driven by CPU output of main clock, 133 MHz PLL Mode or Bypass mode

Differential Output Terminations

DIF Zo (Ω)	Rs (Ω)
100	NA
85	0

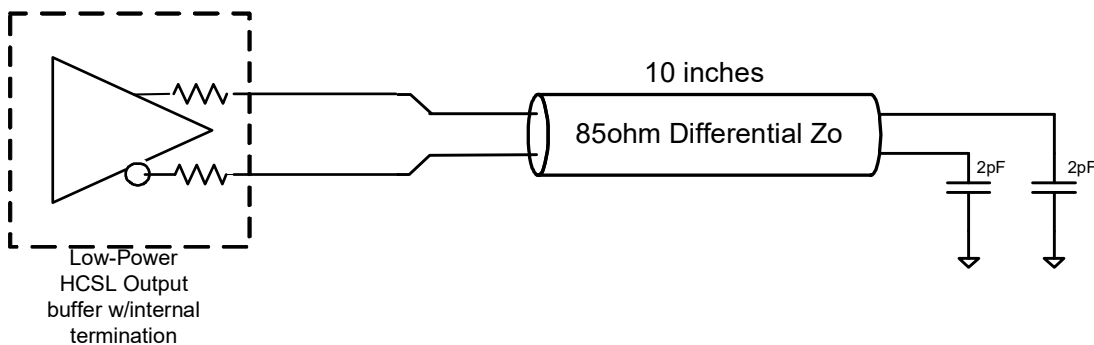

General SMBus Serial Interface Information for 9ZXL1251

How to Write

- Controller (host) sends a start bit
- Controller (host) sends the write address
- Renesas clock will **acknowledge**
- Controller (host) sends the beginning byte location = N
- Renesas clock will **acknowledge**
- Controller (host) sends the byte count = X
- Renesas clock will **acknowledge**
- Controller (host) starts sending Byte **N through Byte N+X-1**
- Renesas clock will **acknowledge** each byte **one at a time**
- Controller (host) sends a Stop bit

How to Read

- Controller (host) will send a start bit
- Controller (host) sends the write address
- Renesas clock will **acknowledge**
- Controller (host) sends the beginning byte location = N
- Renesas clock will **acknowledge**
- Controller (host) will send a separate start bit
- Controller (host) sends the read address
- Renesas clock will **acknowledge**
- Renesas clock will send the data byte count = X
- Renesas clock sends Byte **N+X-1**
- Renesas clock sends **Byte 0 through Byte X (if X_(H) was written to Byte 8)**
- Controller (host) will need to acknowledge each byte
- Controller (host) will send a not acknowledge bit
- Controller (host) will send a stop bit

Index Block Write Operation			
Controller (Host)			Renesas (Slave/Receiver)
T	starT bit		
Slave Address			
WR	WRite		
Beginning Byte = N			ACK
			ACK
Data Byte Count = X			ACK
Beginning Byte N		X Byte	ACK
O			O
O			O
O			O
Byte N + X - 1			ACK
P	stoP bit		

Index Block Read Operation			
Controller (Host)			Renesas
T	starT bit		
Slave Address			
WR	WRite		
Beginning Byte = N			ACK
			ACK
RT	Repeat starT		
Slave Address			
RD	ReaD		ACK
ACK		X Byte	Data Byte Count=X
ACK			Beginning Byte N
O			O
O			O
			O
ACK			
			Byte N + X - 1
N	Not acknowledge		
P	stoP bit		

SMBusTable: PLL Mode, and Frequency Select Register

Byte 0	Pin #	Name	Control Function	Type	0	1	Default
Bit 7	5	PLL Mode 1	PLL Operating Mode Rd back 1	R	See PLL Operating Mode		Latch
Bit 6	5	PLL Mode 0	PLL Operating Mode Rd back 0	R	Readback Table		Latch
Bit 5			Reserved				0
Bit 4			Reserved				0
Bit 3		PLL_SW_EN	Enable S/W control of PLL BW	RW	HW Latch	SMBus Control	0
Bit 2		PLL Mode 1	PLL Operating Mode 1	RW	See PLL Operating Mode		1
Bit 1		PLL Mode 0	PLL Operating Mode 1	RW	Readback Table		1
Bit 0	4	100M_133M#	Frequency Select Readback	R	133MHz	100MHz	Latch

Note: Setting bit 3 to '1' allows the user to override the Latch value from pin 5 via use of bits 2 and 1. Use the values from the PLL Operating Mode Readback Table. Note that Bits 7 and 6 will keep the value originally latched on pin 5. A warm reset of

SMBusTable: Output Control Register

Byte 1	Pin #	Name	Control Function	Type	0	1	Default
Bit 7	47/46	DIF_7_En	Output Control - '0' overrides OE# pin	RW	Low/Low	Enable	1
Bit 6	43/42	DIF_6_En	Output Control - '0' overrides OE# pin	RW			1
Bit 5	39/38	DIF_5_En	Output Control - '0' overrides OE# pin	RW			1
Bit 4	35/34	DIF_4_En	Output Control - '0' overrides OE# pin	RW			1
Bit 3	30/31	DIF_3_En	Output Control - '0' overrides OE# pin	RW			1
Bit 2	26/27	DIF_2_En	Output Control - '0' overrides OE# pin	RW			1
Bit 1	21/22	DIF_1_En	Output Control - '0' overrides OE# pin	RW			1
Bit 0	17/18	DIF_0_En	Output Control - '0' overrides OE# pin	RW			1

SMBusTable: Output Control Register

Byte 2	Pin #	Name	Control Function	Type	0	1	Default
Bit 7			Reserved				0
Bit 6			Reserved				0
Bit 5			Reserved				0
Bit 4			Reserved				0
Bit 3	64/63	DIF_11_En	Output Control - '0' overrides OE# pin	RW	Low/Low	Enable	1
Bit 2	59/60	DIF_10_En	Output Control - '0' overrides OE# pin	RW			1
Bit 1	54/55	DIF_9_En	Output Control - '0' overrides OE# pin	RW			1
Bit 0	50/51	DIF_8_En	Output Control - '0' overrides OE# pin	RW			1

SMBusTable: Reserved Register

Byte 3	Pin #	Name	Control Function	Type	0	1	Default
Bit 7			Reserved				0
Bit 6			Reserved				0
Bit 5			Reserved				0
Bit 4			Reserved				0
Bit 3			Reserved				0
Bit 2			Reserved				0
Bit 1			Reserved				0
Bit 0			Reserved				0

SMBusTable: Reserved Register

Byte 4	Pin #	Name	Control Function	Type	0	1	Default
Bit 7			Reserved				0
Bit 6			Reserved				0
Bit 5			Reserved				0
Bit 4			Reserved				0
Bit 3			Reserved				0
Bit 2			Reserved				0
Bit 1			Reserved				0
Bit 0			Reserved				0

SMBusTable: Vendor & Revision ID Register

Byte 5	Pin #	Name	Control Function	Type	0	1	Default
Bit 7	-	RID3	REVISION ID	R	A rev = 0000		X
Bit 6	-	RID2		R			X
Bit 5	-	RID1		R			X
Bit 4	-	RID0		R			X
Bit 3	-	VID3	VENDOR ID	R	-	-	0
Bit 2	-	VID2		R	-	-	0
Bit 1	-	VID1		R	-	-	0
Bit 0	-	VID0		R	-	-	1

SMBusTable: DEVICE ID

Byte 6	Pin #	Name	Control Function	Type	0	1	Default
Bit 7	-	Device ID 7 (MSB)		R	1251 is 251 Decimal or FB Hex		1
Bit 6	-	Device ID 6		R			1
Bit 5	-	Device ID 5		R			1
Bit 4	-	Device ID 4		R			1
Bit 3	-	Device ID 3		R			1
Bit 2	-	Device ID 2		R			0
Bit 1	-	Device ID 1		R			1
Bit 0	-	Device ID 0		R			1

SMBusTable: Byte Count Register

Byte 7	Pin #	Name	Control Function	Type	0	1	Default
Bit 7			Reserved				0
Bit 6			Reserved				0
Bit 5			Reserved				0
Bit 4	-	BC4	Writing to this register configures how many bytes will be read back.	RW	Default value is 8 hex, so 9 bytes (0 to 8) will be read back by default.		0
Bit 3	-	BC3		RW			1
Bit 2	-	BC2		RW			0
Bit 1	-	BC1		RW			0
Bit 0	-	BC0		RW			0

SMBusTable: Reserved Register

Byte 8	Pin #	Name	Control Function	Type	0	1	Default
Bit 7			Reserved				0
Bit 6			Reserved				0
Bit 5			Reserved				0
Bit 4			Reserved				0
Bit 3			Reserved				0
Bit 2			Reserved				0
Bit 1			Reserved				0
Bit 0			Reserved				0

Marking Diagrams

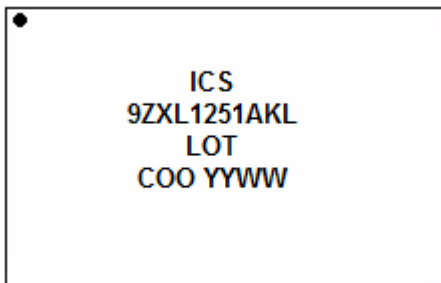

- Line 2: truncated part number
 - “I” denotes industrial temperature grade.
 - “L” denotes RoHS compliant package.
- Line 3: “LOT” denotes the lot number.
- Line 4:
 - “COO” denotes country of origin.
 - “YYWW” is the last two digits of the year and week that the part was assembled.

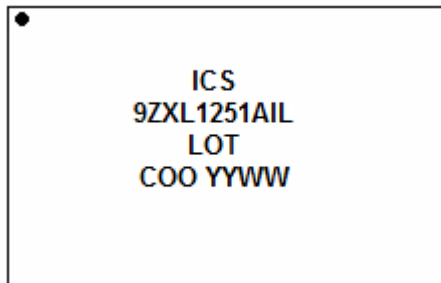

Package Outline Drawings

The [package outline drawings](#) are appended at the end of this document. The package information is the most current data available.

Ordering Information

Part / Order Number	Shipping Package	Package	Temperature
9ZXL1251AKLF	Trays	64-pin VFQFPN	0 to +70°C
9ZXL1251AKLFT	Tape and Reel	64-pin VFQFPN	0 to +70°C
9ZXL1251AKILF	Trays	64-pin VFQFPN	-40 to +85°C
9ZXL1251AKILFT	Tape and Reel	64-pin VFQFPN	-40 to +85°C

“LF” suffix to the part number denotes Pb-Free configuration, RoHS compliant.

“A” is the device revision designator (will not correlate with the datasheet revision).

Revision History

Revision Date	Description
July 23, 2015	Update to final and Release
November 20, 2015	1. Updated QPI references to QPI/UPI 2. Updated DIF_IN table to match PCI SIG specification, no silicon change
January 28, 2021	1. Updated input frequency minimum values from 33MHz to 25MHz. 2. Added "25MHz PFT clock delay management" bullet to Features section on cover page. 3. Reformatted headers and footers to Renesas. 4. Updated Marking Diagram and Package Outline Drawings sections.

PUNCH VERSION DRAWING

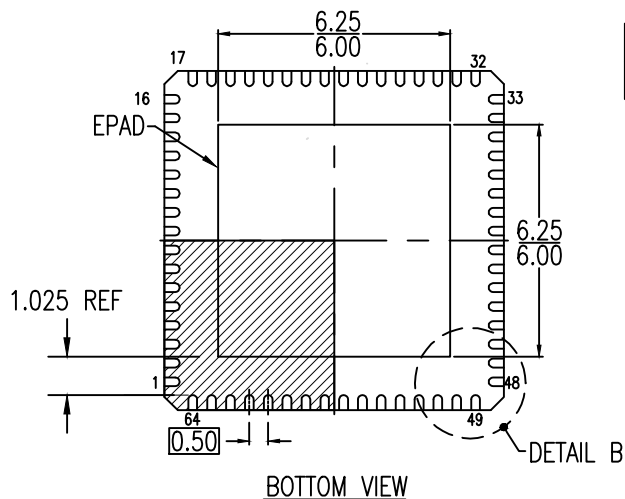
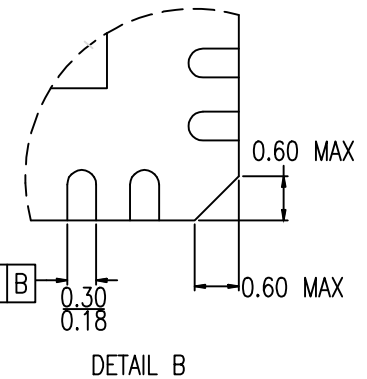
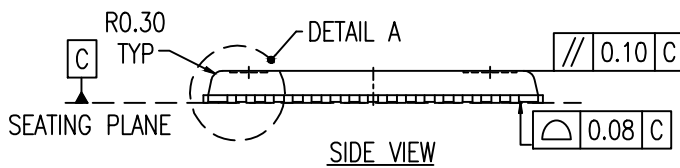
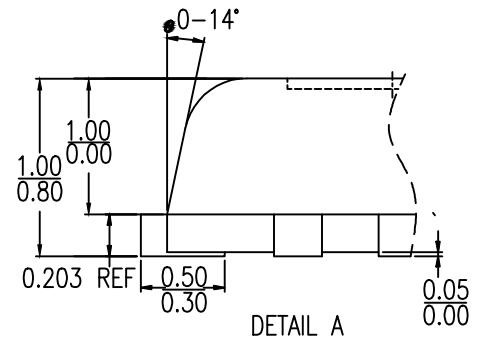
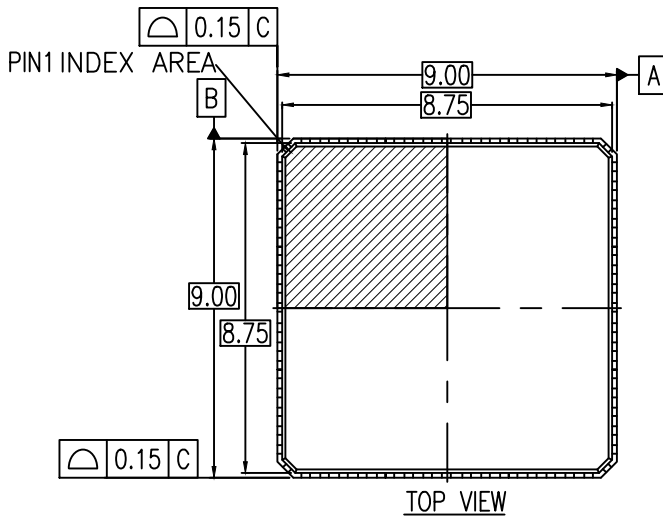

NOTES:

1. REFER TO JEDEC STD: M00-220.
2. DIMENSION "b" APPLIES TO METALLIZED TERMINAL AND IS MEASURED BETWEEN 0.15MM AND 0.30MM FROM THE TERMINAL TIP. THE TERMINAL HAS OPTIONAL RADIUS ON THE OTHER END OF THE TEMRNAL, THE DOMENSION B SHOULD NOT BE MEASURED IN THAT RADIUS AREA.

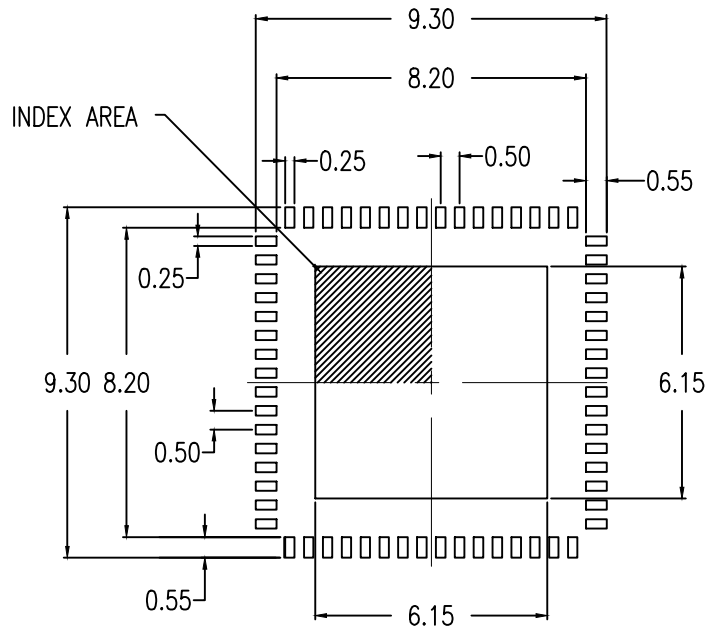

RECOMMENDED LAND PATTERN

NOTES:

1. ALL DIMENSIONS ARE IN MM. ANGLES IN DEGREES.
2. TOP DOWN VIEW AS VIEWED ON PCB.
3. LAND PATTERN IN BLUE. NSMD PATTERN ASSUMED.
4. LAND PATTERN RECOMMENDATION PER IPC-7351 LP CALCULATOR.

Package Revision History		
Date Created	Rev No.	Description
Feb 20, 2018	Rev 01	Change QFN to VFQFPN, Added D2
Nov 3, 2015	Rev 00	Initial Release

IMPORTANT NOTICE AND DISCLAIMER

RENESAS ELECTRONICS CORPORATION AND ITS SUBSIDIARIES (“RENESAS”) PROVIDES TECHNICAL SPECIFICATIONS AND RELIABILITY DATA (INCLUDING DATASHEETS), DESIGN RESOURCES (INCLUDING REFERENCE DESIGNS), APPLICATION OR OTHER DESIGN ADVICE, WEB TOOLS, SAFETY INFORMATION, AND OTHER RESOURCES “AS IS” AND WITH ALL FAULTS, AND DISCLAIMS ALL WARRANTIES, EXPRESS OR IMPLIED, INCLUDING, WITHOUT LIMITATION, ANY IMPLIED WARRANTIES OF MERCHANTABILITY, FITNESS FOR A PARTICULAR PURPOSE, OR NON-INFRINGEMENT OF THIRD PARTY INTELLECTUAL PROPERTY RIGHTS.

These resources are intended for developers skilled in the art designing with Renesas products. You are solely responsible for (1) selecting the appropriate products for your application, (2) designing, validating, and testing your application, and (3) ensuring your application meets applicable standards, and any other safety, security, or other requirements. These resources are subject to change without notice. Renesas grants you permission to use these resources only for development of an application that uses Renesas products. Other reproduction or use of these resources is strictly prohibited. No license is granted to any other Renesas intellectual property or to any third party intellectual property. Renesas disclaims responsibility for, and you will fully indemnify Renesas and its representatives against, any claims, damages, costs, losses, or liabilities arising out of your use of these resources. Renesas' products are provided only subject to Renesas' Terms and Conditions of Sale or other applicable terms agreed to in writing. No use of any Renesas resources expands or otherwise alters any applicable warranties or warranty disclaimers for these products.

(Disclaimer Rev.1.0 Mar 2020)

Corporate Headquarters

TOYOSU FORESIA, 3-2-24 Toyosu,
Koto-ku, Tokyo 135-0061, Japan
www.renesas.com

Contact Information

For further information on a product, technology, the most up-to-date version of a document, or your nearest sales office, please visit:
www.renesas.com/contact/

Trademarks

Renesas and the Renesas logo are trademarks of Renesas Electronics Corporation. All trademarks and registered trademarks are the property of their respective owners.