

PART NAME

TRANSPARENT BLUE NEMA ENCLOSURE

PART No.

BT-2742

UL FILE #194432

MATERIAL:

POLYCARBONATE, TRANSPARENT BLUE

UL94V-2 FLAMMABILITY RATING

UV STABILIZED

SERVICE TEMPERATURE RANGE: -40°C TO +120°C

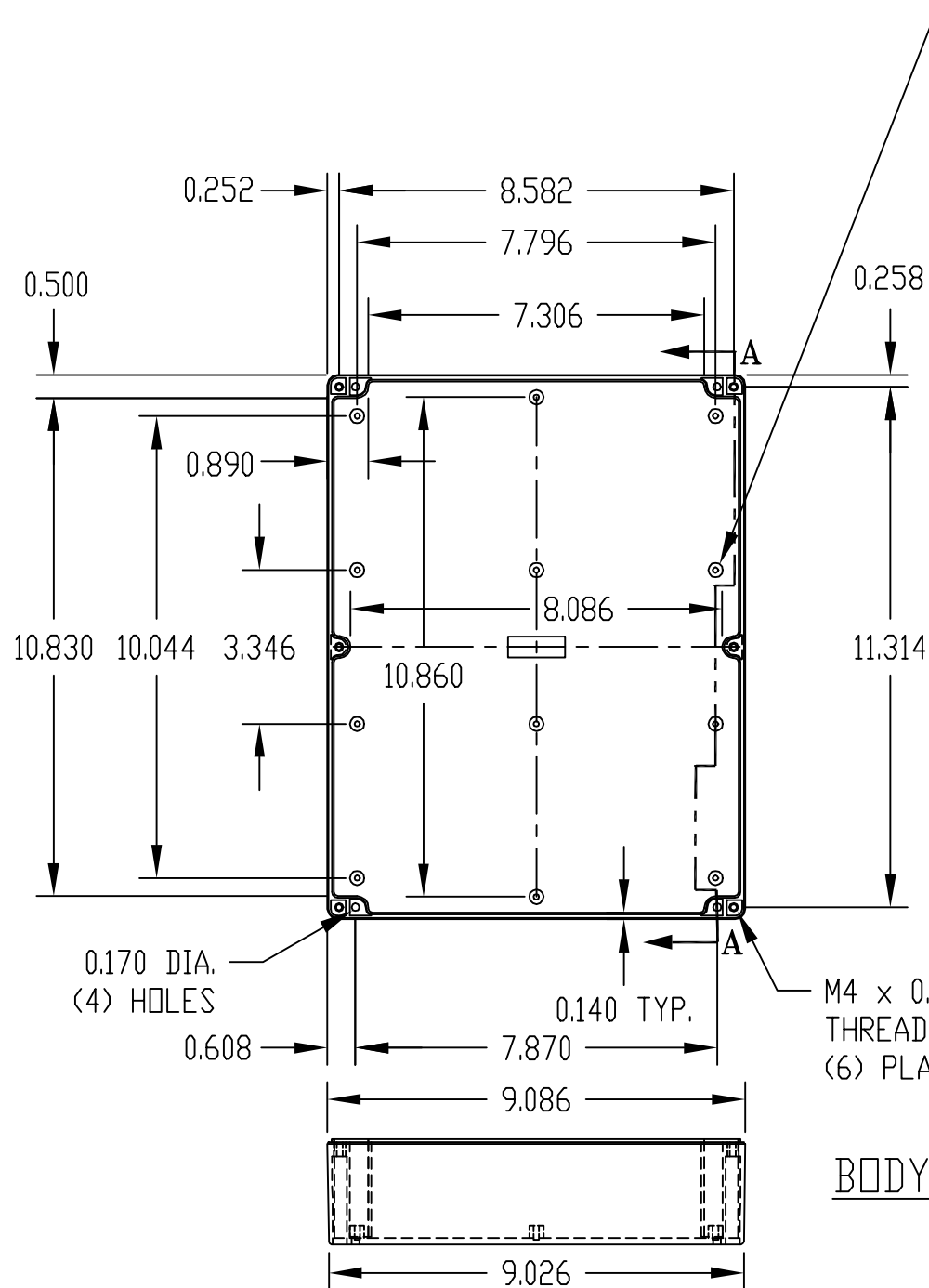

0.315 DIA. BOSS WITH
0.120 DIA. HOLE x 0.320 DEEP
(12) PLACES
MOUNTING BOSSES USE EITHER
M3 METRIC OR #6 STD. SHEET
METAL SCREWS x 0.312 LG.
(NOT SUPPLIED)

M4 x 0.315 LG.
THREADED INSERT
(6) PLACES

BODY

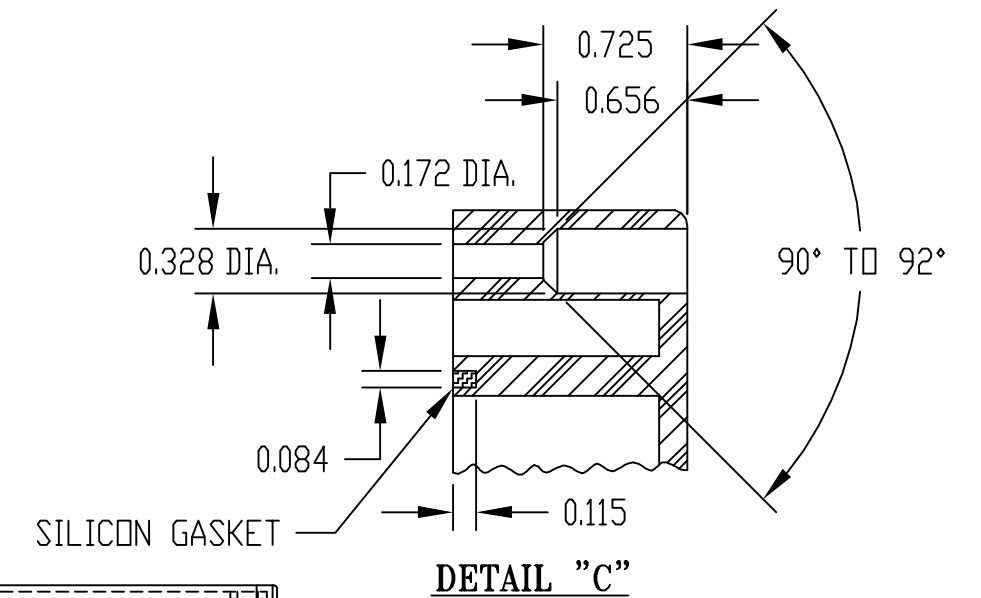

DETAIL "C"

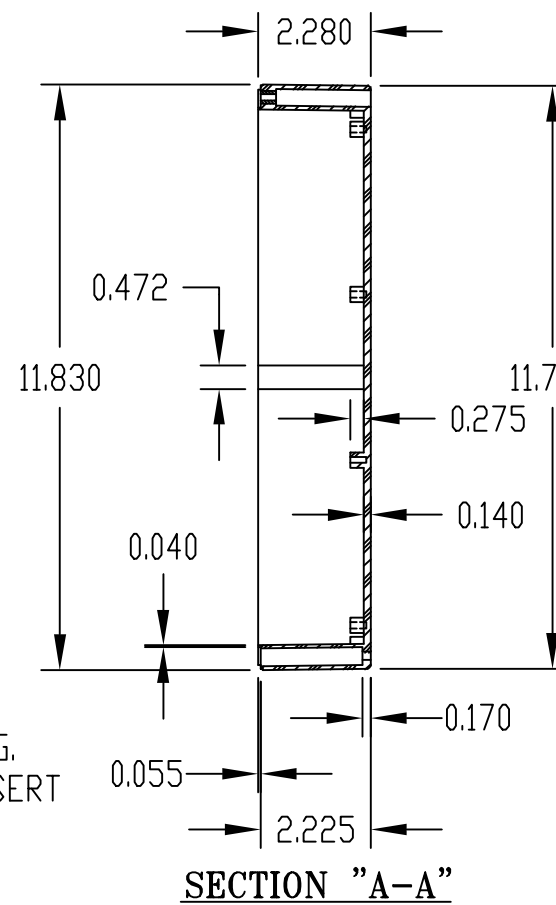

SECTION "A-A"

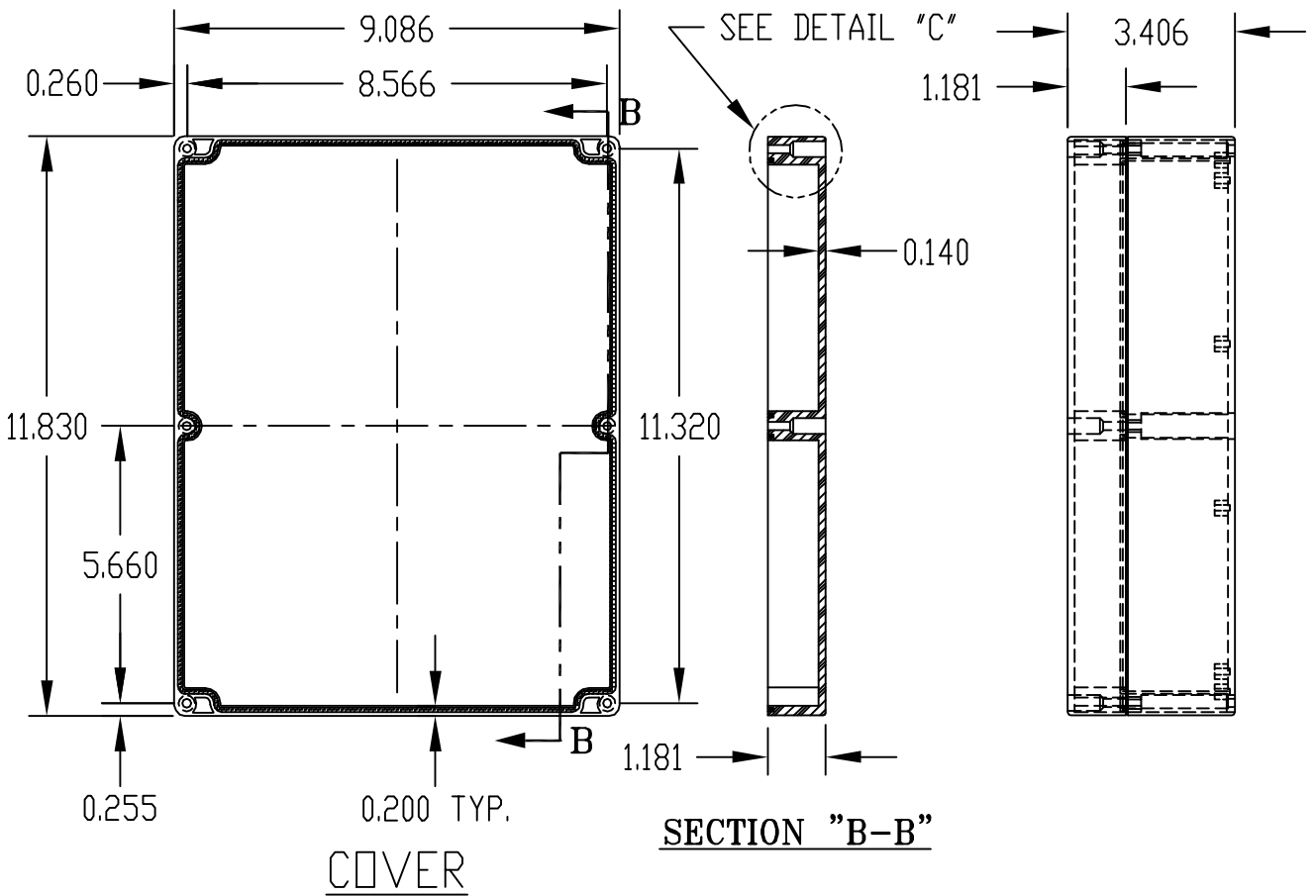

COVER

SECTION "B-B"

NOTE: ALL DIMENSIONS HAVE ±0.015 TOLERANCE UNLESS OTHERWISE SPECIFIED.

HARDWARE KIT

KIT CONTAINS (6)
M4 x 25mm (1.000") LG.
SCREWS FOR ASSEMBLY