

REVISIONS				
REV	DATE	DESCRIPTION	BY	APP'D
B6	10OCT2017	REVISED PER ECO-17-002273	RK	AS

Specifications:

Materials:
CASE: NYLON 66 UL94HB, 30% GF-BLACK
ACTUATOR: PBT OR NYLON 66, UL94HB
COVER: STEEL-TIN PLATE
MOVING CONTACT: COPPER ALLOY-SILVER PLATE
FIXED CONTACT/TERMINAL: COPPER ALLOY-SILVER OVER NICKEL PLATE

Electrical:
Max Contact Rating: 50 milliamp@ 24V DC
Min Contact Rating: 10 microamp@1V DC
Initial Contact resistance, 100 milliohms max
Insulation Resistance, 100 Megohm min. @ 100V DC
Dielectric strength, 500 V AC for 1 minute
Life Expectancy, 100,000 cycles min (2 cycles per second and 150% actuation force)

Mechanical:
Actuation force, See Table
Actuation Travel, .010 +.008/-.004
Life Expectancy, 100,000 cycles min (2 cycles per second and 150% actuation force)

Environmental:
Operating Temperature, -35 to +85 degrees C
Storage Temperature, -35 to +85 degrees C
Thermal Shock, Per EIA-364-32C, -35 to +85 degrees C
Solderability, Per EIA-364-52, Class 2, Category 1, Category 2, 95% Minimum coverage
Resistance to Solder Heat, Per 109-202, Condition B

Notes:

- ALL MATERIALS AND FINISHES SHALL COMPLY WITH EU DIRECTIVE 2002/95/EC OF 27JAN2003 (ROHS).
- PACKAGED IN TRAY

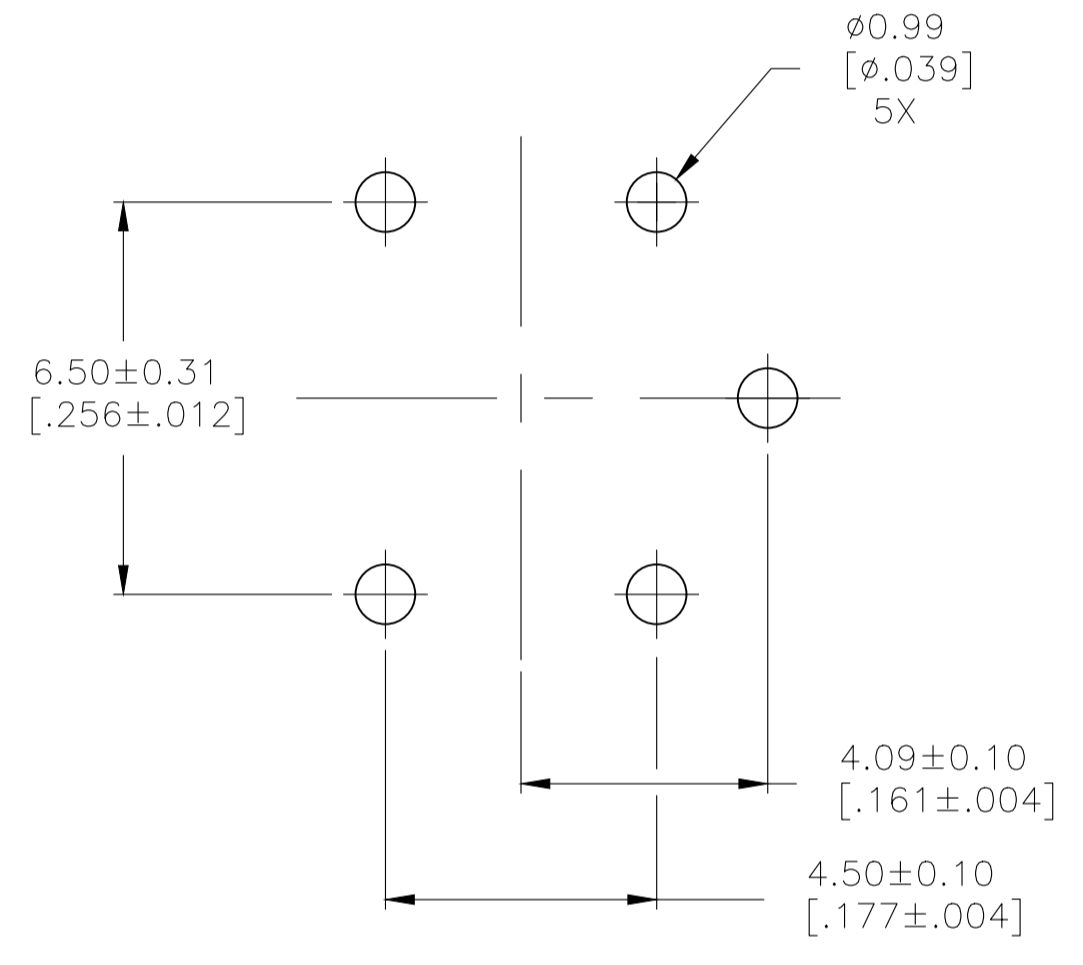
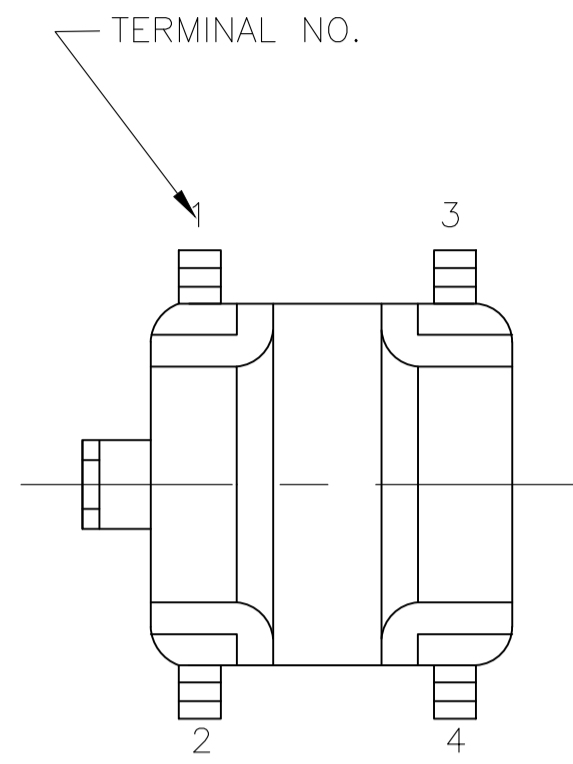
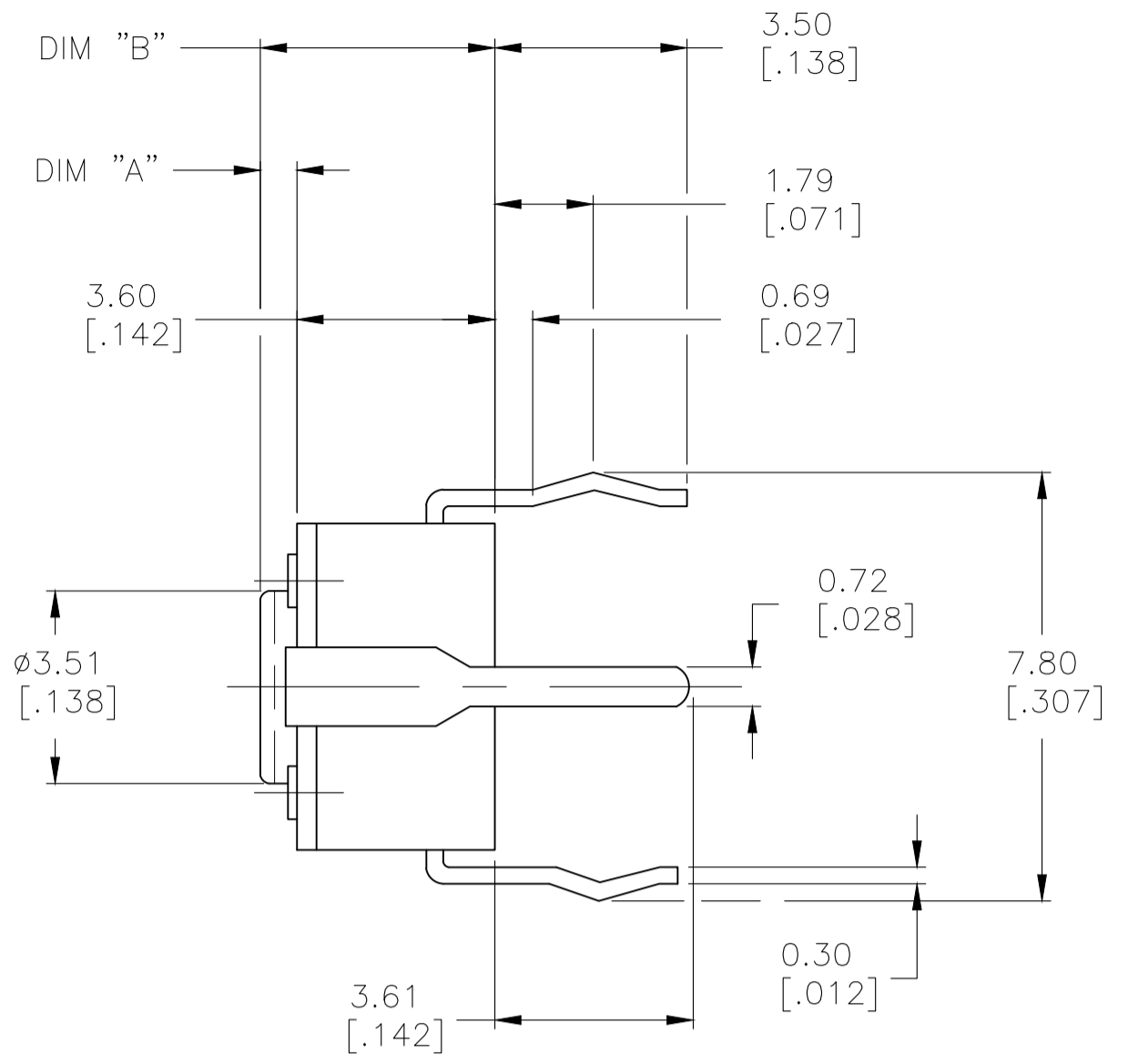
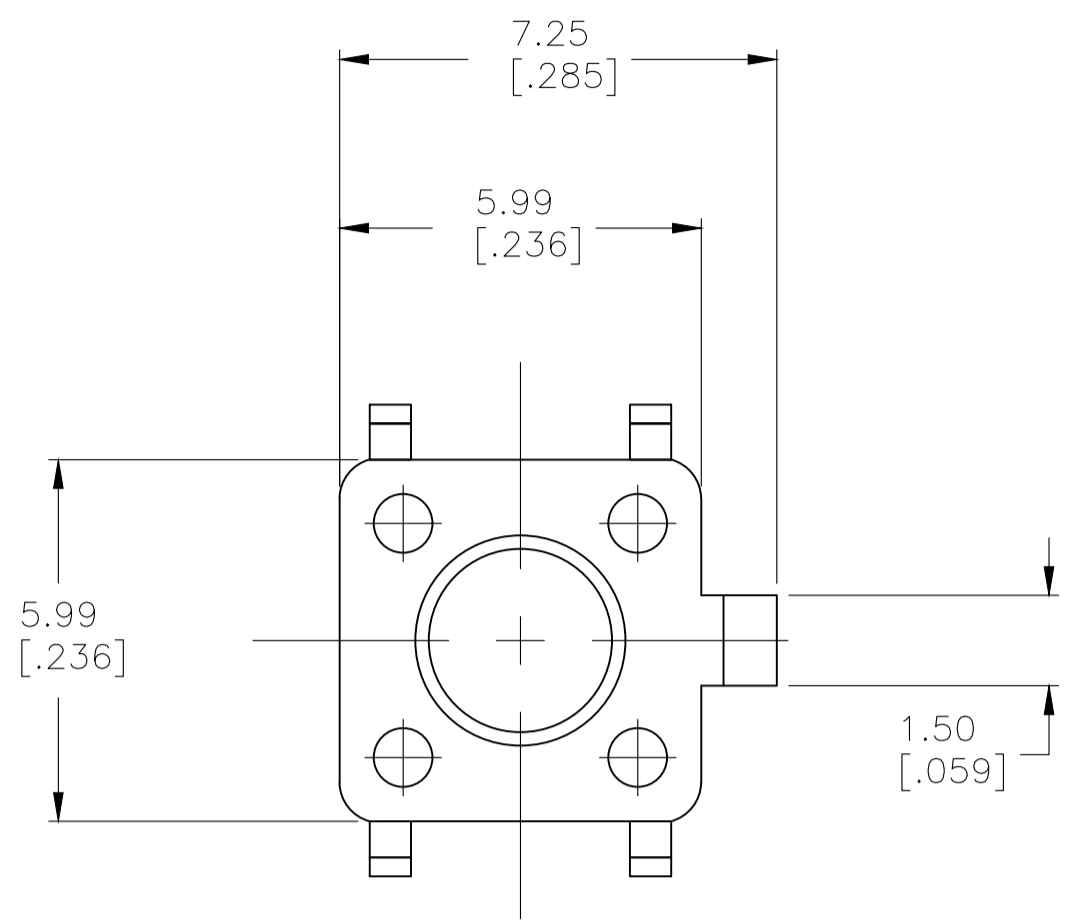

RECOMMENDED HOLE LAYOUT
TOLERANCE ±.002
UNLESS OTHERWISE NOTED

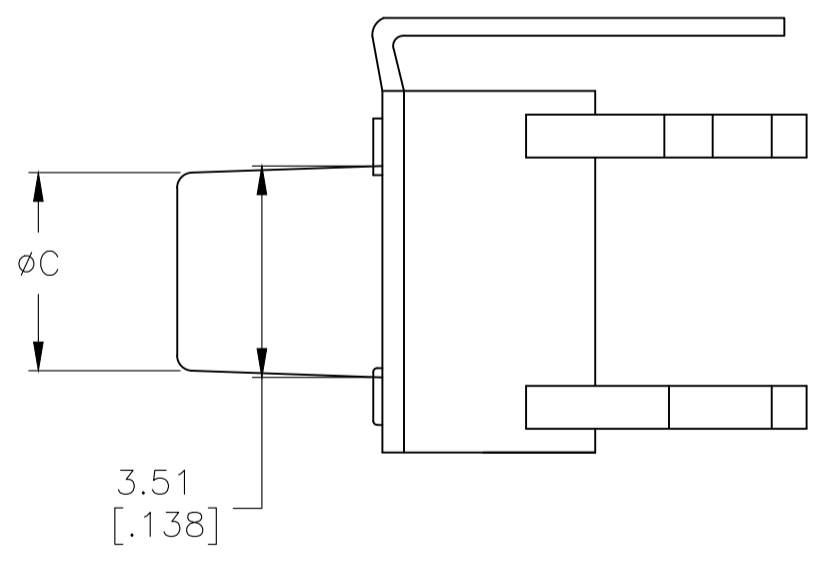
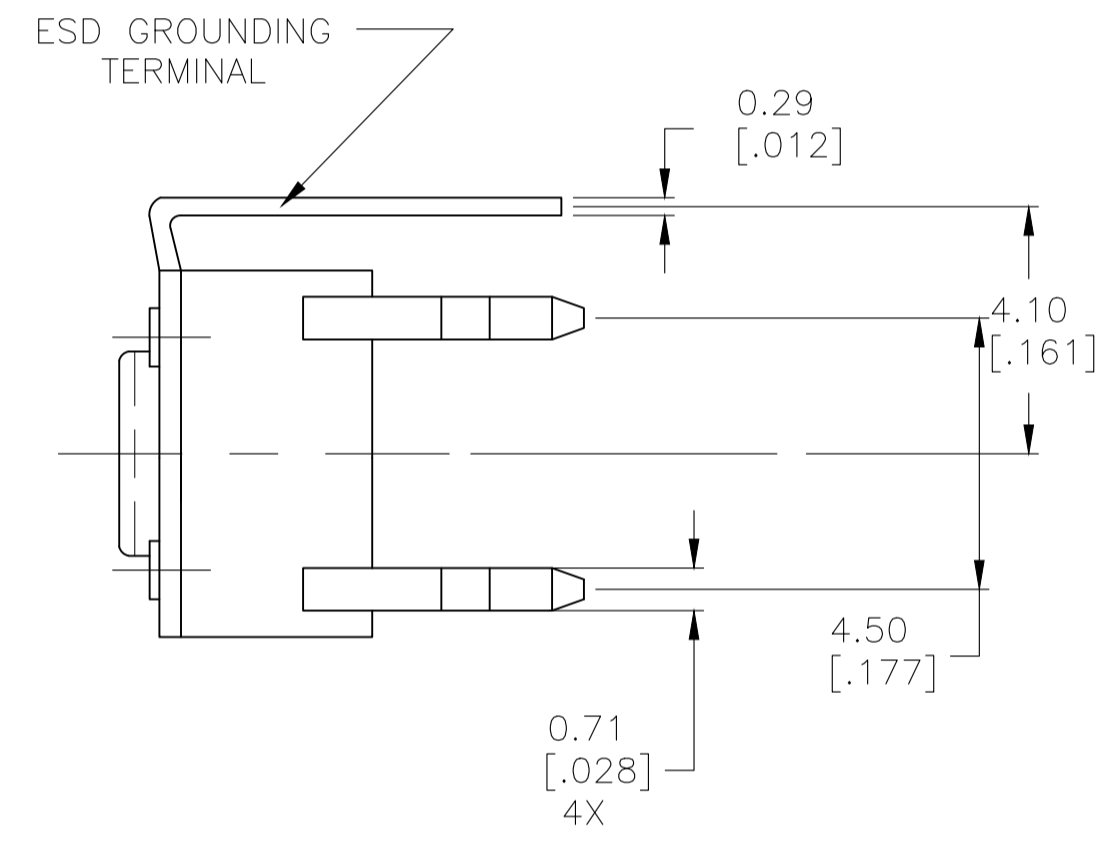

FSM5J THRU FSM17J

CONTACT POSITION		CIRCUIT DIAGRAM
OFF	(ON) 1-3 2-4	

REV	ACTUATOR MAT'L	ACTUATOR COLOR	ACTUATION FORCE	DIM C	DIM B	DIM A	MALCO P/N	P/N
2	PBT	BLACK	160 +/-50 GF	N/A	5.00 (.196)	1.40 (.055)	FSM3JHTR	3-1825955-7
	NYLON 6/6	YELLOW	520 +/-100 GF	3.09 (.122)	8.50 (.335)	4.90 (.193)	FSM17JAAH	3-1825955-6
	NYLON 6/6	WHITE	260 +/-50 GF	3.09 (.122)	8.50 (.335)	4.90 (.193)	FSM17JAH	3-1825955-5
	NYLON 6/6	BLACK	160 +/-50 GF	3.09 (.122)	8.50 (.335)	4.90 (.193)	FSM17JH	3-1825955-4
	NYLON 6/6	BROWN	100 +/-50 GF	3.09 (.122)	8.50 (.335)	4.90 (.193)	FSM17JLH	3-1825955-3
	NYLON 6/6	YELLOW	520 +/-100 GF	2.80 (.110)	17.00 (.669)	13.40 (.527)	FSM15JAAH	3-1825955-2
	NYLON 6/6	WHITE	260 +/-50 GF	2.80 (.110)	17.00 (.669)	13.40 (.527)	FSM15JAH	3-1825955-1
	NYLON 6/6	BLACK	160 +/-50 GF	2.80 (.110)	17.00 (.669)	13.40 (.527)	FSM15JH	3-1825955-0
	NYLON 6/6	BROWN	100 +/-50 GF	2.80 (.110)	17.00 (.669)	13.40 (.527)	FSM15JLH	2-1825955-9
	NYLON 6/6	YELLOW	520 +/-100 GF	2.87 (.118)	13.00 (.512)	9.40 (.370)	FSM13JAAH	2-1825955-8
	NYLON 6/6	WHITE	260 +/-50 GF	2.87 (.118)	13.00 (.512)	9.40 (.370)	FSM13JAH	2-1825955-7
	NYLON 6/6	BLACK	160 +/-50 GF	2.87 (.118)	13.00 (.512)	9.40 (.370)	FSM13JH	2-1825955-6
	NYLON 6/6	BROWN	100 +/-50 GF	2.87 (.118)	13.00 (.512)	9.40 (.370)	FSM13JLH	2-1825955-5
	NYLON 6/6	YELLOW	520 +/-100 GF	3.20 (.126)	8.00 (.315)	4.40 (.173)	FSM11JAAH	2-1825955-4
	NYLON 6/6	WHITE	260 +/-50 GF	3.20 (.126)	8.00 (.315)	4.40 (.173)	FSM11JAH	2-1825955-3
	NYLON 6/6	BLACK	160 +/-50 GF	3.20 (.126)	8.00 (.315)	4.40 (.173)	FSM11JH	2-1825955-2
	NYLON 6/6	BROWN	100 +/-50 GF	3.20 (.126)	8.00 (.315)	4.40 (.173)	FSM11JLH	2-1825955-1
	NYLON 6/6	YELLOW	520 +/-100 GF	3.25 (.128)	7.30 (.287)	3.70 (.146)	FSM9JAAH	2-1825955-0
	NYLON 6/6	WHITE	260 +/-50 GF	3.25 (.128)	7.30 (.287)	3.70 (.146)	FSM9JAH	1-1825955-9
	NYLON 6/6	BLACK	160 +/-50 GF	3.25 (.128)	7.30 (.287)	3.70 (.146)	FSM9JH	1-1825955-8
	NYLON 6/6	BROWN	100 +/-50 GF	3.25 (.128)	7.30 (.287)	3.70 (.146)	FSM9JLH	1-1825955-7
	PBT	YELLOW	520 +/-100 GF	3.10 (.122)	9.50 (.374)	5.90 (.232)	FSM7JAAH	1-1825955-6
	PBT	WHITE	260 +/-50 GF	3.10 (.122)	9.50 (.374)	5.90 (.232)	FSM7JAH	1-1825955-5
	PBT	BLACK	160 +/-50 GF	3.10 (.122)	9.50 (.374)	5.90 (.232)	FSM7JH	1-1825955-4
	PBT	BROWN	100 +/-50 GF	3.10 (.122)	9.50 (.374)	5.90 (.232)	FSM7JLH	1-1825955-3
	NYLON 6/6	YELLOW	520 +/-100 GF	3.30 (.130)	7.00 (.276)	3.40 (.134)	FSM5JAAH	1-1825955-2
	NYLON 6/6	WHITE	260 +/-50 GF	3.30 (.130)	7.00 (.276)	3.40 (.134)	FSM5JAH	1-1825955-1
	NYLON 6/6	BLUE	160 +/-50 GF	3.30 (.130)	7.00 (.276)	3.40 (.134)	FSM5JH	1-1825955-0
	NYLON 6/6	BROWN	100 +/-50 GF	3.30 (.130)	7.00 (.276)	3.40 (.134)	FSM5JLH	1825955-9
	PBT	YELLOW	520 +/-100 GF	N/A	5.00 (.196)	1.40 (.055)	FSM3JAAH	1825955-8
	PBT	WHITE	260 +/-50 GF	N/A	5.00 (.196)	1.40 (.055)	FSM3JAH	1825955-7
	PBT	BLACK	160 +/-50 GF	N/A	5.00 (.196)	1.40 (.055)	FSM3JH	1825955-6
	PBT	BROWN	100 +/-50 GF	N/A	5.00 (.196)	1.40 (.055)	FSM3JLH	1825955-5
	PBT	YELLOW	520 +/-100 GF	N/A	4.30 (.169)	0.70 (.028)	FSM1JAAH	1825955-4
	PBT	WHITE	260 +/-50 GF	N/A	4.30 (.169)	0.70 (.028)	FSM1JAH	1825955-3
	PBT	BLACK	160 +/-50 GF	N/A	4.30 (.169)	0.70 (.028)	FSM1JH	1825955-2
	PBT	BROWN	100 +/-50 GF	N/A	4.30 (.169)	0.70 (.028)	FSM1JLH	1825955-1

THIS DRAWING IS A CONTROLLED DOCUMENT. DIM C MORAN 29DEC93

DIMENSIONS: mm [INCHES] TOLERANCES UNLESS OTHERWISE SPECIFIED:

0 PLC	±
1 PLC	±
2 PLC	± 0.31[0.012]
3 PLC	±
4 PLC	±
ANGLES	± 1°

MATERIAL SEE SPECIFICATIONS FINISH SEE SPECIFICATIONS WEIGHT --

CUSTOMER DRAWING

APPROVED: J. SYLVIA 29DEC93 NAME: 6MM TACT SWITCH THRU-HOLE W/ESD

SIZE: A1 CAGE CODE: 00779 DRAWING NO: 1825955

SCALE: 8:1 SHEET: 1 OF 1 REV: B6

STE TE Connectivity