

T H E R M O M E T R I C S  
A C O M M I T M E N T T O E X C E L L E N C E

# Inline Flow-Through Fluid Temperature Sensor

Thermometrics Inline Flow-Through Fluid Temperature Sensor provides inline fluid temperature measurement in heat exchange systems. Its design allows for convenient placement of the sensor at inlet/outlet locations for temperature control, or cooling/heating efficiency measurements, in devices, such as heat exchangers, radiators, and Electric Vehicle (EV) battery packs.



The Inline Flow-Through Fluid Temperature Sensor is based on NTC thermistor technology. When applied to a voltage divider system, a voltage signal that is proportional to the change in fluid temperature is obtained. The voltage divider system is generally contained in the OEM/Tier 1 control module.

## Applications

- Engine Coolant Temperature
- Battery Pack Coolant Line Temperature
- Process Flow Management
- HVAC Water Management
- Home Appliances

## Features

- High sensitivity
- Wide application range
- Compact design
- Interface Options:
  - SAE J-1231 - For elastomeric hoses
  - Triple Barb - For rigid polymer hose
- USCAR sealed connection system
- Available in four standard hose sizes



**Amphenol**  
Advanced Sensors

# Specifications

## Operating Temperature

-40°C to 120°C (-40°F to 248°F)

## Storage Temperature

-40°C to 120°C (-40°F to 248°F)

## R @ 77°F (25°C)

10 KΩ ± 1.5%

## Beta

Part Number	Beta (25/85)°C
GE-2102	3977K
GE-1935	3977K
GE-2103	3977K
CTTS-302651-F01	3435K

## Housing Material

Polyamide 6/6

Color: Black

## Mating Connector

Molex 31403-2100 without CPA Lock

Molex 31403-2110 with CPA Lock

## Thermistor Material System

Part Number	Material
GE-2102	Material 1
GE-1935	Material 1
GE-2103	Material 1
CTTS-302651-F01	Material 4A

## Mechanical

Part Number	Hose Size	SAE J1231 Hose Dash Size	Weight
GE-2102	0.50 in (12.70 mm)	-8	~8g
GE-1935	0.75 in (19.05 mm)	-12	~14g
GE-2103	1.25 in (31.75 mm)	-20	~26g
CTTS-302651-F01 <sup>(1)</sup>	0.63 in (16 mm)	N/A	~10.1g

1. CTTS-302651-F01 requires the use of two customer-supplied Ø14mm ID x Ø2.0mm CS O-rings. Material of O-rings will be dependent upon chemical compatibility of system fluid.

## Typical Application



## GE Series RvT Table

Temp. (°C)	Resistance (Ω)	Resistance Tolerance (± %)	Temp. Tolerance (±°C)
-40	332776	5.95	0.90
-20	96481	4.24	0.73
0	32566	2.71	0.53
20	12486	1.72	0.38
25	10000	1.50	0.34
40	5331	0.34	0.52
60	2490	2.84	0.79
85	1071	3.58	0.79
100	678.1	4.19	1.43
120	387.3	4.59	1.72

## CTTS RvT Table

Temp. (°C)	Resistance (Ω)	Resistance Tolerance (± %)	Temp. Tolerance (±°C)
-40	209587	4.6	0.8
-20	71203	3.5	0.7
0	27758	2.5	0.6
20	12116	1.7	0.4
25	10000	1.5	0.4
40	5807	2.1	0.6
60	3009	2.7	0.9
85	1450	3.5	1.3
100	968.4	3.9	1.5
120	579.8	4.4	1.8

## Typical Circuit Diagram

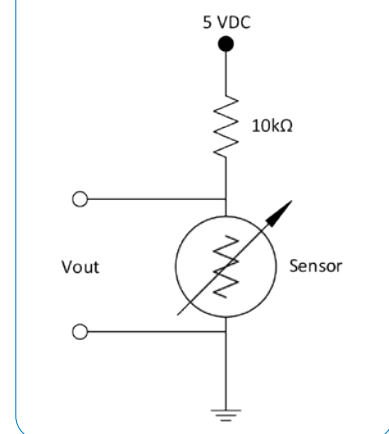

# Dimensions mm [in]

**CTTS-302651-F01**  
**TRIPLE BARB**  
**16mm HOSE**

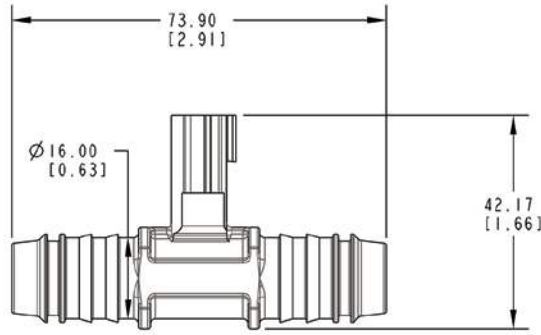

**GE-2102**  
**-8, 1/2" HOSE**

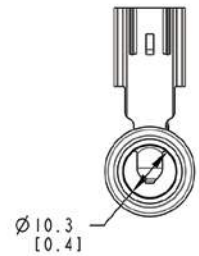
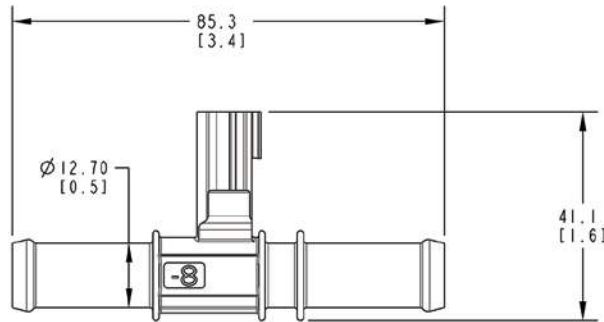

**GE-1935**  
**-12, 3/4" HOSE**

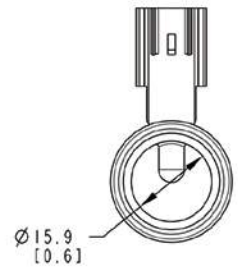
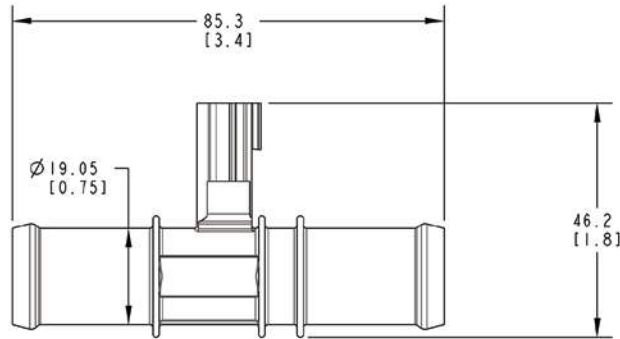

**GE-2103**  
**-20, 1 1/4" HOSE**

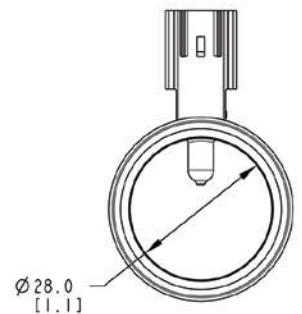
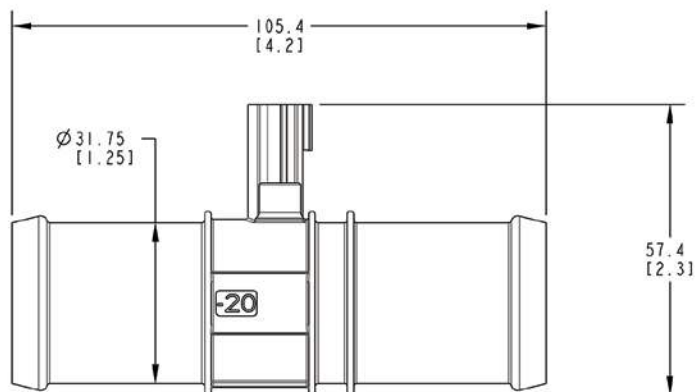

**Amphenol**  
**Advanced Sensors**

[www.amphenol-sensors.com](http://www.amphenol-sensors.com)

© 2021 Amphenol Corporation. All Rights Reserved. Specifications are subject to change without notice.

AAS-920-657G - 06/2021