

FCI PART NO.	LENGTH
10129386-P0031YYLF	310±2
10129386-P0038YYLF	380±2

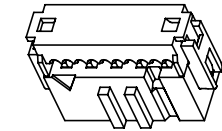

WIRING LIST	
CN1	CN2
1	1
2	2
3	3
⋮	⋮
8	8
9	9
10	10

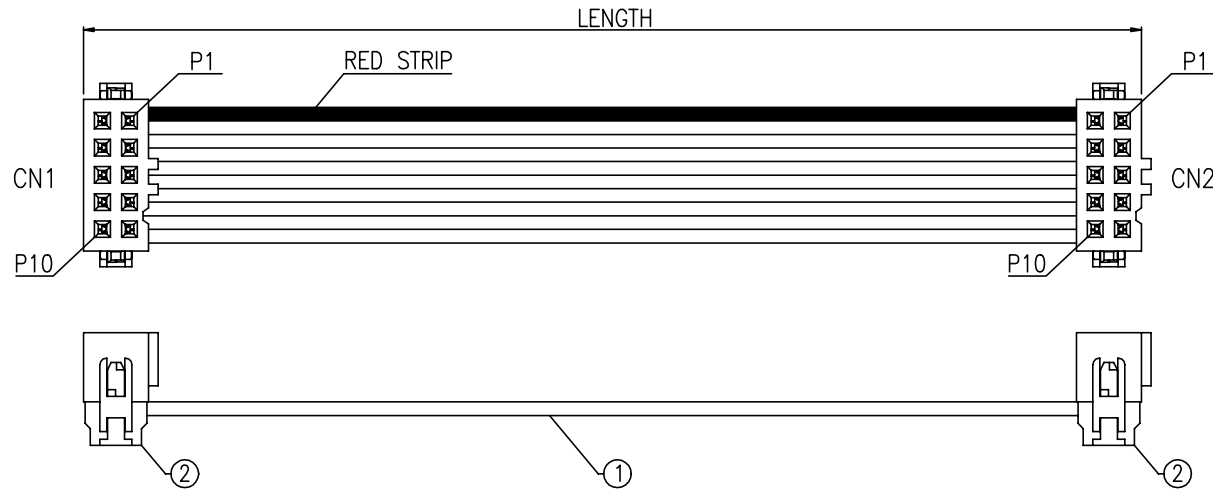

NOTES:

1. MATERIAL: SEE BOM ON SHEET 1.
2. THIS DIMENSION IS A FINISHED PRODUCT LENGTH.
3. ALL CABLE ASSEMBLIES SHALL BE TESTED 100% FOR CONTINUITY AS DEFINED IN WIRING LIST.
4. UNLESS OTHERWISE SPECIFIED ALL CABLE ASSEMBLIES SHALL BE TESTED:
 HI-POT: DC 300V/10ms
 DIELECTRIC RESISTANCE: 10M Ohms MIN.
 CONNECTION RESISTANCE: 3 Ohms MAX.
5. LEAD FREE PRODUCTS MEET EUROPEAN UNION DIRECTIVES AND OTHER COUNTRY REGULATIONS AS DESCRIBED IN GS-22-008.

2	EA	IDC CONN: 2.54PITCH 2*5PIN, 0.76um Au, WITH CENTRAL KEY AND WITHOUT STRAIN RELIEF, FCI P/N:71600-110LF	2
A/R	M	FLAT CABLE: 1.27PITCH 28AWG*10C, UL2651, COLOR:GRAY	1
Q'TY	UNIT	DESCRIPTION	ITEM

spec ref	See Notes			dr	Carl Wang	2014-12-30	projection	MM	size	A3	scale	N/A	
tolerance std	TOLERANCES UNLESS OTHERWISE SPECIFIED			eng	Carl Wang	2014-12-30			ecn no		rev A		
surface	linear	0.X	±		title QUICKIE IDC CABLE ASSEMBLY	www.fci.com			cat. no.	product family		rel level	
		0.XX	±									dwg no 10129386	sheet 1 of 1
	angular	0°	±°	Product - Customer Drw									

