



FAST CMOS 16-BIT BUFFER/LINE DRIVER

IDT54/74FCT162244T/AT/CT/ET

FEATURES:

- 0.5 MICRON CMOS Technology
- High-speed, low-power CMOS replacement for ABT functions
- Typical $t_{sk(o)}$ (Output Skew) < 250ps
- Low input and output leakage $\leq 1\mu A$ (max.)
- ESD > 2000V per MIL-STD-883, Method 3015; > 200V using machine model (C = 200pF, R = 0)
- **Balanced Output Drivers:**
 - $\pm 24mA$ (industrial)
 - $\pm 16mA$ (military)
- Reduced system switching noise
- Typical $VoLP$ (Output Ground Bounce) < 0.6V at $V_{cc} = 5V$, $T_A = 25^\circ C$
- Available in the following packages:
 - Industrial: SSOP, TSSOP
 - Military: CERPACK

DESCRIPTION:

The FCT162244T 16-Bit Buffer/Line Driver is for bus interface or signal buffering applications requiring high speed and low power dissipation. These devices have a flow through pin organization, and shrink packaging to simplify board layout. All inputs are designed with hysteresis for improved noise margin. The three-state controls allow independent 4-bit, 8-bit or combined 16-bit operation. These parts are plug in replacements for 54/74ABT16244 where higher speed, lower noise or lower power dissipation levels are desired.

The FCT162244T has balanced output current levels and current limiting resistors. These offer low ground bounce, minimal undershoot, and controlled output fall times, reducing the need for external series terminating resistors while still providing very high speed operation for loads of less than 200pF.

FUNCTIONAL BLOCK DIAGRAM

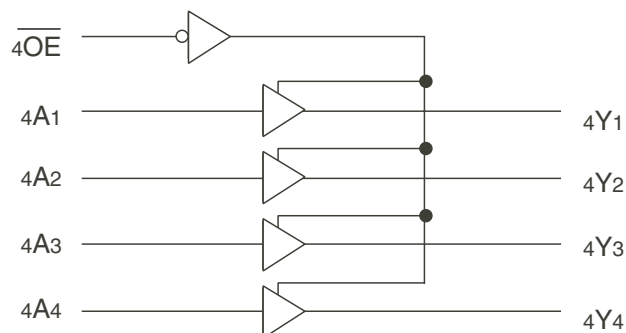
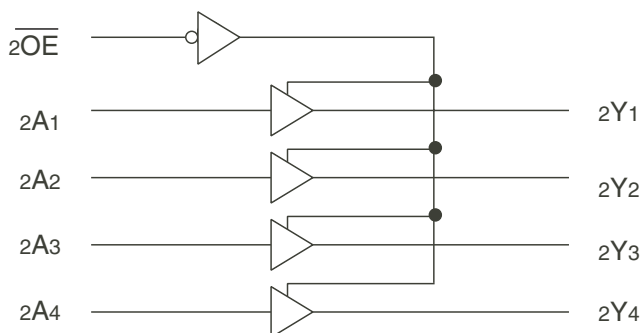
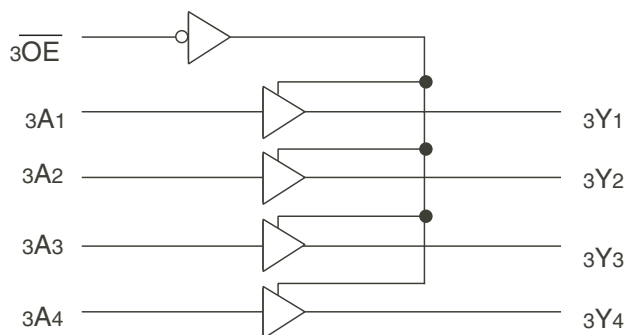
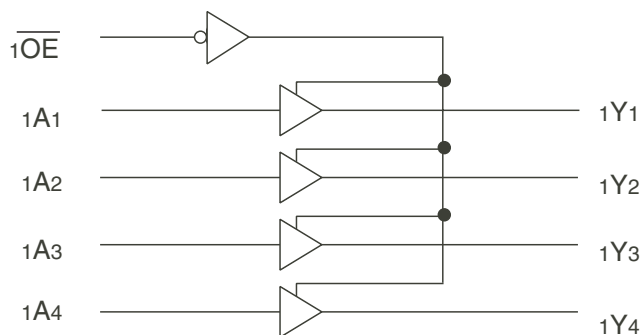

The IDT logo is a registered trademark of Integrated Device Technology, Inc.

PIN CONFIGURATION

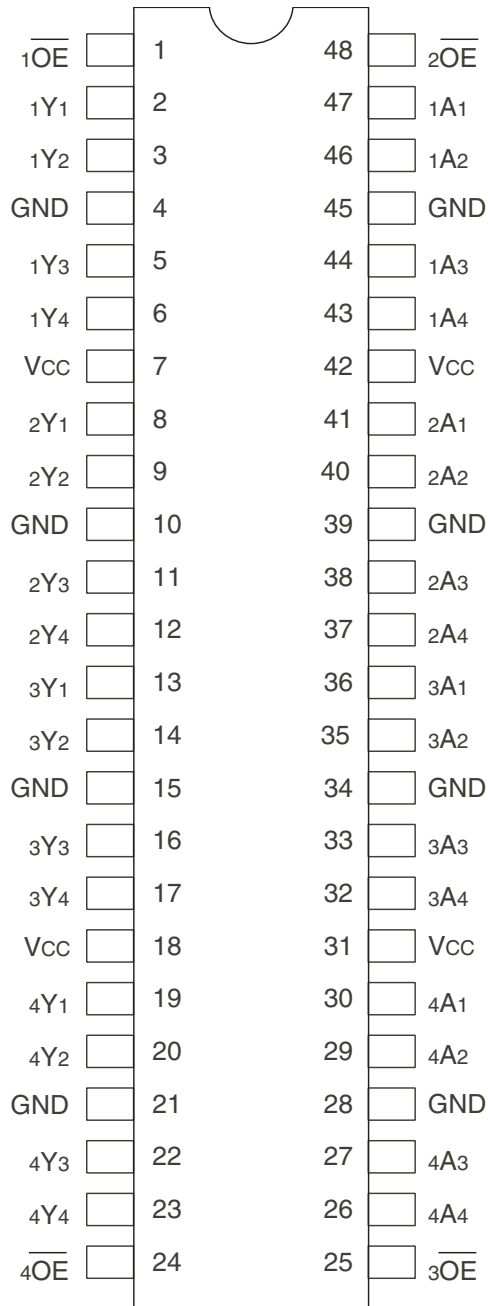

SSOP/ TSSOP/ CERPACK
TOP VIEW

ABSOLUTE MAXIMUM RATINGS⁽¹⁾

Symbol	Description	Max	Unit
VTERM ⁽²⁾	Terminal Voltage with Respect to GND	-0.5 to +7	V
VTERM ⁽³⁾	Terminal Voltage with Respect to GND	-0.5 to VCC+0.5	V
TSTG	Storage Temperature	-65 to +150	°C
IOUT	DC Output Current	-60 to +120	mA

NOTES:

- Stresses greater than those listed under ABSOLUTE MAXIMUM RATINGS may cause permanent damage to the device. This is a stress rating only and functional operation of the device at these or any other conditions above those indicated in the operational sections of this specification is not implied. Exposure to absolute maximum rating conditions for extended periods may affect reliability.
- All device terminals except FCT162XXXT Output and I/O terminals.
- Output and I/O terminals terminals for FCT162XXXT and FCT166XXXT.

CAPACITANCE (TA = +25°C, F = 1.0MHz)

Symbol	Parameter ⁽¹⁾	Conditions	Typ.	Max.	Unit
CIN	Input Capacitance	VIN = 0V	3.5	6	pF
COU	Output Capacitance	VOU = 0V	3.5	8	pF

NOTE:

- This parameter is measured at characterization but not tested.

PIN DESCRIPTION

Pin Names	Description
xOE	3-State Output Enable Inputs (Active LOW)
xAx	Data Inputs
xYx	3-State Outputs

FUNCTION TABLE⁽¹⁾

Inputs		Outputs
xOE	xAx	xYx
L	L	L
L	H	H
H	X	Z

NOTE:

- H = HIGH Voltage Level
X = Don't Care
L = LOW Voltage Level
Z = High-Impedance

DC ELECTRICAL CHARACTERISTICS OVER OPERATING RANGE

Following Conditions Apply Unless Otherwise Specified:

Industrial: $T_A = -40^{\circ}\text{C}$ to $+85^{\circ}\text{C}$, $V_{CC} = 5.0\text{V} \pm 10\%$; Military: $T_A = -55^{\circ}\text{C}$ to $+125^{\circ}\text{C}$, $V_{CC} = 5.0\text{V} \pm 10\%$

Symbol	Parameter	Test Conditions ⁽¹⁾		Min.	Typ. ⁽²⁾	Max.	Unit
V_{IH}	Input HIGH Level	Guaranteed Logic HIGH Level		2	—	—	V
V_{IL}	Input LOW Level	Guaranteed Logic LOW Level		—	—	0.8	V
I_{IH}	Input HIGH Current (Input pins) ⁽⁵⁾	$V_{CC} = \text{Max.}$	$V_I = V_{CC}$	—	—	± 1	μA
	Input HIGH Current (I/O pins) ⁽⁵⁾			—	—	± 1	
I_{IL}	Input LOW Current (Input pins) ⁽⁵⁾		$V_I = \text{GND}$	—	—	± 1	
	Input LOW Current (I/O pins) ⁽⁵⁾			—	—	± 1	
I_{OZH}	High Impedance Output Current (3-State Output pins) ⁽⁵⁾	$V_{CC} = \text{Max.}$	$V_O = 2.7\text{V}$	—	—	± 1	μA
I_{OZL}			$V_O = 0.5\text{V}$	—	—	± 1	
V_{IK}	Clamp Diode Voltage	$V_{CC} = \text{Min.}, I_{IN} = -18\text{mA}$		—	-0.7	-1.2	V
I_{OS}	Short Circuit Current	$V_{CC} = \text{Max.}, V_O = \text{GND}^{(3)}$		-80	-140	-250	mA
V_H	Input Hysteresis	—		—	100	—	mV
I_{CCL} I_{CCH} I_{CCZ}	Quiescent Power Supply Current	$V_{CC} = \text{Max.}$ $V_{IN} = \text{GND or } V_{CC}$		—	5	500	μA

OUTPUT DRIVE CHARACTERISTICS

Symbol	Parameter	Test Conditions ⁽¹⁾		Min.	Typ. ⁽²⁾	Max.	Unit
I_{ODL}	Output LOW Current	$V_{CC} = 5\text{V}, V_{IN} = V_{IH} \text{ or } V_{IL}, V_O = 1.5\text{V}^{(3)}$		60	115	200	mA
I_{ODH}	Output HIGH Current	$V_{CC} = 5\text{V}, V_{IN} = V_{IH} \text{ or } V_{IL}, V_O = 1.5\text{V}^{(3)}$		-60	-115	-200	mA
V_{OH}	Output HIGH Voltage	$V_{CC} = \text{Min}$ $V_{IN} = V_{IH} \text{ or } V_{IL}$	$I_{OH} = -16\text{mA MIL}$ $I_{OH} = -24\text{mA COM'L}$	2.4	3.3	—	V
V_{OL}	Output LOW Voltage	$V_{CC} = \text{Min}$ $V_{IN} = V_{IH} \text{ or } V_{IL}$	$I_{OH} = 16\text{mA MIL}$ $I_{OH} = 24\text{mA COM'L}$	—	0.3	0.55	V

NOTES:

1. For conditions shown as Min. or Max., use appropriate value specified under Electrical Characteristics for the applicable device type.
2. Typical values are at $V_{CC} = 5.0\text{V}$, $+25^{\circ}\text{C}$ ambient.
3. Not more than one output should be shorted at one time. Duration of the test should not exceed one second.
4. Duration of the condition can not exceed one second.
5. This test limit for this parameter is $\pm 5\mu\text{A}$ at $T_A = -55^{\circ}\text{C}$.

POWER SUPPLY CHARACTERISTICS

Symbol	Parameter	Test Conditions ⁽¹⁾		Min.	Typ. ⁽²⁾	Max.	Unit
ΔI_{CC}	Quiescent Power Supply Current TTL Inputs HIGH	$V_{CC} = \text{Max.}$ $V_{IN} = 3.4V^{(3)}$		—	0.5	1.5	mA
I_{CCD}	Dynamic Power Supply Current ⁽⁴⁾	$V_{CC} = \text{Max.}$ Outputs Open $\overline{xO\bar{E}} = \text{GND}$ One Input Toggling 50% Duty Cycle	$V_{IN} = V_{CC}$ $V_{IN} = \text{GND}$	—	60	100	$\mu\text{A}/\text{MHz}$
I_C	Total Power Supply Current ⁽⁶⁾	$V_{CC} = \text{Max.}$ Outputs Open $f_i = 10\text{MHz}$ 50% Duty Cycle $\overline{xO\bar{E}} = \text{GND}$ One Bit Toggling	$V_{IN} = V_{CC}$ $V_{IN} = \text{GND}$	—	0.6	1.5	mA
			$V_{IN} = 3.4V$ $V_{IN} = \text{GND}$	—	0.9	2.3	
		$V_{CC} = \text{Max.}$ Outputs Open $f_i = 2.5\text{MHz}$ 50% Duty Cycle $\overline{xO\bar{E}} = \text{GND}$ Sixteen Bits Toggling	$V_{IN} = V_{CC}$ $V_{IN} = \text{GND}$	—	2.4	4.5 ⁽⁵⁾	
			$V_{IN} = 3.4V$ $V_{IN} = \text{GND}$	—	6.4	16.5 ⁽⁵⁾	

NOTES:

1. For conditions shown as Min. or Max., use appropriate value specified under Electrical Characteristics for the applicable device type.

2. Typical values are at $V_{CC} = 5.0V$, $+25^\circ\text{C}$ ambient.

3. Per TTL driven input ($V_{IN} = 3.4V$). All other inputs at V_{CC} or GND.

4. This parameter is not directly testable, but is derived for use in Total Power Supply Calculations.

5. Values for these conditions are examples of the I_{CC} formula. These limits are guaranteed but not tested.

6. $I_C = I_{\text{QUIESCENT}} + I_{\text{INPUTS}} + I_{\text{DYNAMIC}}$

$I_C = I_{CC} + \Delta I_{CC} D_H N_T + I_{CCD} (f_C N_{CP}/2 + f_i N_i)$

$I_{CC} = \text{Quiescent Current (} I_{CC1}, I_{CC2} \text{ and } I_{CC3}\text{)}$

$\Delta I_{CC} = \text{Power Supply Current for a TTL High Input (} V_{IN} = 3.4V\text{)}$

$D_H = \text{Duty Cycle for TTL Inputs High}$

$N_T = \text{Number of TTL Inputs at } D_H$

$I_{CCD} = \text{Dynamic Current caused by an Input Transition Pair (HLH or LHL)}$

$f_C = \text{Clock Frequency for Register Devices (Zero for Non-Register Devices)}$

$N_{CP} = \text{Number of Clock Inputs at } f_C$

$f_i = \text{Input Frequency}$

$N_i = \text{Number of Inputs at } f_i$

SWITCHING CHARACTERISTICS OVER OPERATING RANGE

Symbol	Parameter	Condition ⁽¹⁾	74FCT162244AT		74FCT162244CT		74FCT162244ET		Unit
			Min. ⁽²⁾	Max.	Min. ⁽²⁾	Max.	Min. ⁽²⁾	Max.	
t _{PLH} t _{PHL}	Propagation Delay xAx to xYx	C _L = 50pF R _L = 500Ω	1.5	4.8	1.5	4.1	1.5	3.2	ns
t _{PZH} t _{PZL}	Output Enable Time		1.5	6.2	1.5	5.8	1.5	4.4	ns
t _{PHZ} t _{PLZ}	Output Disable Time		1.5	5.6	1.5	5.2	1.5	3.6	ns
tsk(o)	Output Skew ⁽³⁾		—	0.5	—	0.5	—	0.5	ns

Symbol	Parameter	Condition ⁽¹⁾	54FCT162244T		54FCT162244AT		54FCT162244CT		Unit
			Min. ⁽²⁾	Max.	Min. ⁽²⁾	Max.	Min. ⁽²⁾	Max.	
t _{PLH} t _{PHL}	Propagation Delay xAx to xYx	C _L = 50pF R _L = 500Ω	1.5	7	1.5	5.1	1.5	4.6	ns
t _{PZH} t _{PZL}	Output Enable Time		1.5	8.5	1.5	6.5	1.5	6.5	ns
t _{PHZ} t _{PLZ}	Output Disable Time		1.5	7.5	1.5	5.9	1.5	5.7	ns
tsk(o)	Output Skew ⁽³⁾		—	0.5	—	0.5	—	0.5	ns

NOTES:

1. See test circuit and waveforms.
2. Minimum limits are guaranteed but not tested on Propagation Delays.
3. Skew between any two outputs, of the same package, switching in the same direction. This parameter is guaranteed by design.

TEST CIRCUITS AND WAVEFORMS

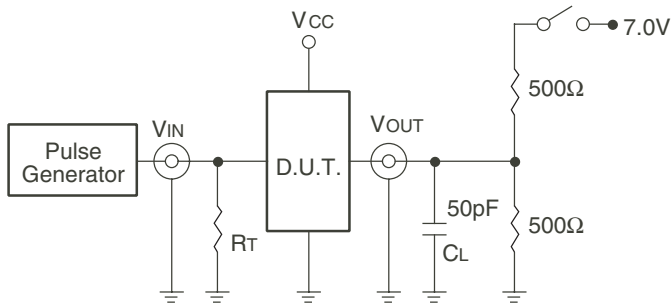

Test Circuit for All Outputs

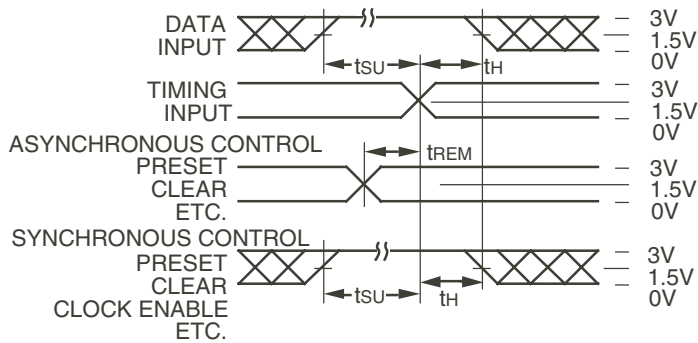

Set-up, Hold, and Release Times

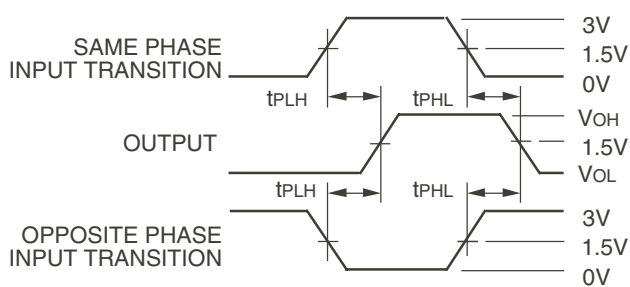

Propagation Delay

SWITCH POSITION

Test	Switch
Open Drain Disable Low Enable Low	Closed
All Other Tests	Open

DEFINITIONS:

CL = Load capacitance: includes jig and probe capacitance.
RT = Termination resistance: should be equal to Zout of the Pulse Generator.

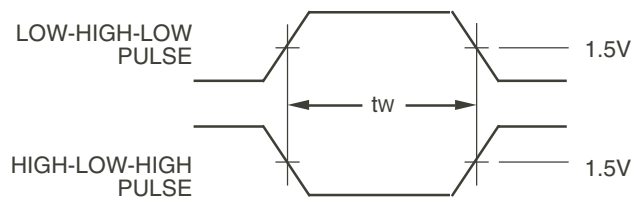

Pulse Width

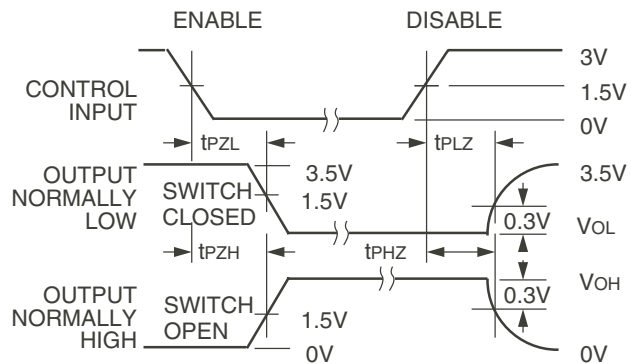

Enable and Disable Times

NOTES:

1. Diagram shown for input Control Enable-LOW and input Control Disable-HIGH.
2. Pulse Generator for All Pulses: Rate \leq 1.0MHz; $t_r \leq$ 2.5ns; $t_f \leq$ 2.5ns.

ORDERING INFORMATION

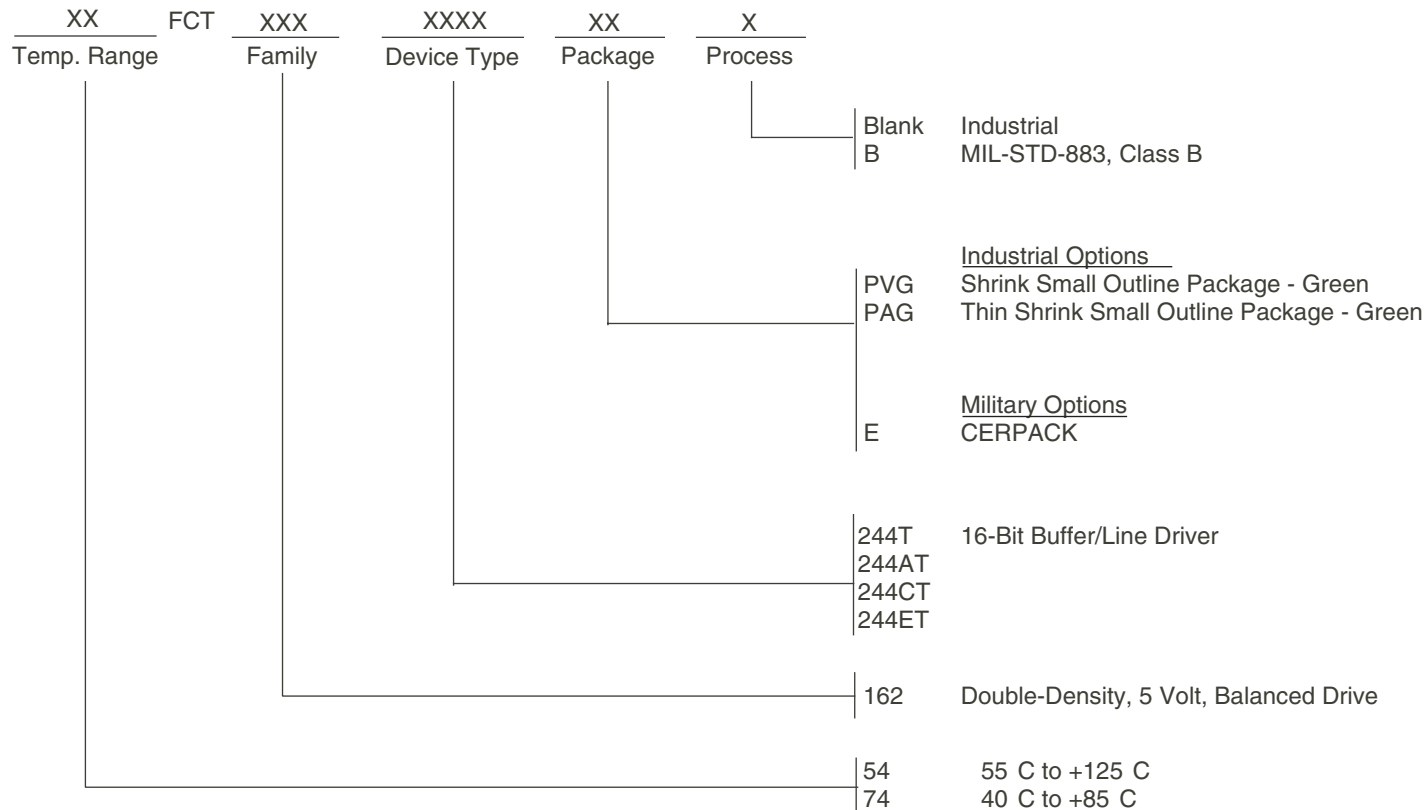

Datasheet Document History

09/06/09 Pg.6 Updated the ordering information by removing the "IDT" notation and non RoHS part.



CORPORATE HEADQUARTERS
 6024 Silver Creek Valley Road
 San Jose, CA 95138

for SALES:
 800-345-7015 or 408-284-8200
 fax: 408-284-2775
 www.idt.com

for Tech Support:
 logichelp@idt.com