

TS3USBA225 USB 2.0 High-Speed (480 Mbps) and Audio Switches with Negative Signal Capability and 1.8-V Logic Compatibility and Power-Down Mode

1 Features

- 2.7-V to 5.0-V Operating Power Supply (VCC)
- MHL/High-Speed USB (480 Mbps) Switch:
 - V I/O Accepts Signals up to 4.5 V (Independent of VCC)
 - 6.5 Ω r_{ON} Typical
 - 3 pF C_{ON} Typical
 - 1.9 GHz Bandwidth (–3 dB)
- Audio Switch:
 - 2.5 Ω r_{ON} Typical
 - Negative Rail Capability down to –1.8 V
 - Low THD: < 0.05%
 - Internal Shunt Resistors for Click-and-Pop Reduction
- 1.8-V Compatible Control Input (SEL1 and SEL2) Threshold
- Minimized Current Consumption (~5 μ A) in Power-Down Mode
- Power-Off Protection: All I/O Pins are High-Z when $V_{CC} = 0$ V
- 12-Pin QFN Package (2 mm \times 1.7 mm, 0.4 mm Pitch)
- ESD Performance Tested per JESD 22
 - 2000 V Human-Body Model (A114-B, Class II)
 - 1000 V Charged-Device Model (C101)

2 Applications

- Cell phones and Smartphones
- Tablet PCs
- Portable Instrumentation
- Digital Still Cameras
- Portable Navigation Devices (GPS)
- USB 2.0, MIPI (CSI/DSI), LVDS Switching

3 Description

The TS3USBA225 is a 2-channel single-pole triple-throw (SP3T) multiplexer that supports USB 2.0 High-Speed (480 Mbps) signals in all 3 differential channels. The first two high-speed differential channels also support Mobile High Definition Link (MHL) signaling with resolution and video frame rates up to 720p, 60 fps and 1080i, 30 fps. The remaining differential channel can also be used as an audio switch that is designed to allow analog audio signals to swing negatively. This configuration allows the system designer to use a common connector for audio and USB 2.0 or MHL data.

The TS3USBA225 has a V_{CC} range of 2.7 V to 5.0 V with the capability to pass true-ground audio signals down to –1.8 V. The device also supports a power-down mode that can be enabled when both SEL1 and SEL2 controls are low to minimize current consumption when no signal is transmitting. The TS3USBA225 also features internal shunt resistors on the audio path to reduce clicks and pops that may be heard when the audio switches are selected.

Simplified Block Diagram

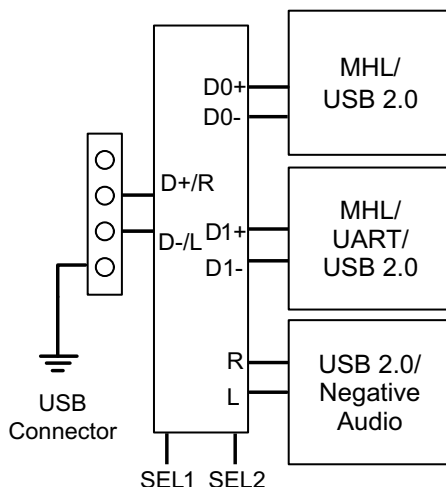

Device Information⁽¹⁾

PART NUMBER	PACKAGE	BODY SIZE (NOM)
TS3USBA225	UQFN (12)	2.00 mm \times 1.70 mm

(1) For all available packages, see the orderable addendum at the end of the data sheet.



Table of Contents

1 Features 1 2 Applications 1 3 Description 1 4 Revision History 2 5 Pin Configuration and Functions 3 6 Specifications 4 6.1 Absolute Maximum Ratings 4 6.2 ESD Ratings 4 6.3 Recommended Operating Conditions 5 6.4 Thermal Information 5 6.5 Electrical Characteristics 6 6.6 Dynamic Characteristics 7 6.7 Typical Characteristics 8 7 Detailed Description 10 7.1 Overview 10 7.2 Functional Block Diagram 10	7.3 Feature Description 10 7.4 Device Functional Modes 11 8 Application and Implementation 12 8.1 Application Information 12 8.2 Typical Application 12 9 Power Supply Recommendations 14 10 Layout 14 10.1 Layout Guidelines 14 10.2 Layout Example 15 11 Device and Documentation Support 16 11.1 Community Resources 16 11.2 Trademarks 16 11.3 Electrostatic Discharge Caution 16 11.4 Glossary 16 12 Mechanical, Packaging, and Orderable Information 16
--	--

4 Revision History

NOTE: Page numbers for previous revisions may differ from page numbers in the current version.

Changes from Revision B (July 2012) to Revision C	Page
• Added <i>Device Information</i> table, <i>ESD Ratings</i> table, <i>Thermal Information</i> table, <i>Detailed Description</i> section, <i>Application and Implementation</i> section, <i>Power Supply Recommendations</i> section, <i>Layout</i> section, <i>Device and Documentation Support</i> section, and <i>Mechanical, Packaging, and Orderable Information</i> section.....	1
• Correct typographical errors to align datasheet information.	1
• Changed "Negative Rail Capability -1.8 V to VCC" to "Negative Rail Capability down to -1.8 V" in Features.	1
• Updated <i>Recommended Operating Conditions</i> table.	5
• Updated <i>Typical Characteristics</i> graphs.	9

Changes from Revision A (April 2012) to Revision B	Page
• Updated Application Block Diagrams.	1
• Updated MIN value in the Absolute Maximum Ratings table for V_R , V_L	4
• Updated MIN value in the <i>Recommended Operating Conditions</i> table for V_R , V_L	5

Changes from Original (October 2011) to Revision A	Page
• Added MHL specification to datasheet.	1
• Updated Application Block Diagrams.	1
• Added MHL Eye Pattern graphics.	13

5 Pin Configuration and Functions

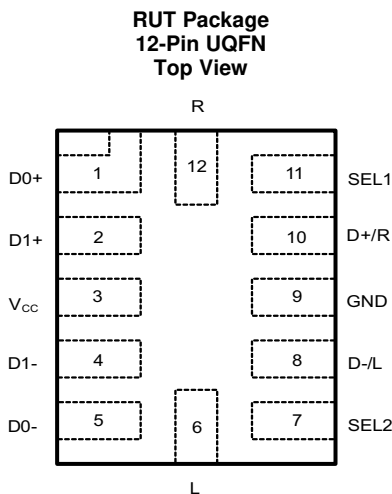

Pin Functions

PIN		I/O	DESCRIPTION
NAME	NO.		
D0+	1	I/O	MHL/USB/UART Data 1 (Differential +)
D1+	2	I/O	MHL/USB/UART Data 2 (Differential +)
V _{CC}	3	-	Power supply
D1-	4	I/O	MHL/USB/UART Data 2 (Differential -)
D0-	5	I/O	MHL/USB/UART Data 1 (Differential -)
L	6	I/O	USB-/Left Channel Audio
SEL2	7	I	Control Input Select Line 2. The default state for SEL2 is LOW.
D-/L	8	I/O	MHL/USB/UART/Audio Common Connector
GND	9	-	Ground
D+/R	10	I/O	MHL/USB/UART/Audio Common Connector
SEL1	11	I	Control Input Select Line 1. The default state for SEL1 is LOW.
R	12	I/O	USB+/Right Channel Audio

Function Table

SEL1	SEL2	V _{CC}	L,R	D0+, D0-	D1+, D1-	MODE
X	X	L	OFF	OFF	OFF	Hi-Z Mode
L	L	H	OFF	OFF	OFF	Power-Down Mode
L	H	H	OFF ⁽¹⁾	ON	OFF	MHL/USB Mode 1
H	L	H	ON	OFF	OFF	USB/Audio Mode
H	H	H	OFF ⁽¹⁾	OFF	ON	MHL/USB Mode 2

(1) 100 Ω shunt resistors are enabled in this state.

6 Specifications

6.1 Absolute Maximum Ratings⁽¹⁾⁽²⁾⁽³⁾

over operating free-air temperature range (unless otherwise noted)

		MIN	MAX	UNIT
V_{CC}	Supply voltage	-0.3	6.0	V
V_{D0+} , V_{D0-} , V_{D1+} , V_{D1-}	High speed differential signal voltage	-0.3	4.6	V
V_R , V_L	Audio signal voltage	-1.9	4.6	V
I_K	Analog port diode current $V_{I/O+}, V_{I/O-} < 0$	-50		mA
V_I	Digital input voltage (SEL1, SEL2)	-0.3	6.0	V
I_{IK}	Digital logic input clamp current ⁽³⁾ $V_I < 0$	-50		
I_{CC}	Continuous current through VCC		100	mA
I_{GND}	Continuous current through GND	-100		mA
T_{stg}	Storage temperature	-65	150	°C

- (1) Stresses beyond those listed under *Absolute Maximum Ratings* may cause permanent damage to the device. These are stress ratings only, and functional operation of the device at these or any other conditions beyond those indicated under *Recommended Operating Conditions* is not implied. Exposure to absolute-maximum-rated conditions for extended periods may affect device reliability.
- (2) The algebraic convention, whereby the most negative value is a minimum and the most positive value is a maximum.
- (3) All voltages are with respect to ground, unless otherwise specified.

6.2 ESD Ratings

		VALUE	UNIT
$V_{(ESD)}$	Electrostatic discharge	Human-body model (HBM), per ANSI/ESDA/JEDEC JS-001 ⁽¹⁾	±2000
		Charged-device model (CDM), per JEDEC specification JESD22-C101 ⁽²⁾	±1000

- (1) JEDEC document JEP155 states that 500-V HBM allows safe manufacturing with a standard ESD control process. Manufacturing with less than 500-V HBM is possible with the necessary precautions.
- (2) JEDEC document JEP157 states that 250-V CDM allows safe manufacturing with a standard ESD control process. Manufacturing with less than 250-V CDM is possible with the necessary precautions.

6.3 Recommended Operating Conditions

		MIN	MAX	UNIT
V_{CC}	Supply voltage range	2.7	5.0	V
$V_{D0+}, V_{D0-}, V_{D1+}, V_{D1-}$	High speed differential signal voltage range	0	4.5	V
V_R, V_L	Audio signal voltage range when not in power-down mode	-1.8	4.3 V or $V_{CC}^{(1)}$	V
	Audio signal voltage range when in power-down mode	-1	1	
I_K	Analog port diode current	-50		mA
	$V_{I/O+}, V_{I/O-} < 0$			
V_I	Digital input voltage range (SEL1, SEL2)	0	V_{CC}	V
T_A	Operating free-air temperature	-40	85	°C

(1) This rating is exclusive and the voltage on the pins must not exceed either 4.3 V or V_{CC} . E.g. if $V_{CC} = 3.3$ V the voltage on the pin must not exceed 3.3 V and if V_{CC} is = 5.0 V the voltage on the pin must not exceed 4.3 V.

6.4 Thermal Information

THERMAL METRIC ⁽¹⁾		TS3USBA225	UNIT
		RUT (UQFN)	
		12 PINS	
$R_{\theta JA}$	Junction-to-ambient thermal resistance	118.6	°C/W
$R_{\theta JC(top)}$	Junction-to-case (top) thermal resistance	45.1	°C/W
$R_{\theta JB}$	Junction-to-board thermal resistance	47.9	°C/W
Ψ_{JT}	Junction-to-top characterization parameter	0.7	°C/W
Ψ_{JB}	Junction-to-board characterization parameter	47.9	°C/W

(1) For more information about traditional and new thermal metrics, see the *Semiconductor and IC Package Thermal Metrics* application report, [SPRA953](#).

6.5 Electrical Characteristics

 $T_A = -40^{\circ}\text{C}$ to 85°C , typical values are at $V_{CC} = 3.3\text{ V}$, $T_A = 25^{\circ}\text{C}$ (unless otherwise noted)

PARAMETER		TEST CONDITIONS		MIN	TYP	MAX	UNIT
MHL/USB SWITCH							
r_{on}	ON-state resistance	$V_{CC} = 3.0\text{ V}$	$V_{I/O+,I/O-} = 0.4\text{ V}$, $I_{ON} = 15\text{ mA}$		6.5	7.5	Ω
Δr_{on}	ON-state resistance match between channels	$V_{CC} = 3.0\text{ V}$	$V_{I/O+,I/O-} = 1.7\text{ V}$, $I_{ON} = 15\text{ mA}$		0.1		Ω
r_{on} (flat)	ON-state resistance flatness	$V_{CC} = 3.0\text{ V}$	$V_{I/O+,I/O-} = 0$ to 1.7 V , $I_{ON} = 15\text{ mA}$		0.5		Ω
I_{OZ}	OFF leakage current	$V_{CC} = 3.6\text{ V}$	Switch OFF, $V_{I/O+,I/O-} = 0$ to 3.6 V , $V_{D+/R, D-/L} = 0\text{ V}$			1	μA
USB/AUDIO SWITCH							
r_{on}	ON-state resistance	$V_{CC} = 3.0\text{ V}$	SEL1 = High, SEL2 = Low, $V_{L/R} = -1.8\text{ V}$, 0 V , 0.7 V , $I_{ON} = -26\text{ mA}$		2.5	3.5	Ω
Δr_{on}	ON-state resistance match between channels	$V_{CC} = 3.0\text{ V}$	SEL1 = High, SEL2 = Low, $V_{L/R} = 0.7\text{ V}$, $I_{ON} = -26\text{ mA}$		0.1		Ω
r_{on} (flat)	ON-state resistance flatness	$V_{CC} = 3.0\text{ V}$	SEL1 = High, SEL2 = Low, $V_{L/R} = -1.8\text{ V}$, 0 V , 0.7 V , $I_{ON} = -26\text{ mA}$		0.1		Ω
r_{SHUNT}	Shunt resistance	$V_{CC} = 2.7\text{ V}$ to 5.0 V	Switch OFF, $V_{L/R} = 0.7\text{ V}$, $I_{SHUNT} = 10\text{ mA}$		100	200	Ω
DIGITAL CONTROL INPUTS (SEL1, SEL2)							
V_{IH}	Input logic high	$V_{CC} = 3.3\text{ V}$ to 5.0 V		1.3			V
V_{IL}	Input logic low	$V_{CC} = 2.7\text{ V}$ to 3.3 V			0.25		V
		$V_{CC} = 3.3\text{ V}$ to 5.0 V			0.4		V
I_{IN}	Input leakage current	$V_{CC} = 2.7\text{ V}$ to 5.0 V	$V_{IN} = 5.0\text{ V}$			± 3	μA
			$V_{IN} = 0\text{ V}$			± 0.1	μA
r_{PD1} , r_{PD2}	Internal pulldown resistance	$V_{CC} = 2.7\text{ V}$ to 5.0 V			3		M Ω

6.6 Dynamic Characteristics

 $T_A = -40^\circ\text{C}$ to 85°C , typical values are at $V_{CC} = 3.3\text{ V}$, $T_A = 25^\circ\text{C}$ (unless otherwise noted)

PARAMETER		TEST CONDITIONS		MIN	TYP	MAX	UNIT
MHL/USB SWITCH							
t_{pd}	Propagation Delay	$V_{CC} = 2.7\text{ V}$ or 3.3 V		0.25			ns
t_{ON}	Turn-on time	$R_L = 50\ \Omega$, $C_L = 35\text{ pF}$	$V_{CC} = 2.7\text{ V}$			60	ns
t_{OFF}	Turn-off time	$R_L = 50\ \Omega$, $C_L = 35\text{ pF}$	$V_{CC} = 2.7\text{ V}$			20	ns
$t_{SK(O)}$	Channel-to-channel skew	$V_{CC} = 2.7\text{ V}$ or 3.3 V		15			ps
$t_{SK(P)}$	Skew of opposite transitions of same output	$V_{CC} = 2.7\text{ V}$ or 3.3 V		15			ps
$C_{I/O+(OFF)}$ $C_{I/O-(OFF)}$	OFF capacitance	$V_{CC} = 2.7\text{ V}$ or 3.3 V , $V_{D0+/D0-} = 0$ or 3.3 V	Switch OFF	1			pF
$C_{I/O+(ON)}$ $C_{I/O-(ON)}$	ON capacitance	$V_{CC} = 2.7\text{ V}$ or 3.3 V , $V_{D0+/D0-} = 0$ or 3.3 V	Switch ON	3			pF
C_I	Digital input capacitance	$V_{CC} = 2.7\text{ V}$ or 3.3 V , $V_I = 0$ or 3.3 V		2.5			pF
BW	Bandwidth	$V_{CC} = 2.7\text{ V}$ or 3.3 V , $R_L = 50\ \Omega$	Switch ON	1.9			GHz
O_{ISO}	OFF Isolation	$V_{CC} = 2.7\text{ V}$ or 3.3 V , $R_L = 50\ \Omega$, $f = 240\text{ MHz}$	Switch OFF	-35			dB
X_{TALK}	Crosstalk	$V_{CC} = 2.5\text{ V}$ or 3.3 V , $R_L = 50\ \Omega$, $f = 240\text{ MHz}$	Switch ON	-45			dB
USB/AUDIO SWITCH							
t_{ON}	Turn-on time	$R_L = 50\ \Omega$, $C_L = 35\text{ pF}$	$V_{CC} = 2.7\text{ V}$	40			μs
t_{OFF}	Turn-off time	$R_L = 50\ \Omega$, $C_L = 35\text{ pF}$	$V_{CC} = 2.7\text{ V}$	15			ns
$C_{L(OFF)}$, $C_{R(OFF)}$	L, R OFF capacitance	$V_{CC} = 2.7\text{ V}$ to 4.5 V , $f = 20\text{ kHz}$	Switch OFF	1.0			pF
$C_{L(ON)}$, $C_{R(ON)}$	L, R ON capacitance	$V_{CC} = 2.7\text{ V}$ to 4.5 V , $f = 20\text{ kHz}$	Switch ON	3.5			pF
O_{ISO}	OFF Isolation	$V_{CC} = 3.3\text{ V}$, $R_L = 50\ \Omega$, $f = 20\text{ kHz}$	Switch OFF	-85			dB
X_{TALK}	Crosstalk	$V_{CC} = 3.3\text{ V}$, $R_L = 50\ \Omega$, $f = 20\text{ kHz}$	Switch ON	-95			dB
THD	Total harmonic distortion	$V_{CC} = 3.3\text{ V}$, SEL1 = High, SEL2 = Low, $f = 20\text{ Hz}$ to 20 kHz , $R_L = 600\ \Omega$, $V_{IN} = 2\text{ Vpp}$	Switch ON	0.05%			
SUPPLY							
V_{CC}	Power supply voltage			2.7	5.0		V
I_{CC}	Positive supply current	$V_{CC} = 2.7\text{ V}$, 3.6 V , 5.0 V $V_{IN} = V_{CC}$ or GND, $V_{I/O} = 0\text{ V}$, Switch ON or OFF		25		50	μA
$I_{CC, PD}$	Positive supply current (Power-Down Mode)	$V_{CC} = 2.7\text{ V}$, 3.6 V , 5.0 V , $V_{I/O} = 0\text{ V}$, SEL1 and SEL2 = Low		3		5	μA
PSRR	Power Supply Rejection Ratio	$V_{CC} = 2.7\text{ V}$, 3.6 V , 5.0 V $V_{IN} = V_{CC} \pm 200\text{ mVpp}$ $R_L = 50\ \Omega$		-60			dB
I_{OFF}	Power off leakage current	$V_{CC} = 0\text{ V}$, D+/R, D-/L, D0+, D0-, D1+, D1-, L, $V_{IN} = 0$ to 4.5 V		± 0.1			μA

6.7 Typical Characteristics

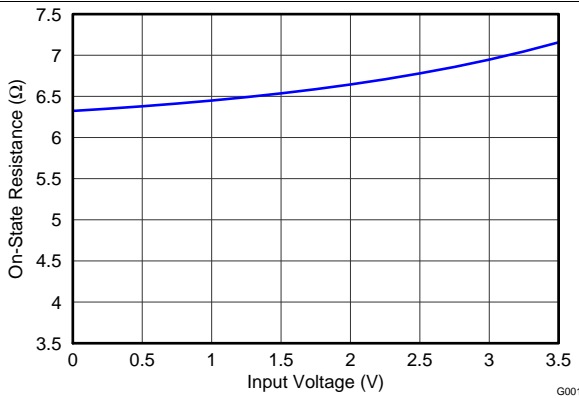

Figure 1. ON Resistance vs V_I for MHL/USB Switch

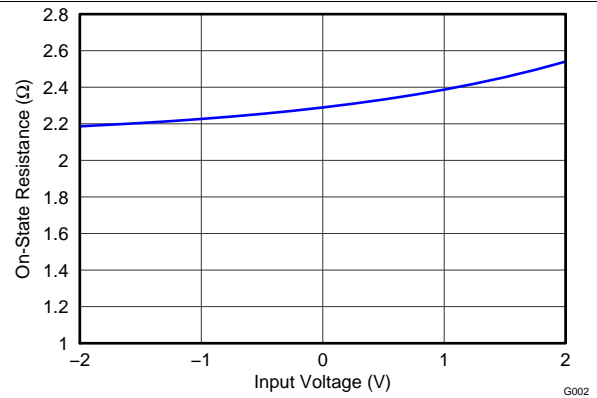

Figure 2. ON Resistance vs V_I for USB/Audio Switch

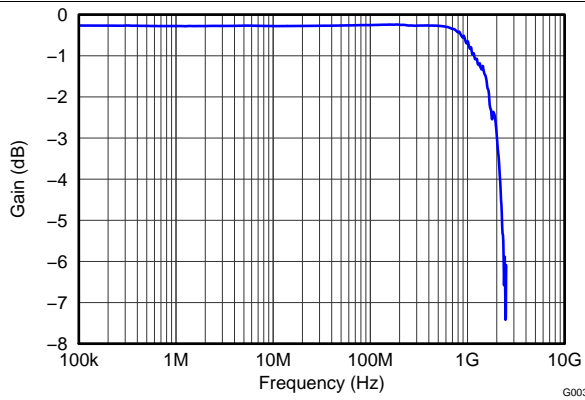

Figure 3. Gain vs Frequency for MHL/USB Switch

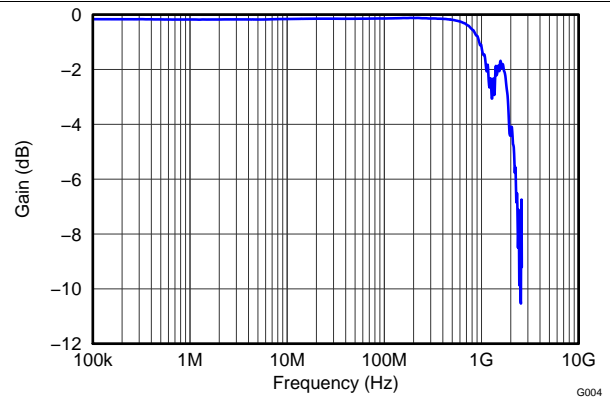

Figure 4. Gain vs Frequency for USB/Audio Switch

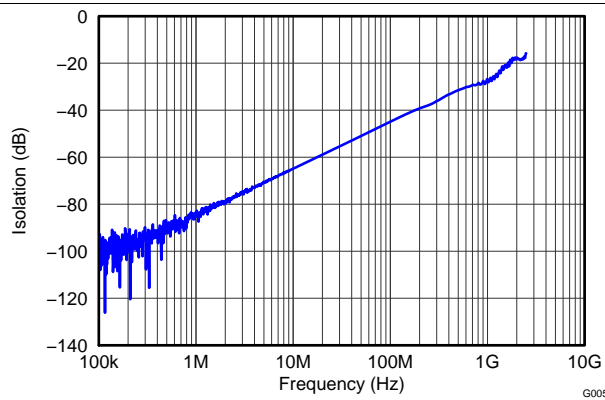

Figure 5. Off Isolation vs Frequency for MHL/USB Switch

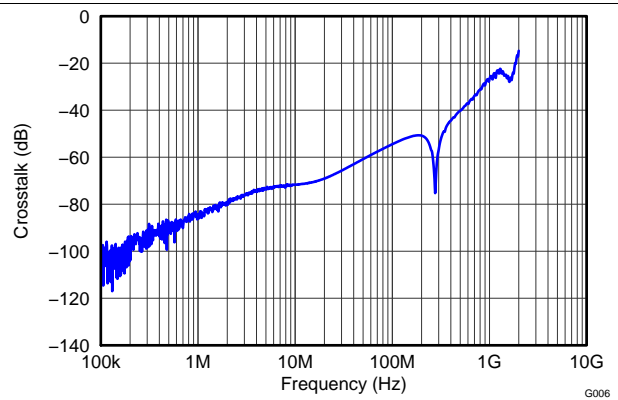
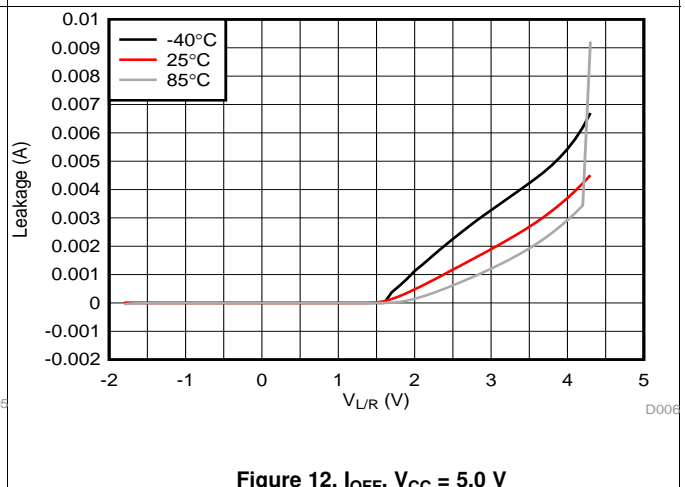
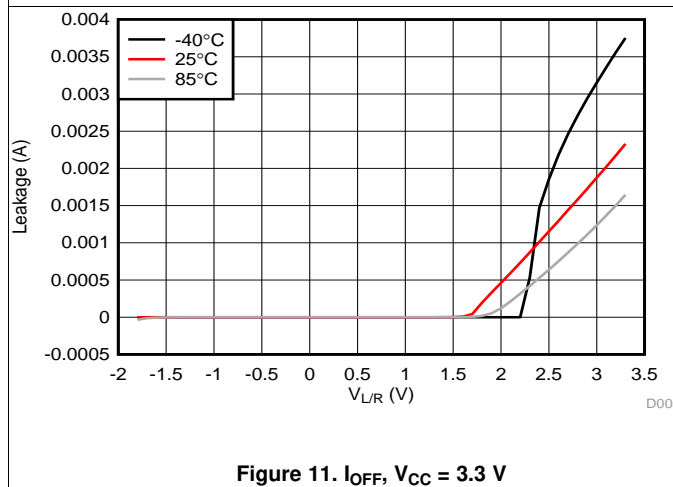
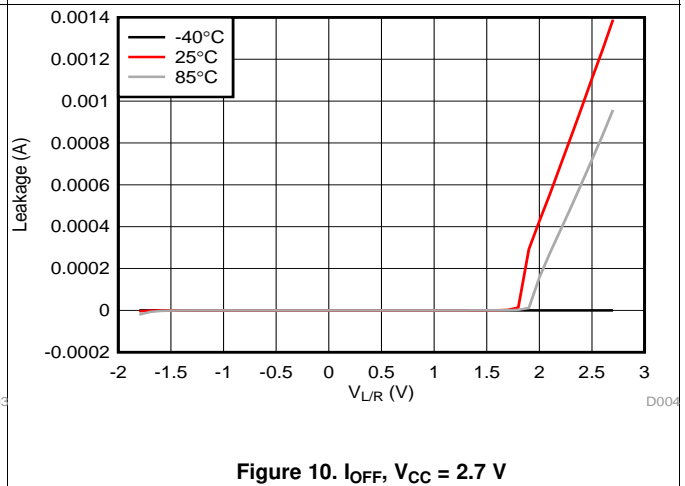
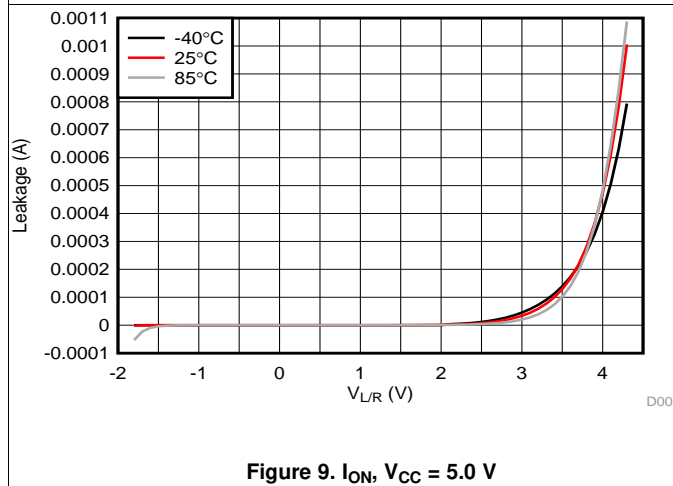
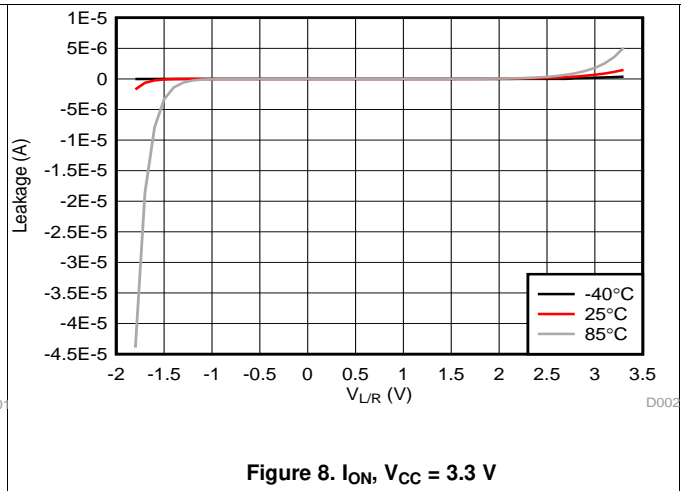
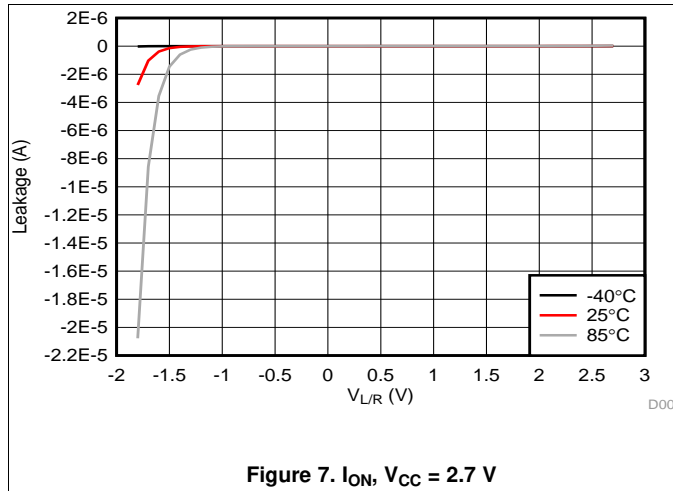

Figure 6. Cross Talk vs Frequency for MHL/USB Switch

Typical Characteristics (continued)



7 Detailed Description

7.1 Overview

The TS3USBA225 is a 2-channel single-pole triple-throw (SP3T) multiplexer that supports USB 2.0 High-Speed (480 Mbps) signals in all 3 differential channels. The first two high-speed differential channels also support Mobile High Definition Link (MHL) signaling with video resolution and frame rates up to 720p, 60 fps and 1080i, 30 fps. The remaining differential channel can also be used as an audio switch that is designed to allow analog audio signals to swing negatively. This configuration allows the system designer to use a common connector for audio and USB 2.0 or MHL data.

The TS3USBA225 has a V_{CC} range of 2.7 V to 5.0 V with the capability to pass true-ground audio signals down to -1.8 V. The device also supports a power-down mode that can be enabled when both SEL controls are low to minimize current consumption when no signal is transmitting. The TS3USBA225 also features internal shunt resistors on the audio path to reduce clicks and pops that may be heard when the audio switches are selected.

7.2 Functional Block Diagram

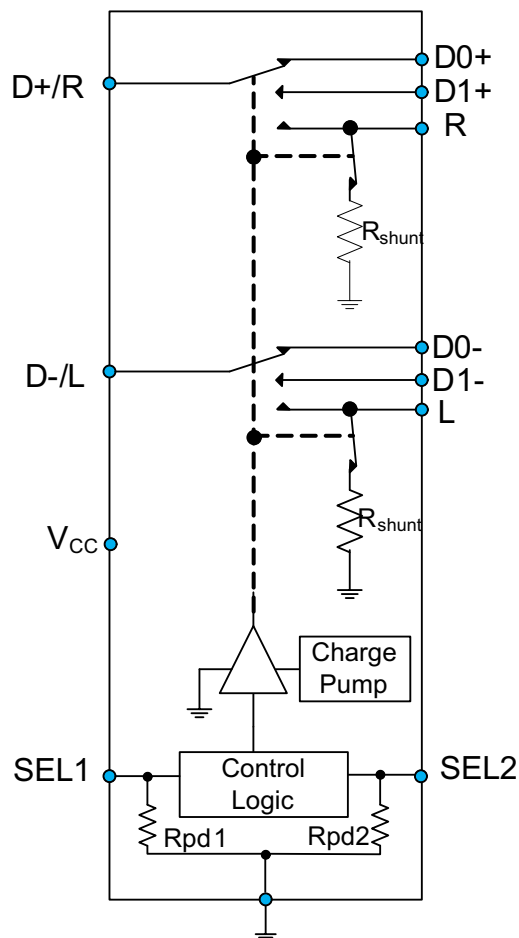

7.3 Feature Description

7.3.1 Click and Pop Reduction

The shunt resistors in the TS3USBA225 automatically discharge any capacitance at the L and R terminals when they are not connected to the common D-/L and D+/R paths. This reduces the audible click-and-pop sounds that occur when switching between audio sources. Audible clicks and pops are caused when a step DC voltage is switched into the speaker. By automatically discharging the side that is not connected, any residual DC voltage is removed, thereby reducing the clicks and pops.

Feature Description (continued)

7.3.2 Negative Signal Swing Capability

The TS3USBA225 has an analog audio path L and R that can support negative signals that pass below ground without distortion. These analog switches operate from -1.8 V to 4.3 V .

7.4 Device Functional Modes

7.4.1 High Impedance (Hi-Z) Mode

The TS3USBA225 has a Hi-Z mode that places the device's signal paths in a high impedance state when there is no power supplied to the TS3USBA225 V_{CC} pin. This mode will isolate the signal bus in a powered off situation so that it may not interfere with other devices that maybe sharing the bus.

7.4.1.1 Power-Down Mode

The TS3USBA225 has a power-down mode that reduces the power consumption to $3\text{ }\mu\text{A}$ when the device is not in use. To put the device in power-down mode and disable the switch, the SEL1 and SEL2 pins must be supplied with a logic low signal.

7.4.2 Device Functional Modes

[Table 1](#) is the function table for the TS3USBA225.

Table 1. Function Table

SEL1	SEL2	V_{CC}	L,R	D0+, D0-	D1+, D1-	MODE
X	X	L	OFF	OFF	OFF	Hi-Z Mode
L	L	H	OFF	OFF	OFF	Power-Down Mode
L	H	H	OFF ⁽¹⁾	ON	OFF	MHL/USB Mode 1
H	L	H	ON	OFF	OFF	USB/Audio Mode
H	H	H	OFF ⁽¹⁾	OFF	ON	MHL/USB Mode 2

(1) $100\text{ }\Omega$ shunt resistors are enabled in this state.

8 Application and Implementation

NOTE

Information in the following applications sections is not part of the TI component specification, and TI does not warrant its accuracy or completeness. TI's customers are responsible for determining suitability of components for their purposes. Customers should validate and test their design implementation to confirm system functionality.

8.1 Application Information

The TS3USBA225 is typically used to route signals from one USB connector to multiple signal paths in a system including an analog audio/negative signal path. All signal paths through the device are unbuffered bidirectional path which can be represented by perfect $0\ \Omega$ impedance wire in an ideal case. All signal paths can handle USB 2.0 signals but the L and R paths are the only paths that can support a negative signal.

8.2 Typical Application

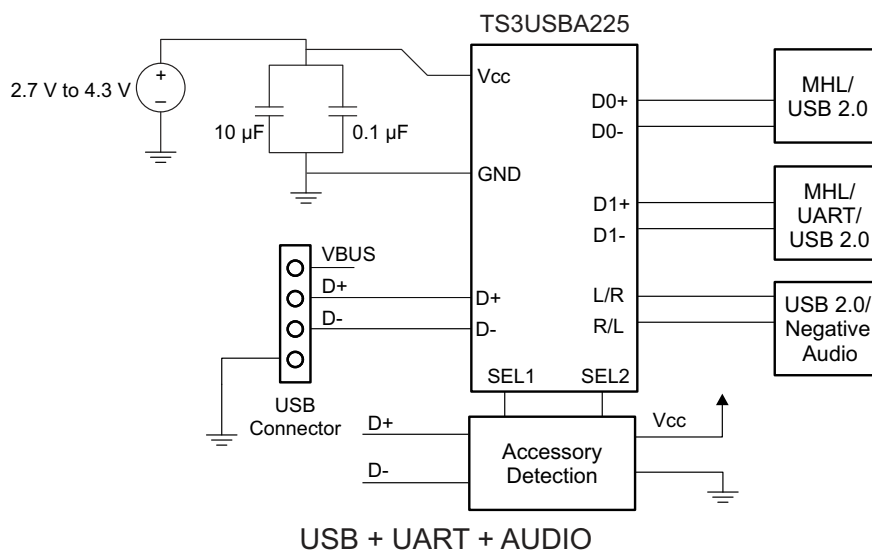

Figure 13. Application Block Diagram

8.2.1 Design Requirements

Design requirements of the USB 1.0, 1.1, and 2.0 standards should be followed.

TI recommends that the digital control pins SEL1 and SEL2 be pulled up to V_{CC} or down to GND to avoid undesired switch positions that could result from the floating logic pin.

8.2.2 Detailed Design Procedure

The TS3USBA225 can be properly operated without any external components. However, it is recommended that unused pins should be connected to ground through a $50\ \Omega$ resistor to prevent signal reflections back into the device.

Typical Application (continued)

8.2.3 Application Curves

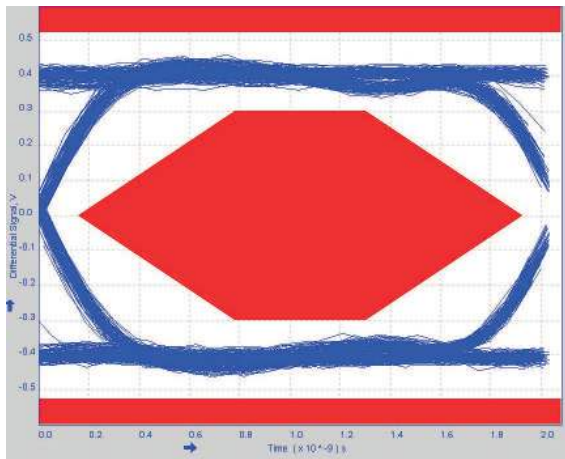

Figure 14. Eye Pattern: 480-Mbps USB 2.0 Eye Pattern (No Switch)

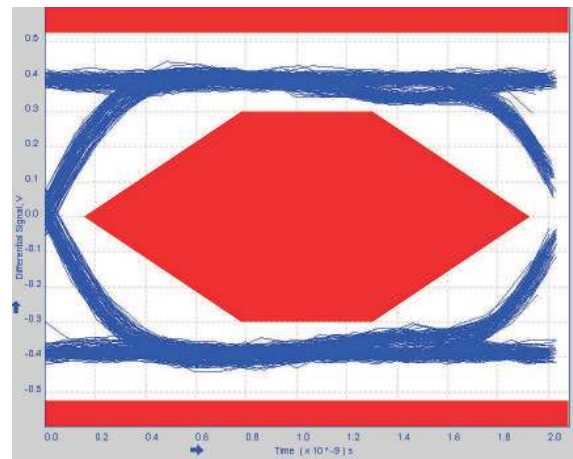

Figure 15. Eye Pattern: 480-Mbps USB 2.0 Eye Pattern for USB Switch

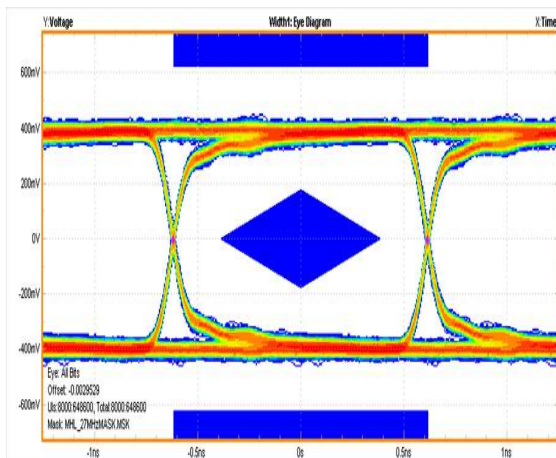

Figure 16. MHL Eye Pattern: 480p 60 fps (No Switch)

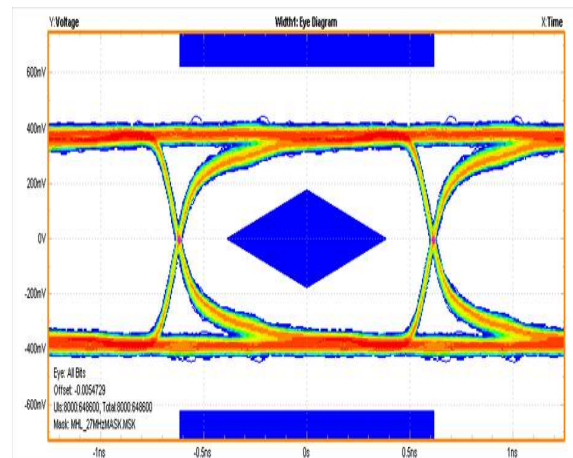

Figure 17. MHL Eye Pattern: 480p 60 fps (With Switch)

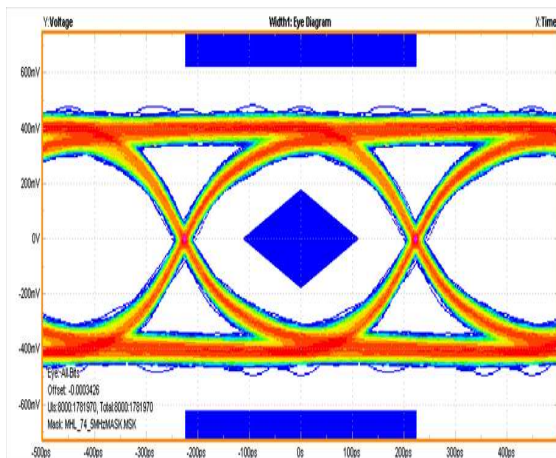

Figure 18. MHL Eye Pattern: 720p 60 fps, 1080i 30fps (No Switch)

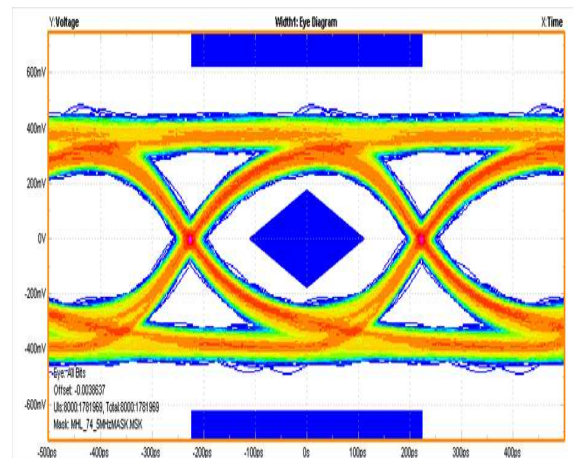

Figure 19. MHL Eye Pattern: 720p 60 fps, 1080i 30fps (With Switch)

9 Power Supply Recommendations

Power to the device is supplied through the V_{CC} pin and should follow the USB 1.0, 1.1, and 2.0 standards. TI recommends placing a bypass capacitor as close as possible to the supply pin V_{CC} to help smooth out low frequency noise to provide better load regulation across the frequency spectrum.

10 Layout

10.1 Layout Guidelines

Place supply bypass capacitors as close to V_{CC} pin as possible and avoid placing the bypass caps near the D+/D– traces.

The high-speed D+/D– traces should always be matched lengths and must be no more than 4 inches; otherwise, the eye diagram performance may be degraded. A high-speed USB connection is made through a shielded, twisted pair cable with a differential characteristic impedance. In layout, the impedance of D+ and D– traces should match the cable characteristic differential impedance for optimal performance.

Route the high-speed USB signals using a minimum of vias and corners which will reduce signal reflections and impedance changes. When a via must be used, increase the clearance size around it to minimize its capacitance. Each via introduces discontinuities in the signal's transmission line and increases the chance of picking up interference from the other layers of the board. Take precaution when designing test points on twisted pair lines; through-hole pins are not recommended.

When it becomes necessary to turn 90°, use two 45° turns or an arc instead of making a single 90° turn. This reduces reflections on the signal traces by minimizing impedance discontinuities.

Do not route USB traces under or near crystals, oscillators, clock signal generators, switching regulators, mounting holes, magnetic devices or IC's that use or duplicate clock signals.

Avoid stubs on the high-speed USB signals because they cause signal reflections. If a stub is unavoidable, then the stub should be less than 200 mm.

Route all high-speed USB signal traces over continuous planes (V_{CC} or GND), with no interruptions.

Avoid crossing over anti-etch, commonly found with plane splits.

Due to high frequencies associated with the USB, a printed circuit board with at least four layers is recommended; two signal layers separated by a ground and power layer as shown in [Figure 20](#).

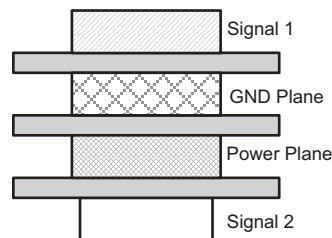

Figure 20. Four-Layer Board Stack-Up

The majority of signal traces should run on a single layer, preferably Signal 1. Immediately next to this layer should be the GND plane, which is solid with no cuts. Avoid running signal traces across a split in the ground or power plane. When running across split planes is unavoidable, sufficient decoupling must be used. Minimizing the number of signal vias reduces EMI by reducing inductance at high frequencies. For more information on layout guidelines, see *High Speed Layout Guidelines (SCAA082)* and *USB 2.0 Board Design and Layout Guidelines (SPRAAR7)*.

10.2 Layout Example

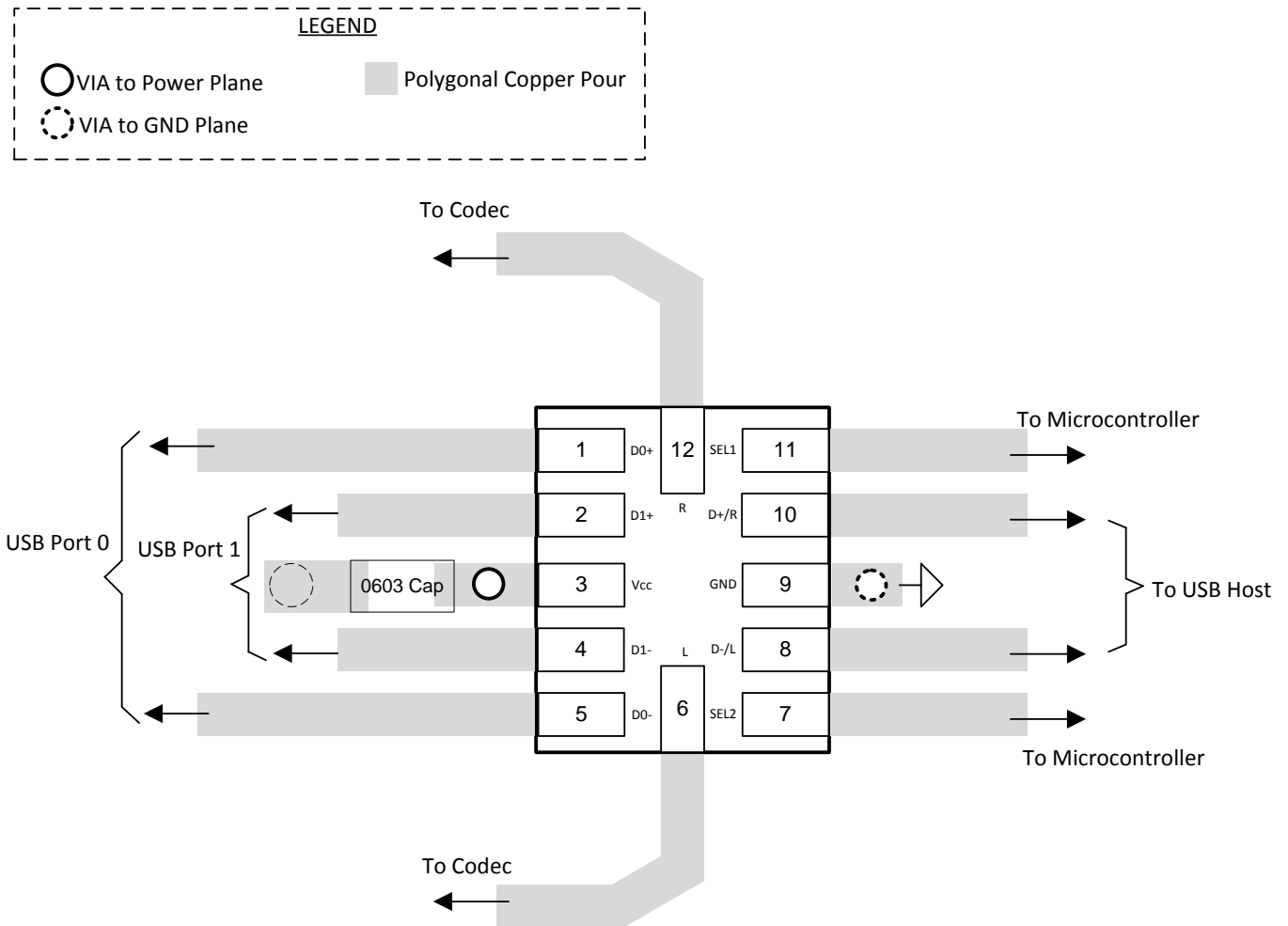

Figure 21. Layout Schematic

11 Device and Documentation Support

11.1 Community Resources

The following links connect to TI community resources. Linked contents are provided "AS IS" by the respective contributors. They do not constitute TI specifications and do not necessarily reflect TI's views; see TI's [Terms of Use](#).

TI E2E™ Online Community *TI's Engineer-to-Engineer (E2E) Community*. Created to foster collaboration among engineers. At e2e.ti.com, you can ask questions, share knowledge, explore ideas and help solve problems with fellow engineers.

Design Support *TI's Design Support* Quickly find helpful E2E forums along with design support tools and contact information for technical support.

11.2 Trademarks

E2E is a trademark of Texas Instruments.
All other trademarks are the property of their respective owners.

11.3 Electrostatic Discharge Caution



These devices have limited built-in ESD protection. The leads should be shorted together or the device placed in conductive foam during storage or handling to prevent electrostatic damage to the MOS gates.

11.4 Glossary

[SLYZ022](#) — *TI Glossary*.

This glossary lists and explains terms, acronyms, and definitions.

12 Mechanical, Packaging, and Orderable Information

The following pages include mechanical, packaging, and orderable information. This information is the most current data available for the designated devices. This data is subject to change without notice and revision of this document. For browser-based versions of this data sheet, refer to the left-hand navigation.

PACKAGING INFORMATION

Orderable Device	Status (1)	Package Type	Package Drawing	Pins	Package Qty	Eco Plan (2)	Lead finish/ Ball material (6)	MSL Peak Temp (3)	Op Temp (°C)	Device Marking (4/5)	Samples
TS3USBA225RUTR	ACTIVE	UQFN	RUT	12	3000	RoHS & Green	NIPDAU NIPDAUAG	Level-1-260C-UNLIM	-40 to 85	(LQ7, LQR)	Samples

(1) The marketing status values are defined as follows:

ACTIVE: Product device recommended for new designs.

LIFEBUY: TI has announced that the device will be discontinued, and a lifetime-buy period is in effect.

NRND: Not recommended for new designs. Device is in production to support existing customers, but TI does not recommend using this part in a new design.

PREVIEW: Device has been announced but is not in production. Samples may or may not be available.

OBSOLETE: TI has discontinued the production of the device.

(2) **RoHS:** TI defines "RoHS" to mean semiconductor products that are compliant with the current EU RoHS requirements for all 10 RoHS substances, including the requirement that RoHS substance do not exceed 0.1% by weight in homogeneous materials. Where designed to be soldered at high temperatures, "RoHS" products are suitable for use in specified lead-free processes. TI may reference these types of products as "Pb-Free".

RoHS Exempt: TI defines "RoHS Exempt" to mean products that contain lead but are compliant with EU RoHS pursuant to a specific EU RoHS exemption.

Green: TI defines "Green" to mean the content of Chlorine (Cl) and Bromine (Br) based flame retardants meet JS709B low halogen requirements of <=1000ppm threshold. Antimony trioxide based flame retardants must also meet the <=1000ppm threshold requirement.

(3) MSL, Peak Temp. - The Moisture Sensitivity Level rating according to the JEDEC industry standard classifications, and peak solder temperature.

(4) There may be additional marking, which relates to the logo, the lot trace code information, or the environmental category on the device.

(5) Multiple Device Markings will be inside parentheses. Only one Device Marking contained in parentheses and separated by a "-" will appear on a device. If a line is indented then it is a continuation of the previous line and the two combined represent the entire Device Marking for that device.

(6) Lead finish/Ball material - Orderable Devices may have multiple material finish options. Finish options are separated by a vertical ruled line. Lead finish/Ball material values may wrap to two lines if the finish value exceeds the maximum column width.

Important Information and Disclaimer:The information provided on this page represents TI's knowledge and belief as of the date that it is provided. TI bases its knowledge and belief on information provided by third parties, and makes no representation or warranty as to the accuracy of such information. Efforts are underway to better integrate information from third parties. TI has taken and continues to take reasonable steps to provide representative and accurate information but may not have conducted destructive testing or chemical analysis on incoming materials and chemicals. TI and TI suppliers consider certain information to be proprietary, and thus CAS numbers and other limited information may not be available for release.

In no event shall TI's liability arising out of such information exceed the total purchase price of the TI part(s) at issue in this document sold by TI to Customer on an annual basis.

TAPE AND REEL INFORMATION

QUADRANT ASSIGNMENTS FOR PIN 1 ORIENTATION IN TAPE



*All dimensions are nominal

Device	Package Type	Package Drawing	Pins	SPQ	Reel Diameter (mm)	Reel Width W1 (mm)	A0 (mm)	B0 (mm)	K0 (mm)	P1 (mm)	W (mm)	Pin1 Quadrant
TS3USBA225RUTR	UQFN	RUT	12	3000	180.0	8.4	1.95	2.3	0.75	4.0	8.0	Q1
TS3USBA225RUTR	UQFN	RUT	12	3000	180.0	9.5	1.9	2.3	0.75	4.0	8.0	Q1

TAPE AND REEL BOX DIMENSIONS

*All dimensions are nominal

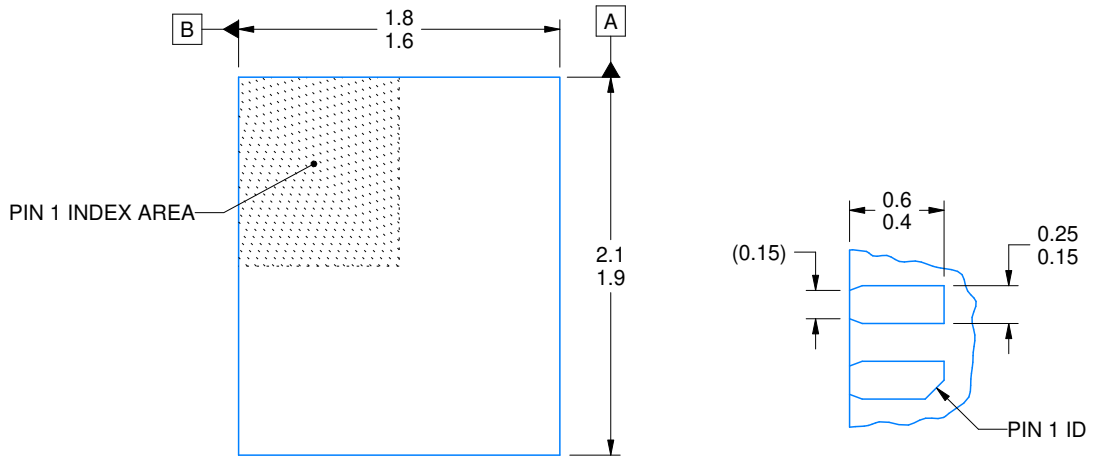
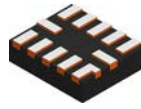
Device	Package Type	Package Drawing	Pins	SPQ	Length (mm)	Width (mm)	Height (mm)
TS3USBA225RUTR	UQFN	RUT	12	3000	202.0	201.0	28.0
TS3USBA225RUTR	UQFN	RUT	12	3000	184.0	184.0	19.0



OPTIONAL TERMINAL & PIN 1 ID

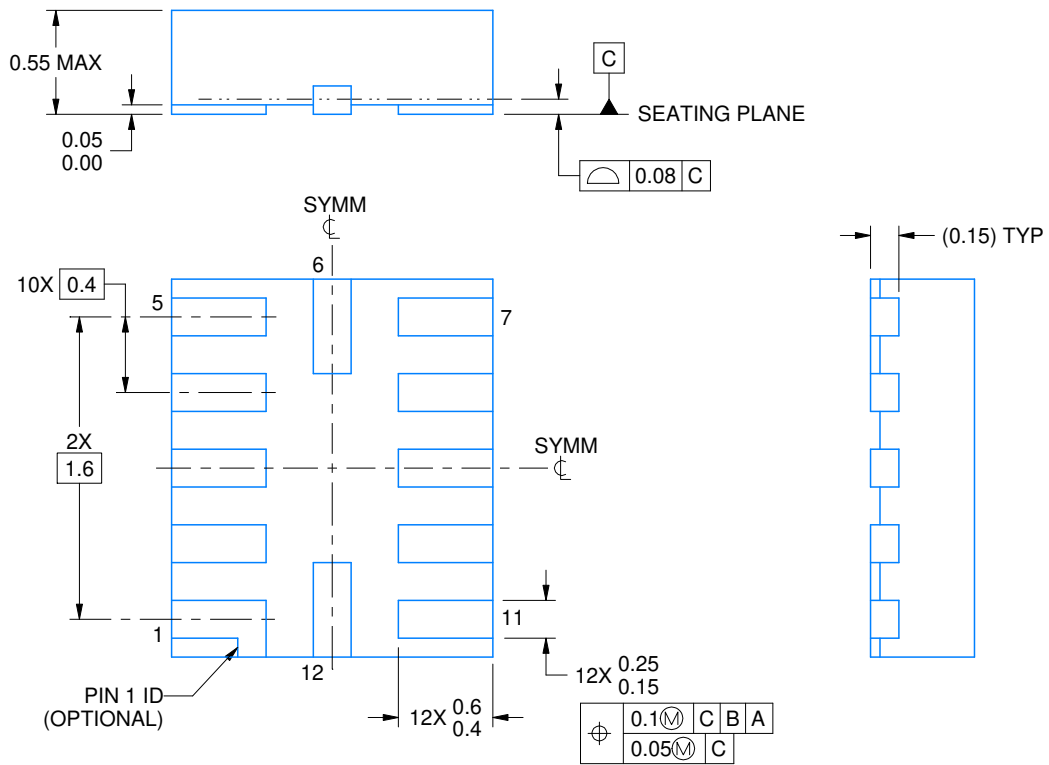

4220310/A 11/2016

NOTES:

1. All linear dimensions are in millimeters. Any dimensions in parenthesis are for reference only. Dimensioning and tolerancing per ASME Y14.5M.
2. This drawing is subject to change without notice.

EXAMPLE BOARD LAYOUT

RUT0012A

UQFN - 0.55 mm max height

PLASTIC QUAD FLATPACK - NO LEAD

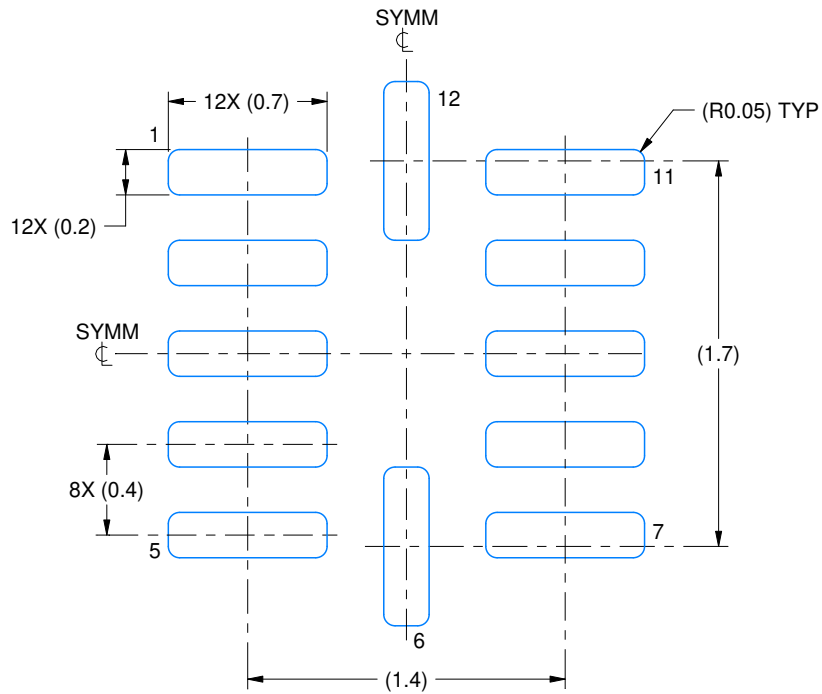

LAND PATTERN EXAMPLE
SCALE:30X

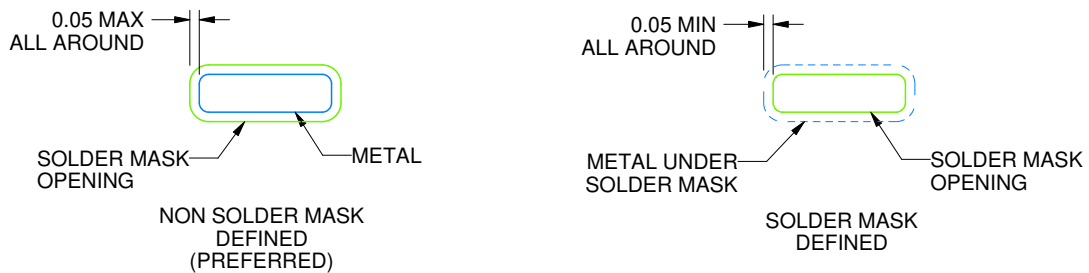

SOLDER MASK DETAILS

4220310/A 11/2016

NOTES: (continued)

3. For more information, see Texas Instruments literature number SLUA271 (www.ti.com/lit/sluea271).

EXAMPLE STENCIL DESIGN

RUT0012A

UQFN - 0.55 mm max height

PLASTIC QUAD FLATPACK - NO LEAD

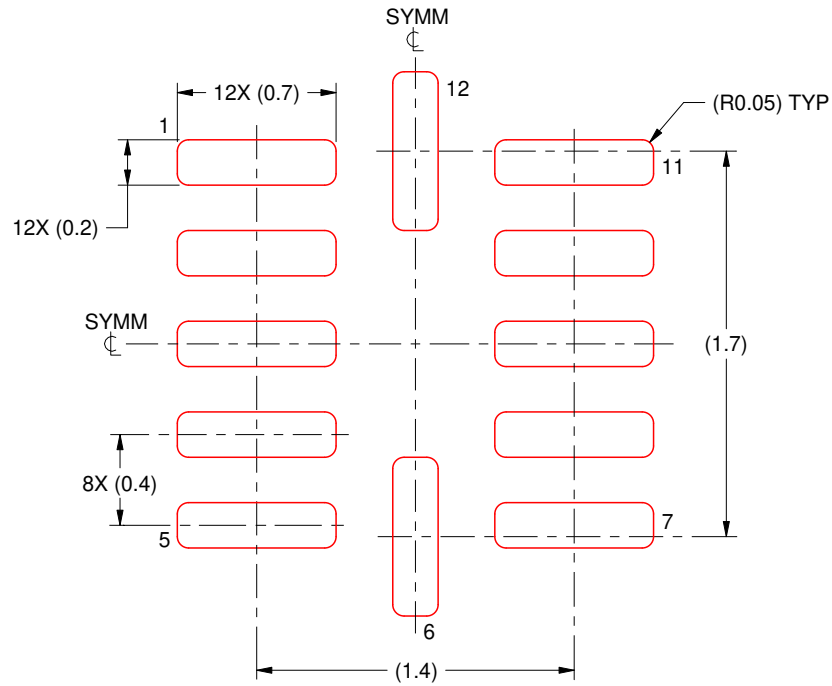

SOLDER PASTE EXAMPLE
BASED ON 0.1 mm THICK STENCIL
SCALE: 30X

4220310/A 11/2016

NOTES: (continued)

4. Laser cutting apertures with trapezoidal walls and rounded corners may offer better paste release. IPC-7525 may have alternate design recommendations.

IMPORTANT NOTICE AND DISCLAIMER

TI PROVIDES TECHNICAL AND RELIABILITY DATA (INCLUDING DATA SHEETS), DESIGN RESOURCES (INCLUDING REFERENCE DESIGNS), APPLICATION OR OTHER DESIGN ADVICE, WEB TOOLS, SAFETY INFORMATION, AND OTHER RESOURCES "AS IS" AND WITH ALL FAULTS, AND DISCLAIMS ALL WARRANTIES, EXPRESS AND IMPLIED, INCLUDING WITHOUT LIMITATION ANY IMPLIED WARRANTIES OF MERCHANTABILITY, FITNESS FOR A PARTICULAR PURPOSE OR NON-INFRINGEMENT OF THIRD PARTY INTELLECTUAL PROPERTY RIGHTS.

These resources are intended for skilled developers designing with TI products. You are solely responsible for (1) selecting the appropriate TI products for your application, (2) designing, validating and testing your application, and (3) ensuring your application meets applicable standards, and any other safety, security, regulatory or other requirements.

These resources are subject to change without notice. TI grants you permission to use these resources only for development of an application that uses the TI products described in the resource. Other reproduction and display of these resources is prohibited. No license is granted to any other TI intellectual property right or to any third party intellectual property right. TI disclaims responsibility for, and you will fully indemnify TI and its representatives against, any claims, damages, costs, losses, and liabilities arising out of your use of these resources.

TI's products are provided subject to [TI's Terms of Sale](#) or other applicable terms available either on [ti.com](https://www.ti.com) or provided in conjunction with such TI products. TI's provision of these resources does not expand or otherwise alter TI's applicable warranties or warranty disclaimers for TI products.

TI objects to and rejects any additional or different terms you may have proposed.

Mailing Address: Texas Instruments, Post Office Box 655303, Dallas, Texas 75265
Copyright © 2023, Texas Instruments Incorporated