

THESE DRAWINGS ARE THE PROPERTY OF QUALTEK ELECTRONICS AND NOT TO BE REPRODUCED FOR OR COMMUNICATED TO A THIRD PARTY WITHOUT THE EXPRESS WRITTEN PERMISSION OF AN OFFICER OF QUALTEK ELECTRONICS.

REVISION			
REV.	DESCRIPTION	DATE	APPROVED
B	Updated Pin Out, Notes and Graphics	10-26-16	LY

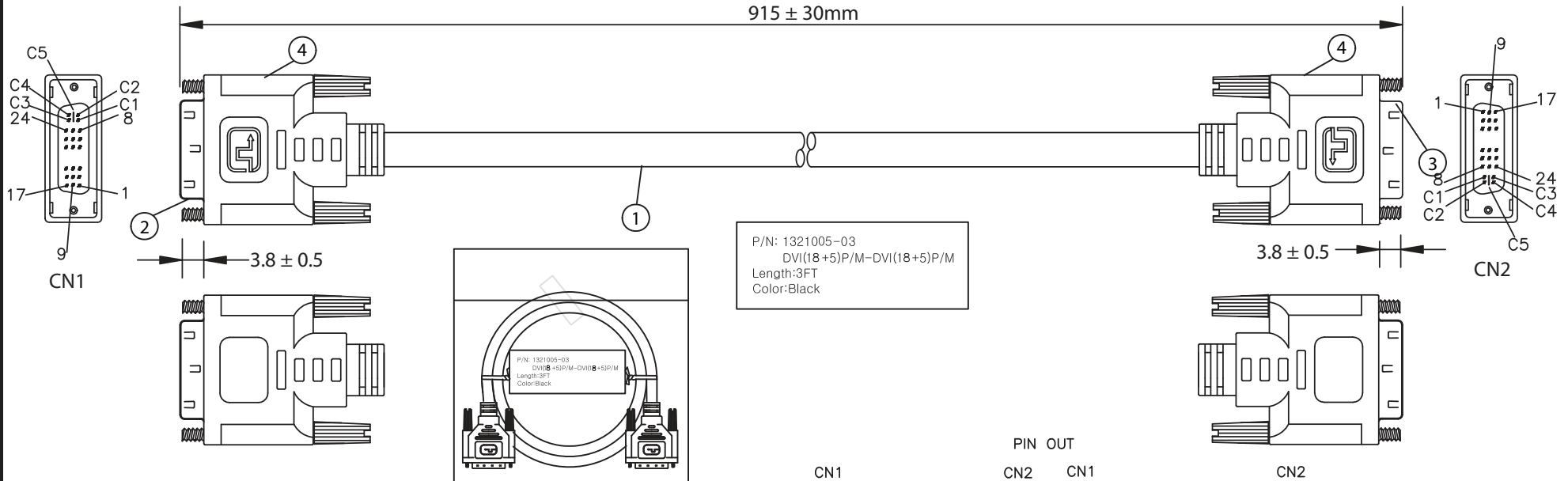

P/N: 1321005-03  
 DVI(18+5)P/M-DVI(18+5)P/M  
 Length:3FT  
 Color:Black

PIN OUT

CN1	CN2	CN1	CN2
1 — WHITE	1 — WHITE	17 — WHITE	17 — WHITE
2 — BROWN	2 — BROWN	18 — GREEN	18 — GREEN
3 — DRAIN	3 — DRAIN	19 — DRAIN	19 — DRAIN
6 — YELLOW	6 — YELLOW	23 — WHITE	23 — WHITE
7 — ORANGE	7 — ORANGE	24 — BLUE	24 — BLUE
8 — BLACK	8 — BLACK	22 — DRAIN	22 — DRAIN
9 — WHITE	9 — WHITE	C1 — RED(CEN)	C1 — RED(CEN)
10 — RED	10 — RED	C2 — GREEN(CEN)	C2 — GREEN(CEN)
11 — DRAIN	11 — DRAIN	C3 — BLUE(CEN)	C3 — BLUE(CEN)
14 — RED	14 — RED	C4 — BLUE	C4 — BLUE
15 — WHITE	15 — WHITE	C5 — GREEN(S)+BLUE(S)+RED(S)	C5 — GREEN(S)+BLUE(S)+RED(S)
16 — VIOLET	16 — VIOLET	SHELL — BRAID & DRAIN	SHELL — BRAID & DRAIN

**NOTES:**

- CABLE: UL20276**  
 (28AWG\*1PR+EAM)\*4+(28AWG\*1C+SAM)\*3+  
 28AWG\*1PR+28AWG\*5C+AEB(AL) 65%  
 OUTER JACKET: BLACK, OD: 8.5 ± 0.2mm
- CONNECTOR: DVI 18+5 MALE**  
 INSULATOR: BLACK  
 PIN G/F  
 NICKEL PLATED SHELL  
 THUMB SCREW: 2.8\*32.5mm #4-40UNC
- CONNECTOR: DVI 18+5 MALE**  
 INSULATOR: BLACK  
 PIN G/F  
 NICKEL PLATED SHELL  
 THUMB SCREW: 2.8\*32.5mm #4-40UNC
- PVC MOLDED: COLOR V398 45P BLACK**
- ELECTRICAL TEST:**  
 <1>.100% OPEN SHORT & MISS WIRE TEST  
 <2>.INSULATION RESISTANCE: DC400V 10M ohm MIN.  
 <3>.CONDUCTOR RESISTANCE: 3 ohm MAX.
- PACKING: 1PC/POLYBAG**

**CONTROLLED**

Dim range (mm)	Tolerance +/- (mm)	<b>Qualtek Electronics Corp.</b>		
		<b>WCI DIVISION</b>		
0-1	0.15	Part Number: <b>1321005-03</b>		
1-6	0.20	<span style="border: 1px solid green; padding: 2px;">RoHS Compliant</span>		
6-18	0.30	Description: <b>DVI (18+5)P/M - DVI (18+5)P/M</b>		
18-50	0.50	UNIT: mm		REV. B
50-120	0.70	Drawn / Date	Checked / Date	Approved / Date
120-250	0.90	B. Grubb 01-11-07	01-11-07	JJH / 01-11-07
250-500	1.20			