



SANYO Semiconductors

DATA SHEET

An ON Semiconductor Company

LA1193M LA1193V

Monolithic Linear IC

For Car Radios

High-Performance FM Front End

Overview

The LA1193M and LA1193V are front-end ICs developed for use in car radios. It incorporates an extremely wide dynamic range mixer and a new AGC system consisting of a dual-system wide-band AGC and a new keyed AGC to provide excellent interference suppression characteristics.

Features

- Improved interference characteristics
 - Expanded mixer input dynamic range
 - Mixer input usable sensitivity : 15dB μ
 - Mixer input I.M. QS : 90dB μ
 (The dynamic range has been increased by 6dB over the earlier LA1175M.)
 - Development of a new wide-band AGC circuit
 - Improved interference characteristics for both nearchannel interference and far-channel interference
 - Improved interference characteristics for the TV band
 - Development of a 3D-AGC system
 - The adjacent channel two-signal interference characteristics can be effectively improved without degrading the strong-field three-signal interference characteristics during keyed AGC operation.
- Improved stability design
 - AGC circuit local oscillator isolation
 - Measures were taken to prevent the deterioration of AMR, noise level, THD and other characteristics during AGC operation.
 - AGC circuit incorrect operation measures
 - The LA1193M provides methods to prevent incorrect operation due to local oscillator injection and loss of DC balance.
- Improved temperature characteristics
 - Conversion gain
 - AGC sensitivity
 - Antenna damping drive output current

■ Any and all SANYO Semiconductor Co.,Ltd. products described or contained herein are, with regard to "standard application", intended for the use as general electronics equipment (home appliances, AV equipment, communication device, office equipment, industrial equipment etc.). The products mentioned herein shall not be intended for use for any "special application" (medical equipment whose purpose is to sustain life, aerospace instrument, nuclear control device, burning appliances, transportation machine, traffic signal system, safety equipment etc.) that shall require extremely high level of reliability and can directly threaten human lives in case of failure or malfunction of the product or may cause harm to human bodies, nor shall they grant any guarantee thereof. If you should intend to use our products for applications outside the standard applications of our customer who is considering such use and/or outside the scope of our intended standard applications, please consult with us prior to the intended use. If there is no consultation or inquiry before the intended use, our customer shall be solely responsible for the use.

■ Specifications of any and all SANYO Semiconductor Co.,Ltd. products described or contained herein stipulate the performance, characteristics, and functions of the described products in the independent state, and are not guarantees of the performance, characteristics, and functions of the described products as mounted in the customer's products or equipment. To verify symptoms and states that cannot be evaluated in an independent device, the customer should always evaluate and test devices mounted in the customer's products or equipment.

SANYO Semiconductor Co., Ltd.

<http://semicon.sanyo.com/en/network>

LA1193M, 1193V

Functions

- Double-balance mixer
- Pin diode drive output
- Differential IF amplifier
- Dual-system wide-band AGC circuit
- Local buffer output
- 3D-AGC system
- FET gate drive AGC output
- IF amplifier gain control pin

Specifications

Maximum Ratings at $T_a = 25^\circ\text{C}$

| Parameter | Symbol | Conditions | Ratings | Unit |
|-----------------------------|------------------|--|-------------|------------------|
| Maximum supply voltage | V_{CC} max | V_{CC} for pins 5 and 17 | 9 | V |
| | V_{CC} max mix | V_{CC} for pins 10 and 11 | 15 | V |
| Allowable power dissipation | P_d max | LA1193M : ($T_a \leq 70^\circ\text{C}$) Mounted on a $41 \times 30 \times 1.1\text{mm}^3$ glass-Epoxy board | 500 | mW |
| | P_d max | LA1193V : ($T_a \leq 70^\circ\text{C}$) Mounted on a $23 \times 36 \times 1.6\text{mm}^3$ glass-Epoxy board | 500 | mW |
| Operating temperature | T_{opr} | * | -40 to +85 | $^\circ\text{C}$ |
| Storage temperature | T_{stg} | | -40 to +125 | $^\circ\text{C}$ |

Note : * Connect a resistor (up to $10\text{k}\Omega$) between pins 17 and 19.

Operating Conditions at $T_a = 25^\circ\text{C}$

| Parameter | Symbol | Conditions | Ratings | Unit |
|--------------------------------|-------------|------------|----------|------|
| Recommended supply voltage | V_{CC} | | 8.0 | V |
| Operating supply voltage range | V_{CC} op | | 7.6 to 9 | V |

Electrical Characteristics at $T_a = 25^\circ\text{C}$, $V_{CC} = 8.0\text{V}$, in the specified test circuit, $f = 88\text{MHz}$, $f_{OSC} = 77.3\text{MHz}$

| Parameter | Symbol | Conditions | Ratings | | | Unit |
|---------------------------|-----------------|---|------------|------------|------------|----------------|
| | | | min | typ | max | |
| Current drain | I_{CCO} | No input, $V_{CONT} = 0\text{V}$ | 19 | 24 | 29 | mA |
| Antenna damping current | ANT-DI | 88MHz, $100\text{dB}\mu$, $V_{CONT} = 4.0\text{V}$ | 7.0 | 9.5 | 12.5 | mA |
| AGC high voltage | V_{AGC-H} | 88MHz, $0\text{dB}\mu$, $V_{CONT} = 4.0\text{V}$ | 7.6 | 7.9 | | V |
| AGC low voltage | V_{AGC-L} | 88MHz, $100\text{dB}\mu$, $V_{CONT} = 4.0\text{V}$ | | 0.4 | 0.9 | V |
| Saturation output voltage | V_{OUT} | 88MHz, $110\text{dB}\mu$, $V_{CONT} = 4.0\text{V}$ | 97 | 110 | | $\text{dB}\mu$ |
| -3dB limiting sensitivity | V_i -Limit | 88MHz, $110\text{dB}\mu$, $V_{CONT} = 4.0\text{V}$ | 78 | 85 | 92 | $\text{dB}\mu$ |
| Conversion gain | A. V | 88MHz, $75\text{dB}\mu$, $V_{CONT} = 4.0\text{V}$ | 98 | 101 | 104 | $\text{dB}\mu$ |
| Local buffer output | V_{OSC} -Buff | No input, no modulation | 105 | 109 | | $\text{dB}\mu$ |
| Narrow V_{AGC-ON} | V-NAGC | 88MHz, $V_{CONT} = 4.0\text{V}$, at an input level such that $V_{AGC-OUT}$ is 2V or less | 73 (76) | 80 (83) | 87 (90) | $\text{dB}\mu$ |
| Wide V_{AGC-ON} | V-WAGC | 88MHz, $V_{CONT} = 0\text{V}$, at an input level such that $V_{AGC-OUT}$ is 2V or less | 97 | 101 | 105 | $\text{dB}\mu$ |
| 3D-AGC-ON | V3D-AGC | 88MHz, V_{CONT} variable, with $95\text{dB}\mu$ being the V_{CONT} voltage input such that $V_{AGC-OUT}$ switches from high to low and 2.0V as the V_{AGC} threshold value. | 0.4 | 0.6 | 0.8 | V |

Note : Values in parenthesis are for LA1193V.

LA1193M, 1193V

Package Dimensions

unit : mm (typ)

3179C

[LA1193V]

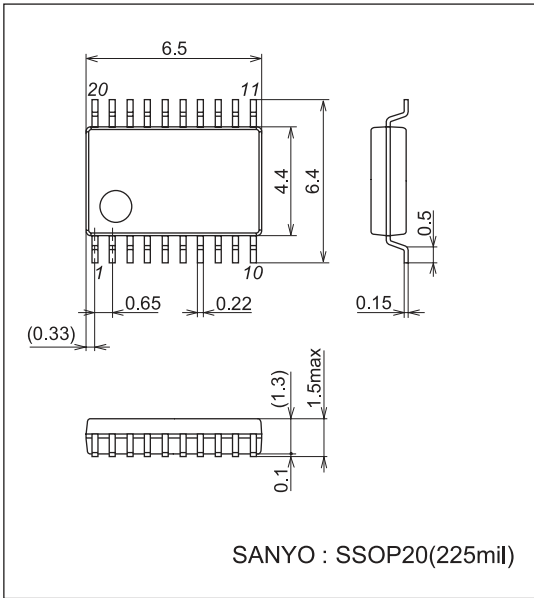

Package Dimensions

unit : mm (typ)

3036C

[LA1193M]

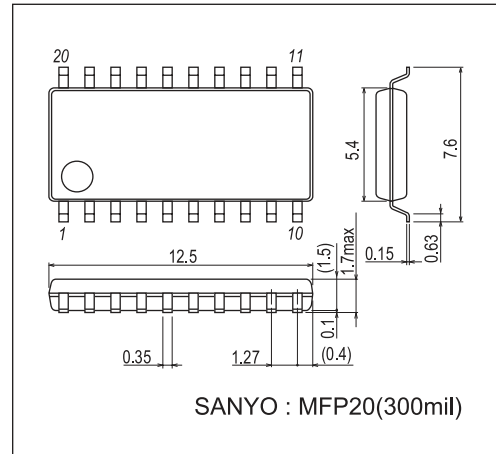

Block Diagram and Test Circuit Diagram

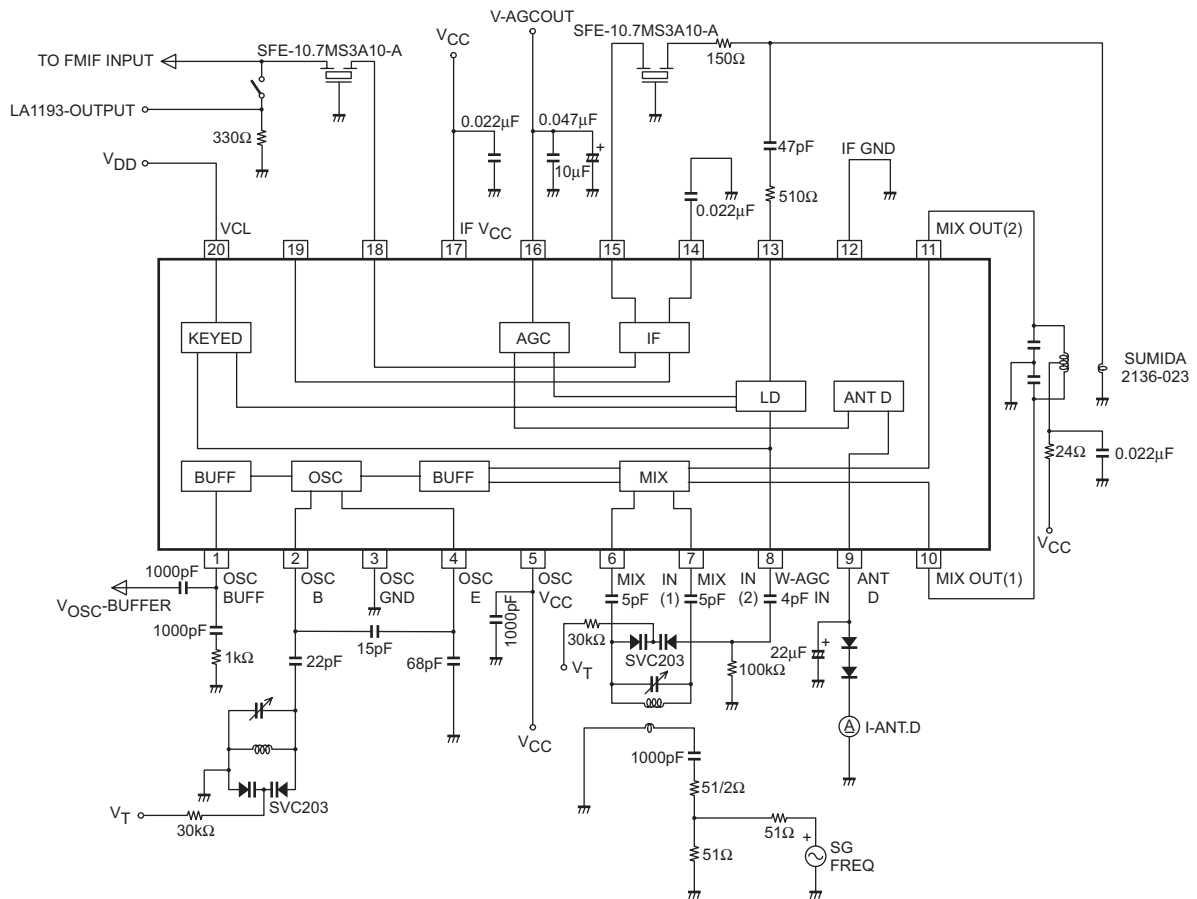

LA1193M, 1193V

Application Circuit Example : USA and Europe

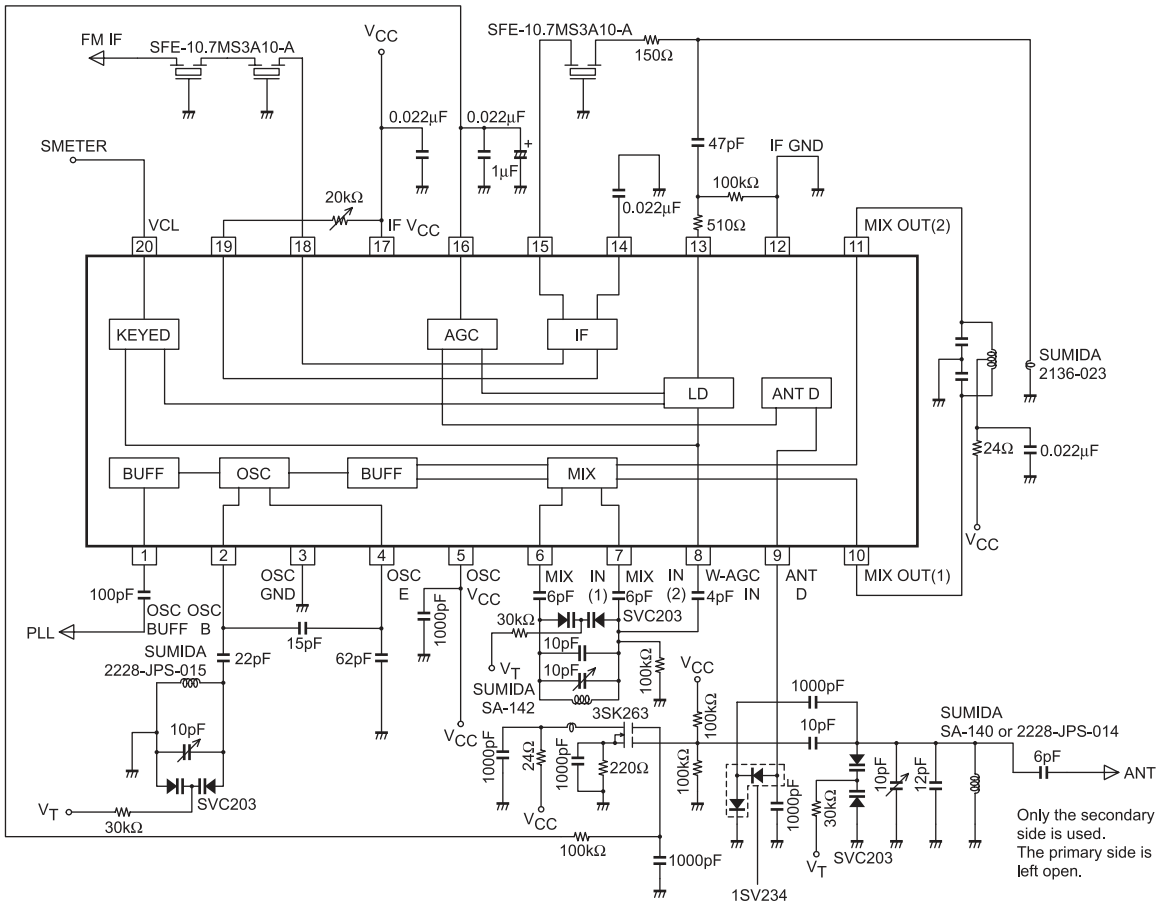

Application Circuit Example : Japan

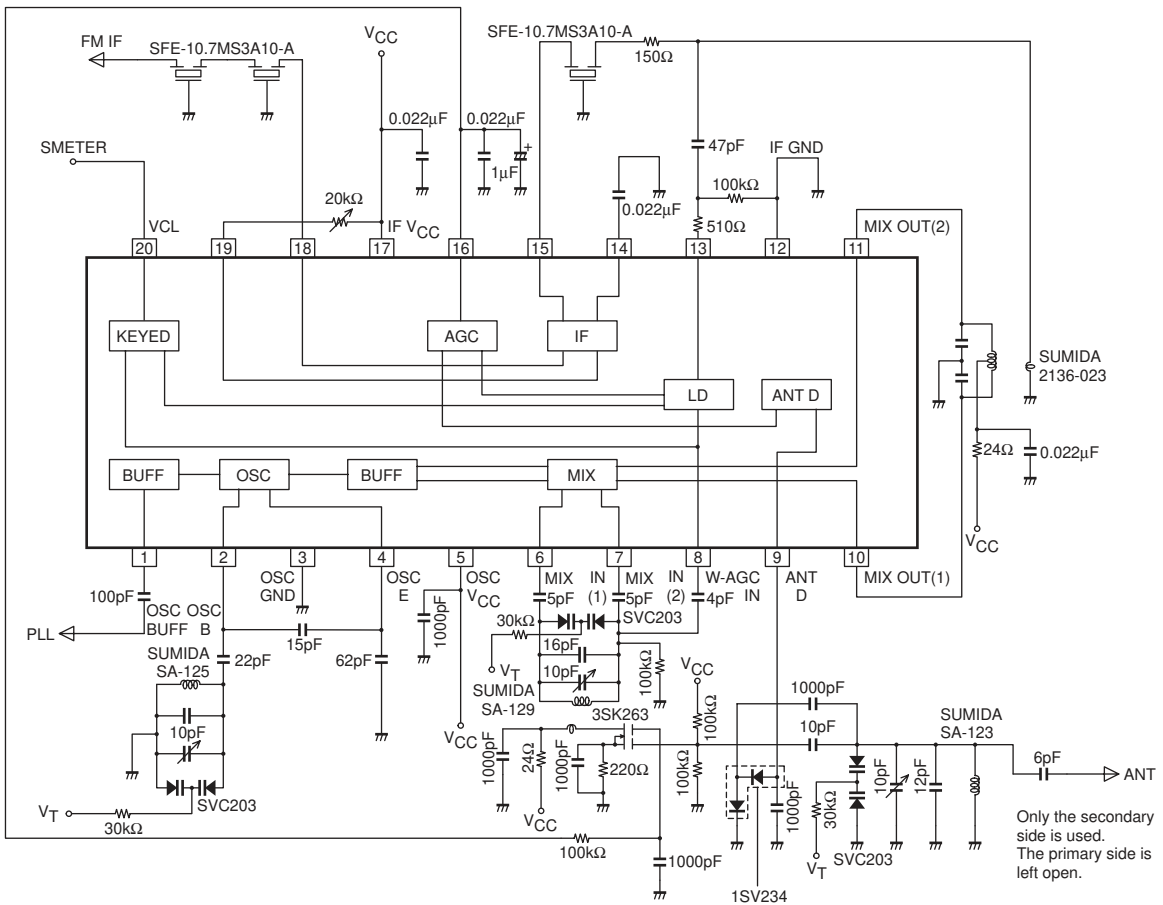

Coil Specifications

Coils Manufactured by Sumida Electronics

Japan band RF coil SA-129 or SA-143

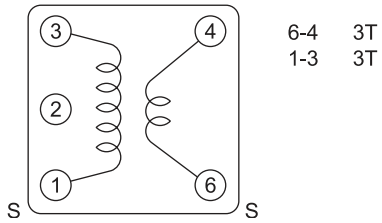

Japan oscillator coil SA-125

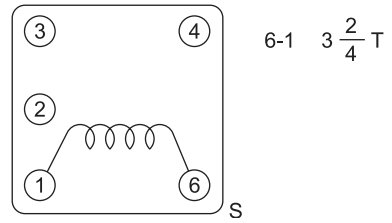

Japan antenna coil SA-123 or SA-144

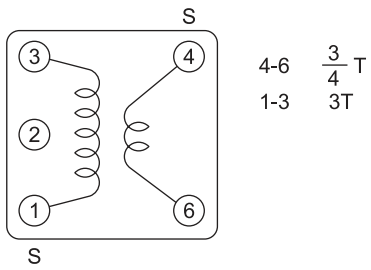

US band RF coil SA-142 or SA-250

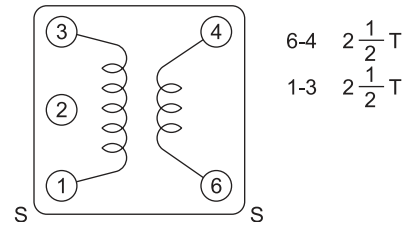

US band antenna coil SA-140 or SA-231

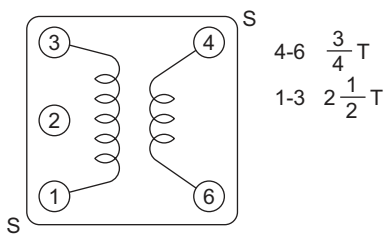

US band oscillator coil SA-278

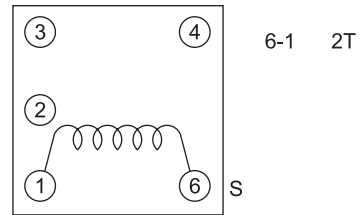

Mixer coil (for both bands) SA-266

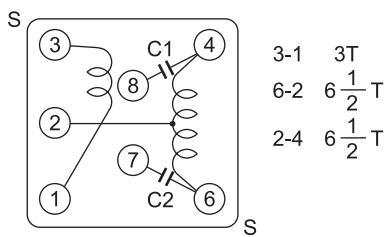

LA1193M, 1193V

Pin Functions

| Pin No. | Function | Equivalent circuit | Note |
|---------|------------------------------|--------------------|---------------------|
| 1 | OSC BUFF | | |
| 2 | OSC Tr. base | | Colpitts oscillator |
| 3 | OSC GND | | |
| 4 | OSC Tr. emitter | | |
| 5 | OSC VCC | | |
| 6 | Mix input (1) | | |
| 7 | Mix input (2) | | |
| 10 | Mix out (1) | | |
| 11 | Mix out (2) | | |
| 12 | IF GND | | |
| 9 | Antenna damping drive output | | IANTD = 10mA |
| 12 | IF GND | | |

Continued on next page.

LA1193M, 1193V

Continued from preceding page.

| Pin No. | Function | Equivalent circuit | Note |
|---------|--------------------|--------------------|--|
| 8 | W-AGC input | | Since the DC cut capacitor is provided on-chip in the pin internal circuit, we have taken steps to prevent incorrect AGC operation due to inter-pin leakage currents. |
| 13 | N-AGC input | | Since the DC cut capacitor is provided on-chip in the pin internal circuit, we have taken steps to prevent incorrect AGC operation due to inter-pin leakage currents. |
| 14 | IF AMP bypass | | IF gain : 25dB Input and output impedances of 330Ω The IF gain can be adjusted by inserting a resistor between pins 17 and 19. The gain is at its maximum when there is no resistor inserted. |
| 15 | IF AMP input | | |
| 18 | IF AMP output | | |
| 19 | IF AMP gain adjust | | |
| 16 | RF AGC OUTPUT | | MOSFET Second gate control |

Continued on next page.

LA1193M, 1193V

Continued from preceding page.

| Pin No. | Function | Equivalent circuit | Note |
|---------|-------------------|--------------------|--------------------------|
| 17 | IF, AGC, V_{CC} | | |
| 20 | Keyed AGC input | | Controls the narrow AGC. |

1. Oscillator Circuit

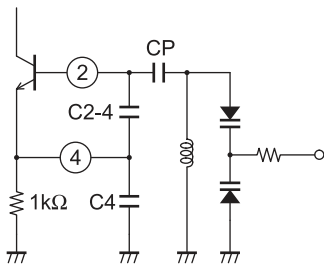

Steps were taken to prevent AMR degradation during earlier product type AGC operation, since the local oscillator block in this IC has independent V_d (pin 5) and ground (pin 3) connections.

This is a Colpitts oscillator and has the same structure as that used in earlier circuits. The oscillation level and intensity are changed by capacitors C_{2-4} , C_4 and C_p .

2. Local Oscillator Buffer Output

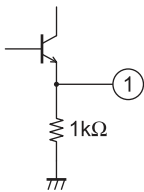

This buffer is an emitter follower circuit.

If desired, the buffer efficiency can be increased by inserting a resistor between pin 1 and ground to pass more current through the buffer transistor. However, this current must be limited so that P_{dmax} for the package is not exceeded.

LA1193M, 1193V

3. Interference Characteristics

The LA1193M incorporates a newly developed 3D-AGC (triple dimension) circuit. This circuit allows three-signal interference characteristics (inter-modulation characteristics) and two-signal sensitivity suppression characteristics to be provided at the same time, a combination of characteristics previously thought difficult to achieve.

• Inter-Modulation Characteristics

The LA1193M prevents inter-modulation distortion by applying two wide-band AGC circuits.

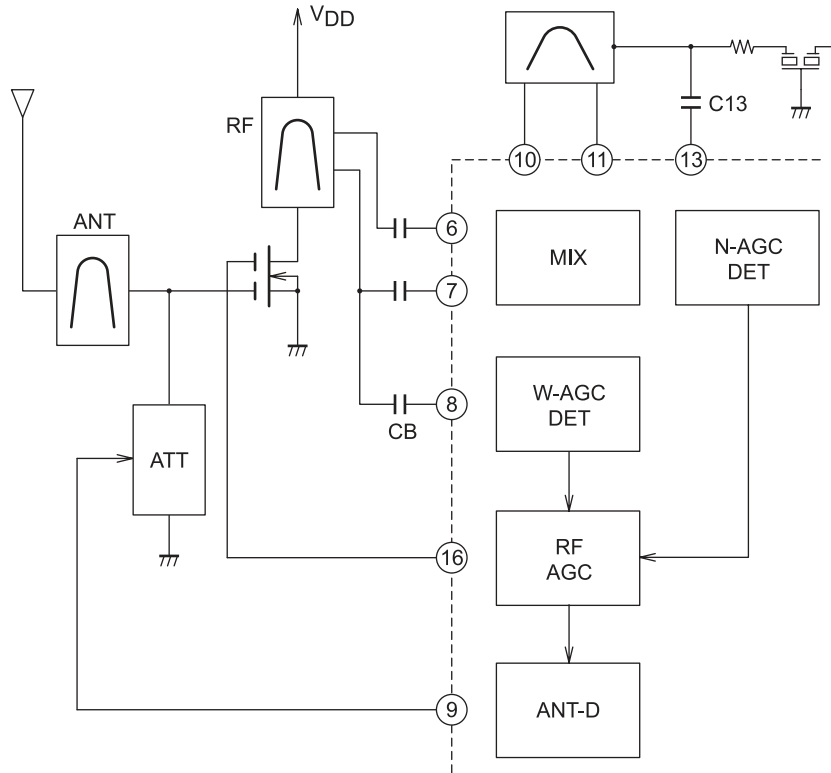

Figure 1

This double wide-band AGC system consists of two AGC circuits and a narrow AGC (pin 13 input, mixer input detection type) as shown in Figure 1. Figure 2 shows the antenna input frequency characteristics.

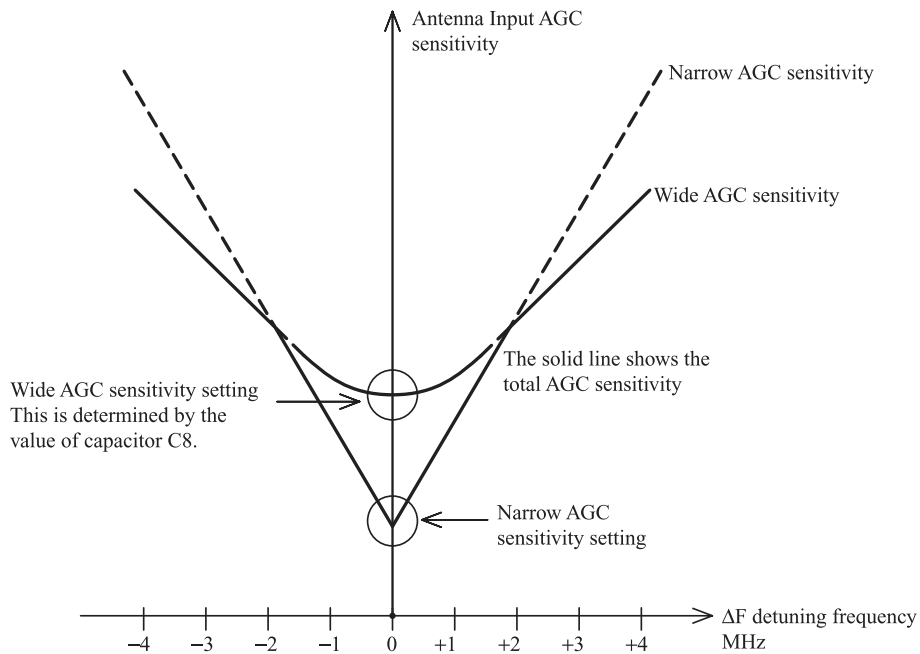

Figure 2 AGC Sensitivity Detuning Characteristics

LA1193M, 1193V

Features of the Double Wide AGC System

- Since this is a mixer input detection wide-band AGC, it prevents the occurrence of intermodulation due to interfering stations with $\Delta f > 1\text{MHz}$. (TV band interference prevention)
- Since this system uses a narrow AGC at the same time, the wide AGC sensitivity can be lowered, thus preventing incorrect operation due to local oscillator injection.
- Optimal sensitivities for any field conditions can be set, since the sensitivities of both the wide and narrow AGC systems can be set by changing the values of external components.
- The input level of the desired station is limited by the narrow AGC. As a result, excessive levels are no longer input to the stages that follow the mixer and the beats at multiples of $10.7 \times A$ are reduced.

• Two-Signal Sensitivity Suppression Characteristics

Previously, keyed AGC systems were used to provide good intermodulation distortion and two signal sensitivity suppression characteristics at the same time. However, in previous keyed AGC systems, when the desired station would fade or drop out, the wide band AGC level would become essentially zero. As a result, the automatic station selection function would malfunction and blocking oscillation would occur in the presence of strong interfering stations. Thus keyed AGC systems were extremely hard to use in actual practice. Sanyo has developed a new AGC system (3D-AGC) that solves these problems and allows the construction of extremely simple application circuits. The LA1193M/V incorporates this AGC system.

What is the 3D-AGC system?

It is a system that determines the wide-band AGC level by using information that has the following three frequency characteristics.

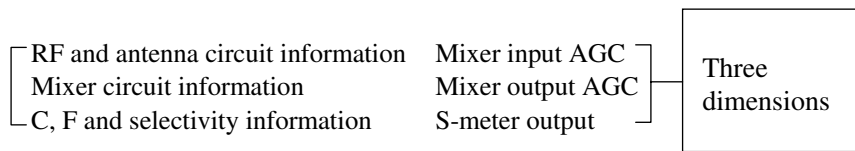

3D-AGC Features

| Feature | Merit |
|--|---|
| The narrow AGC sensitivity, which operates for Δf of less than 1.5MHz, is controlled independently according to the field strength of the desired station. | <ul style="list-style-type: none"> • This is effective as a measure for mitigating two signal sensitivity suppression. |
| The narrow AGC sensitivity is controlled at V_{20} values under 2V. | <ul style="list-style-type: none"> • This allows two signal sensitivity suppression to be mitigated without deterioration in the three signal characteristics. |
| The wide AGC operates even when V_{20} is zero, i.e., when the desired station does not exist. | <ul style="list-style-type: none"> • This allows the prevention of incorrect stopping on intermodulation signals during search. • This allows the prevention of intermodulation occurring in the antenna and RF modulation circuits in the presence of strong interfering stations. Prevention of blocking oscillation due to AGC operation is also possible. |
| The N-AGC and the W-AGC sensitivities can be set independently. | <ul style="list-style-type: none"> • This allows optimal settings to match the reception field conditions. |
| The system has two AGC systems, the N-AGC and the W-AGC. | <ul style="list-style-type: none"> • Since the narrow AGC operates at the desired station and at adjacent stations, it is possible to reduce the wide AGC sensitivity. This prevents incorrect AGC operation due to local oscillator injection. |

3D-AGC Sensitivity, Δf and V_{20} Characteristics

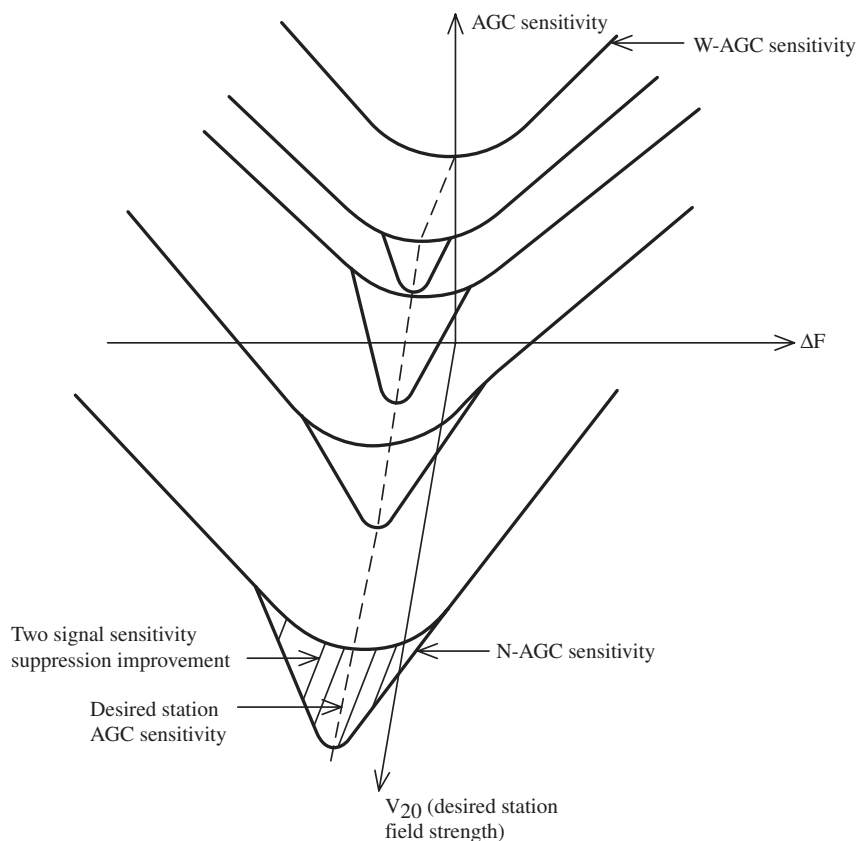

Figure 3 3D-AGC Sensitivity, Δf and V_{20} Characteristics

- The W-AGC sensitivity is determined by the antenna RF circuit selectivity independently of V_{20} .
- The N-AGC sensitivity is determined by the antenna, RF and mixer circuit total selectivity when V_{20} is 0.6V or greater. It is determined by that selectivity and V_{20} when V_{20} is over 0.6V.
- The improvement in two-signal sensitivity suppression is the shaded area in the total AGC sensitivity and corresponds to the section occupied by the N-AGC.

4. Mixer

The mixer circuit used in this IC is a balanced input/balanced output double balance mixer circuit.

• Input Format

Emitter input
Input impedance : 25Ω

Optimization of the component geometry, emitter current and bias allow this circuit to achieve the following performance.

Mixer input usable sensitivity : $15\text{dB}\mu$
Mixer input IMQS* : $90.5\text{dB}\mu$

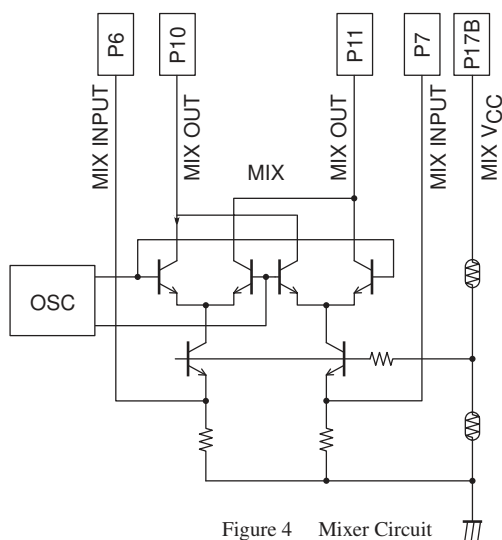

Figure 4 Mixer Circuit
(Improved by $6.0\text{dB}\mu$ over previous products.)

Note : *Mixer input IMQS is defined as follows :

$f_r = 98.8\text{MHz}$, no input
 $f_{u1} = 98.8\text{MHz}$, 1kHz , 30% modulation
 $f_{u2} = 99.6\text{MHz}$, no modulation

IMQS is the interference 1 and 2 input levels such that when an interference signal with the same level is input to the mixer and distortion occurs at the mixer, the generated IM output has a S/N ratio of 30dB .

5. IF Amplifier

This IF amplifier is a single stage differential amplifier.

Specifications

Input impedance : 330Ω
 Output impedance : 330Ω
 Gain : 25dB

Gain adjustment can be provided using either of the methods shown.

IF Gain adj

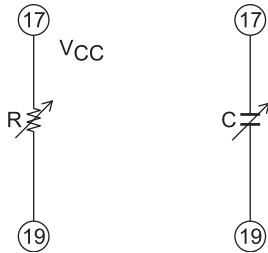

Temperature Characteristics

The LA1193M/V uses Vref temperature characteristics correction to hold the gain temperature characteristics to the low level of about 1dB over the range -30 to +80°C.

6. AGC Circuit

The LA1193M/V uses pin diode antenna damping (pin 9) and MOSFET second gate voltage control (pin 16) for AGC. The AGC operating sequence is as follows :

Antenna damping (pin diode) → MOSFET second gate voltage control
 (attenuation) 20dB (attenuation) dB

The above AGC sequence is used for the following reasons.

- Intermodulation distortion can occur if a signal of 110dBμ or larger is input to the antenna circuit varactor diode. In such situations, if the AGC sequence was MOSFET second gate voltage control followed by pin diode antenna damping, as long as the receiver was not in a strong field where the 60dB or higher AGC attenuation operates, input limitation due to the antenna circuit varactor diode would operate. Therefore, we feel that the AGC operating sequence employed is appropriate.
- Consider the problem of AGC loop stability. If the two AGC loops (the antenna damping AGC loop and the MOSFET second gate control AGC loop) operate, the AGC system would become unstable and have an excessively large influence on the transient response. Therefore the following structure cannot be used.
 MOSFET second gate control → antenna damping → MOSFET second gate control
 The AGC operating conditions are the same as those for the LA1175M.
- Narrow AGC circuit
 Since the LA1193M/V's N-AGC (which detects the mixer output) is set to have a high sensitivity, care is required to avoid incorrect operation. In particular, there must be adequate separation from the local oscillator block on the printed circuit board pattern. Also, a resistor of at least 500Ω must be inserted at the pin 13 input. A low-pass filter is formed by the insertion of this resistor. This low-pass filter prevents incorrect AGC operation due to the local oscillator.
- The AGC sensitivity setting can be changed by adjusting the value of the capacitor connected at pin 13. Although the AGC sensitivity can be lowered by increasing the value of the series resistor, caution is required since the AGC has its own frequency characteristics.

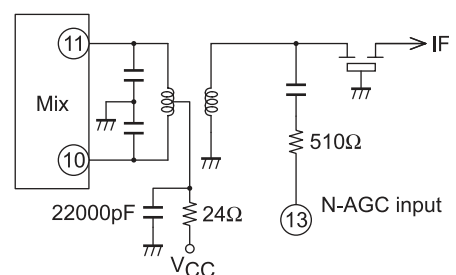
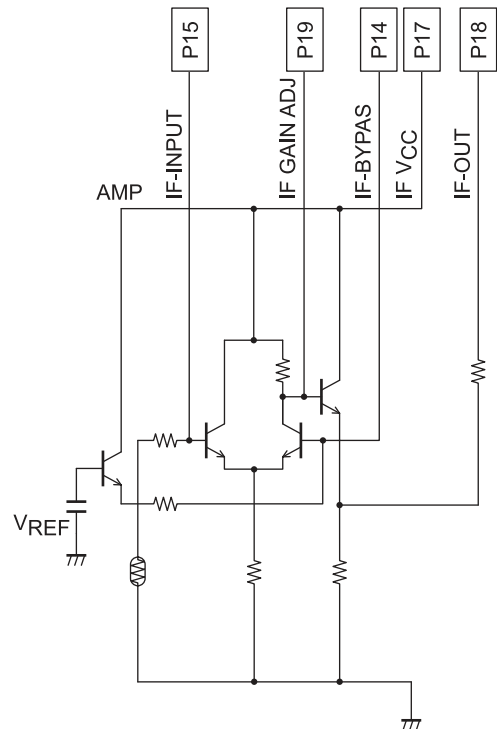

LA1193M, 1193V

- Wide AGC circuit

The wide AGC sensitivity is set by the value of the capacitor on pin 8. However, since incorrect operation due to the local oscillator signal may occur if this capacitor is too large, its value must be chosen carefully.

- 3D-AGC

If the difference in sensitivity between the N-AGC and the W-AGC systems is too large during 3D-AGC operation, the S/N ratio can be degraded in the vicinity of the input where the AGC switches. Therefore, the 3D-AGC setting values must be selected carefully. Although this problem can be ameliorated by applying a time constant to pin 20, in principle, this S/N ratio degradation should be prevented by limiting the sensitivity difference between the two AGC systems.

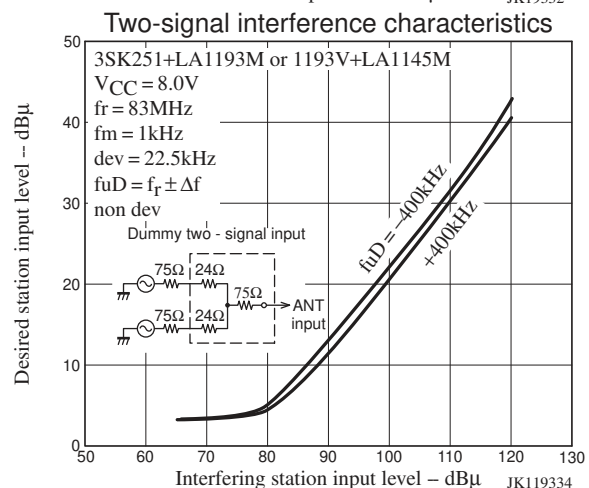
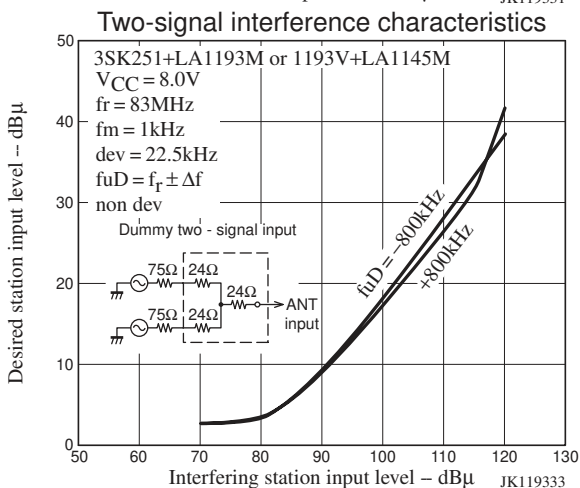
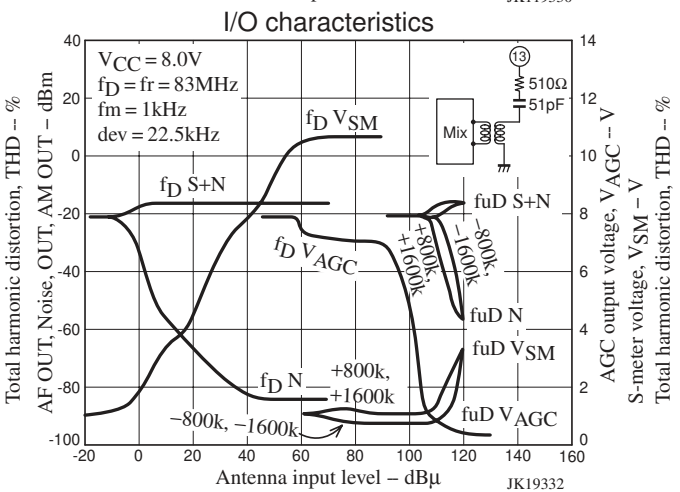
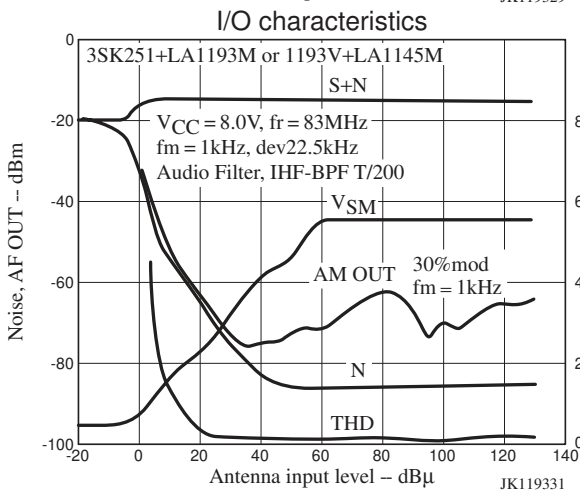
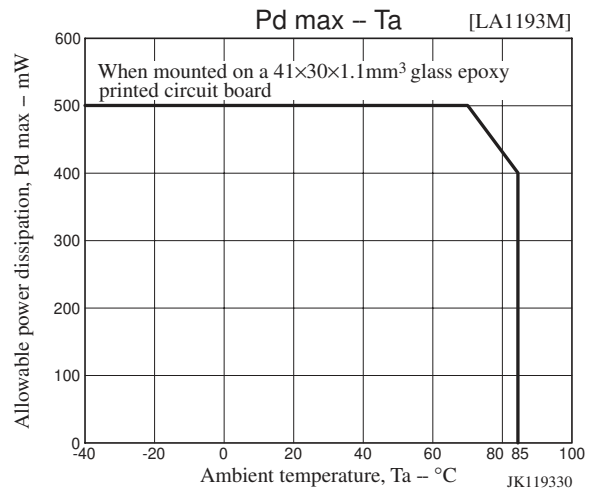
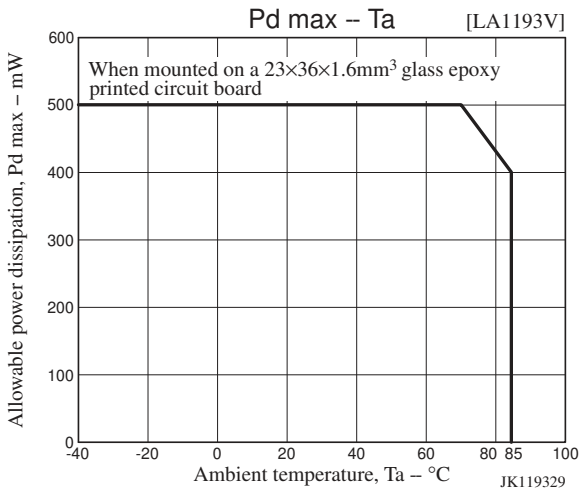

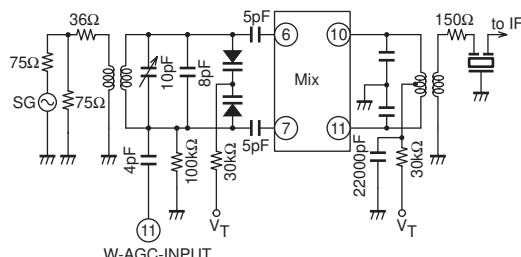
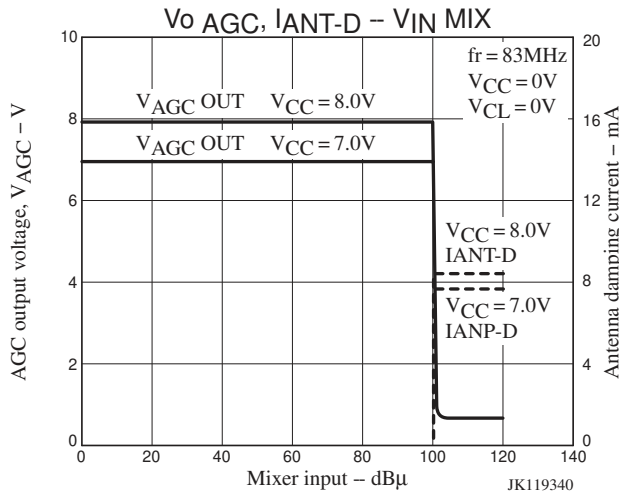
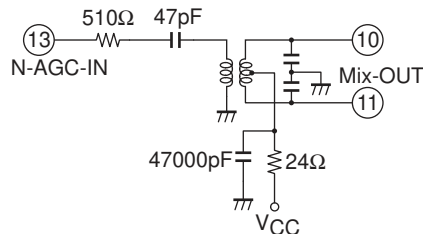
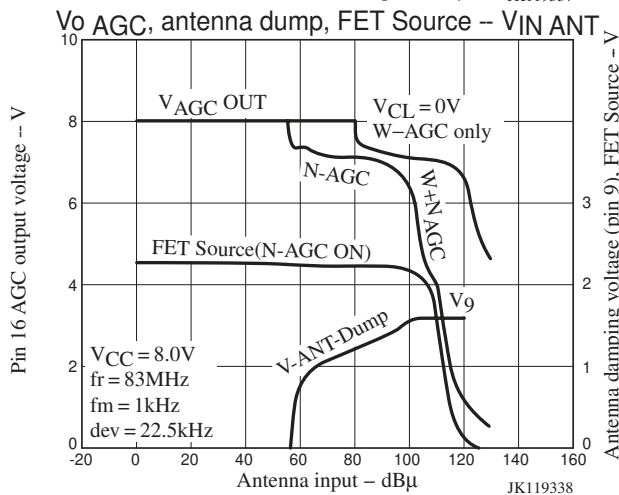
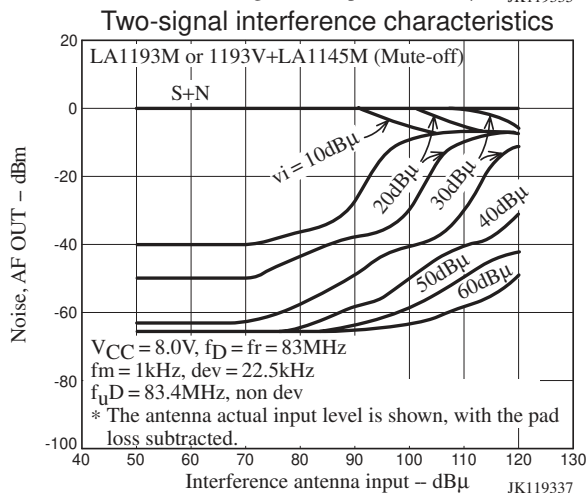
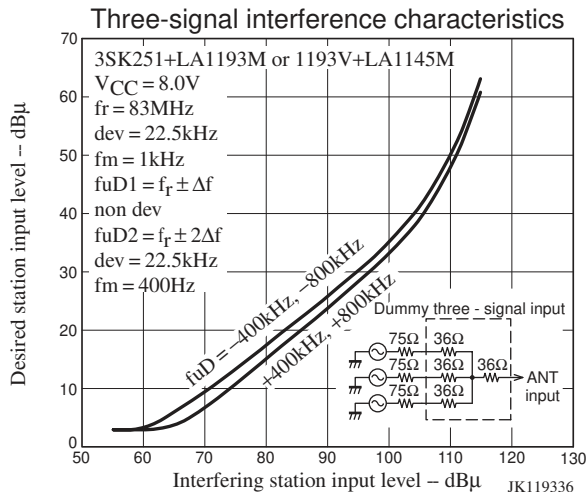
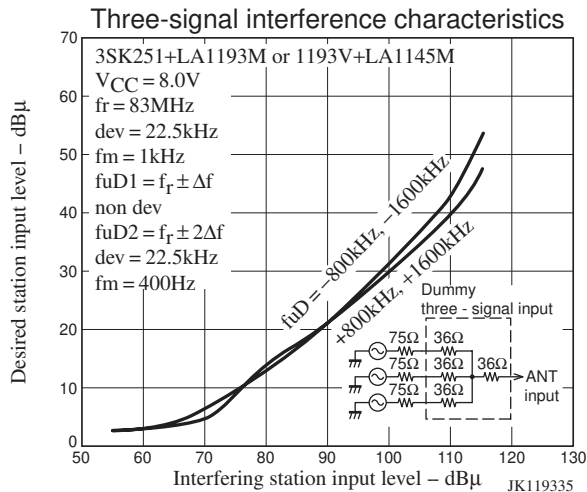

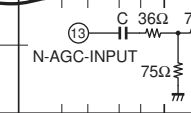
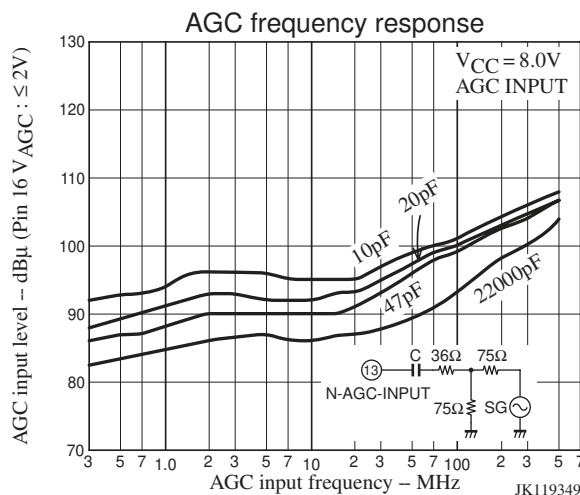
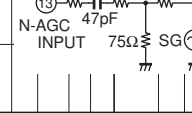
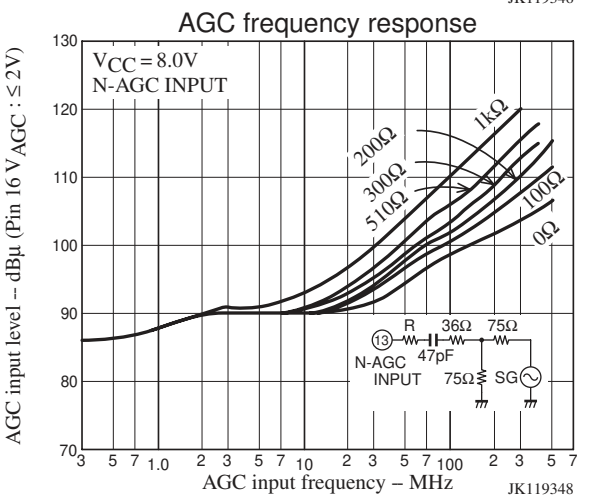
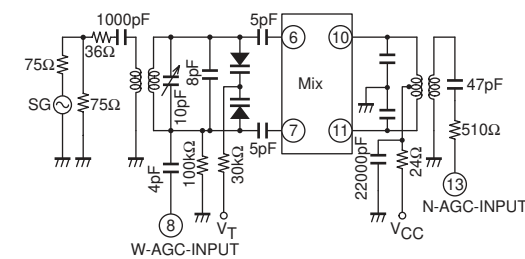
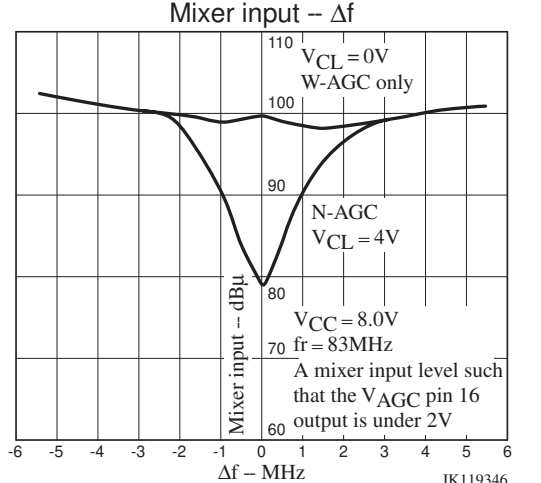
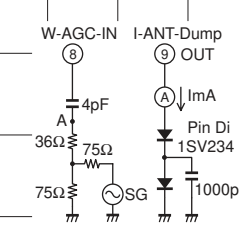
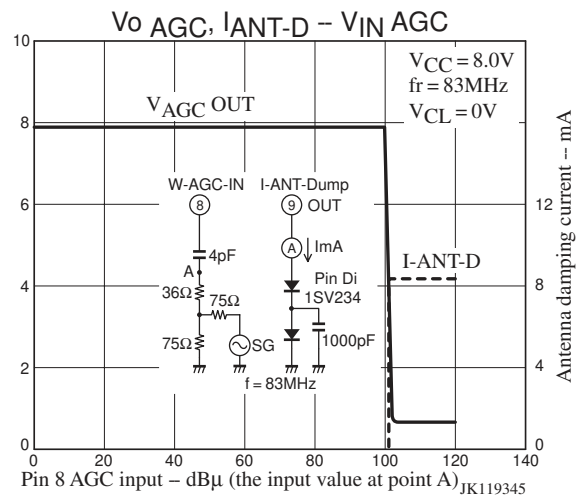
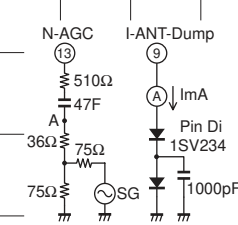
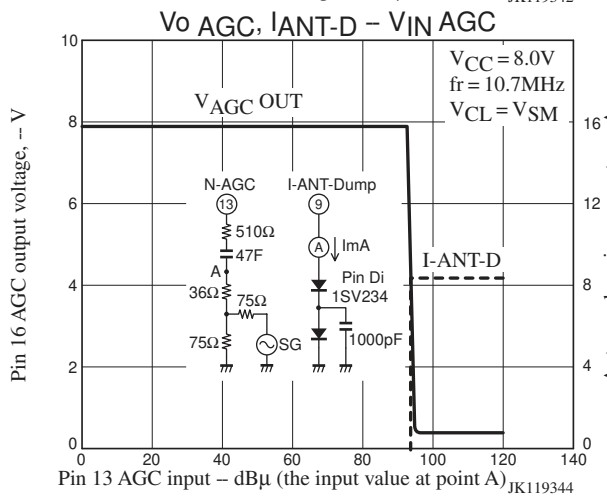
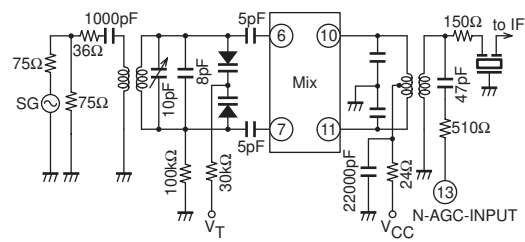
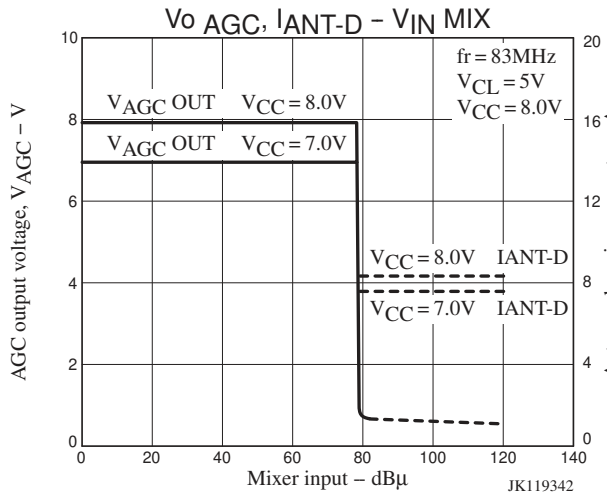

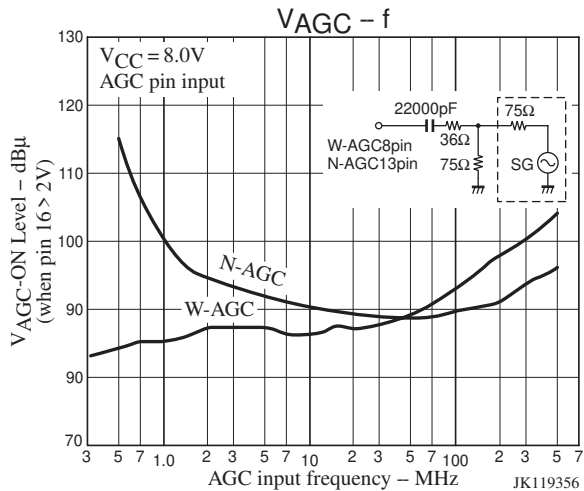
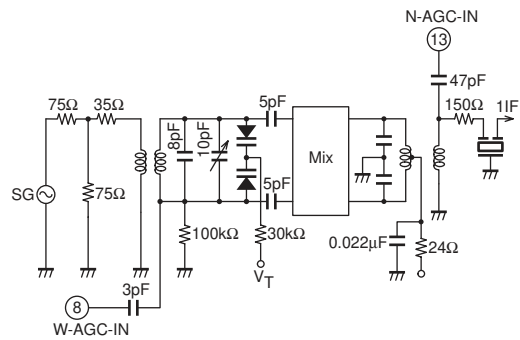
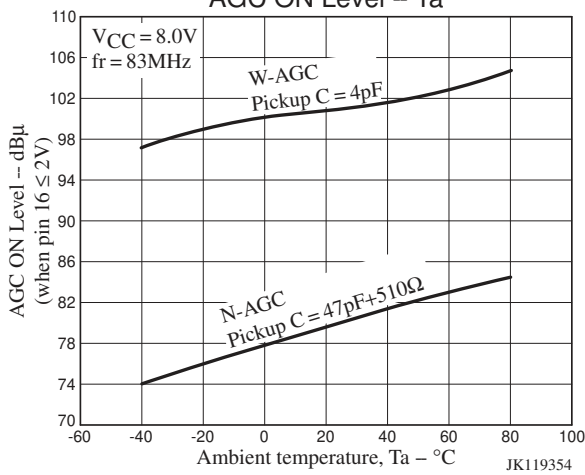
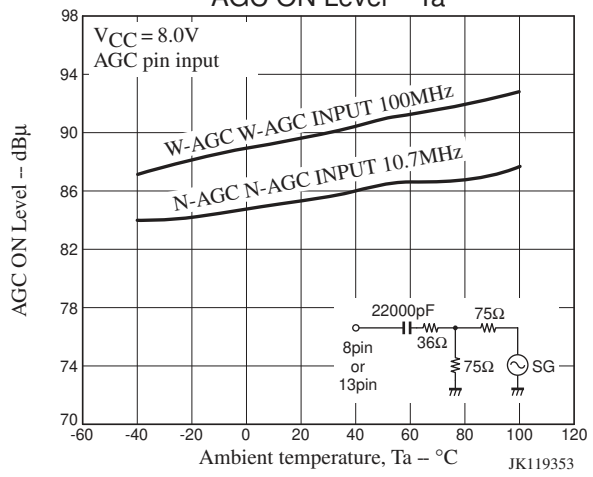
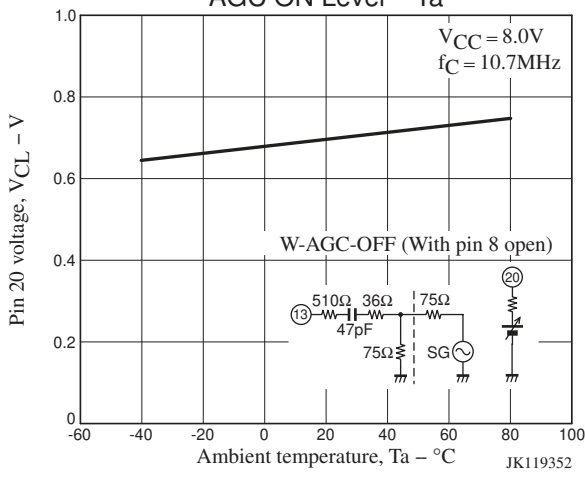
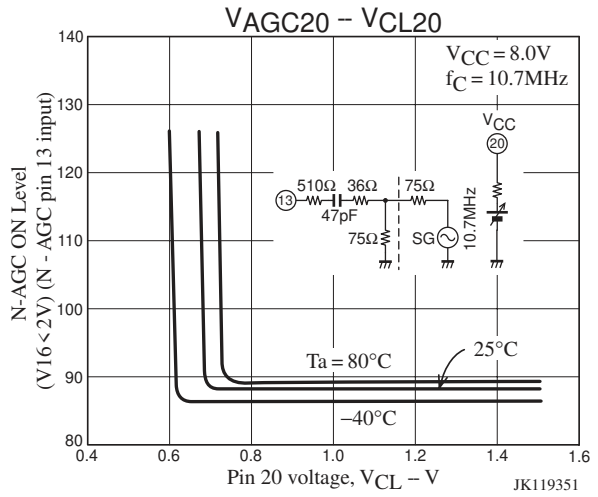
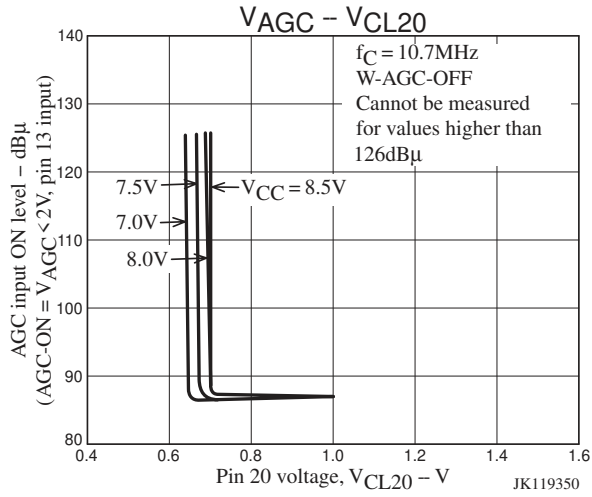

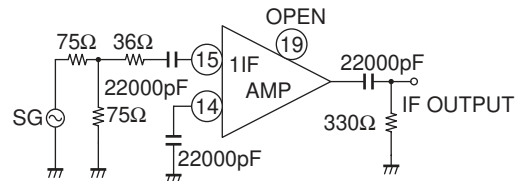
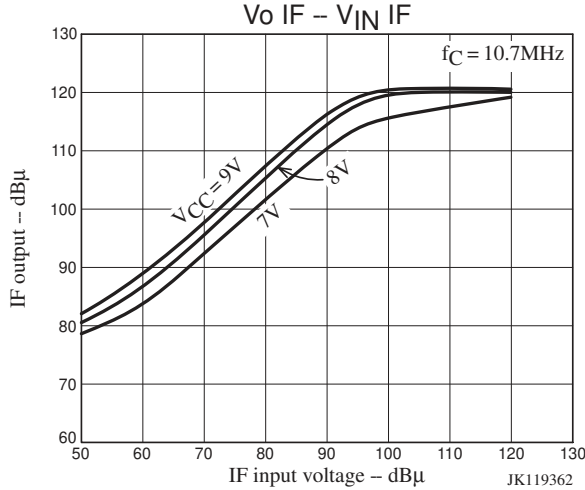
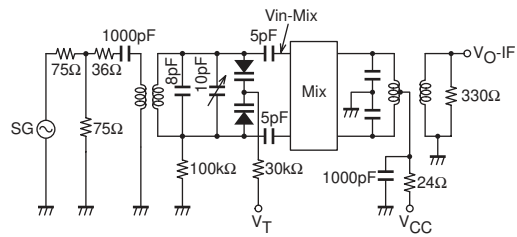
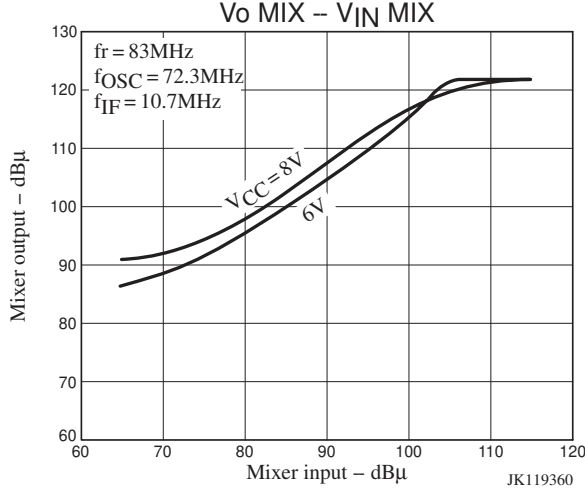
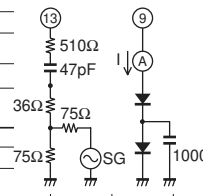
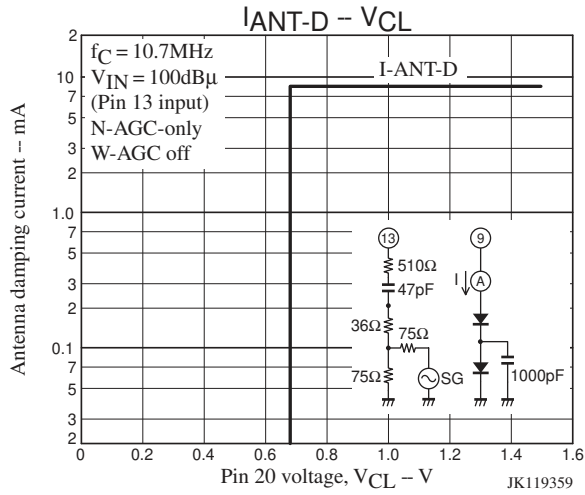
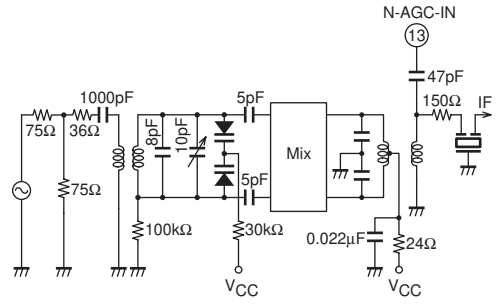
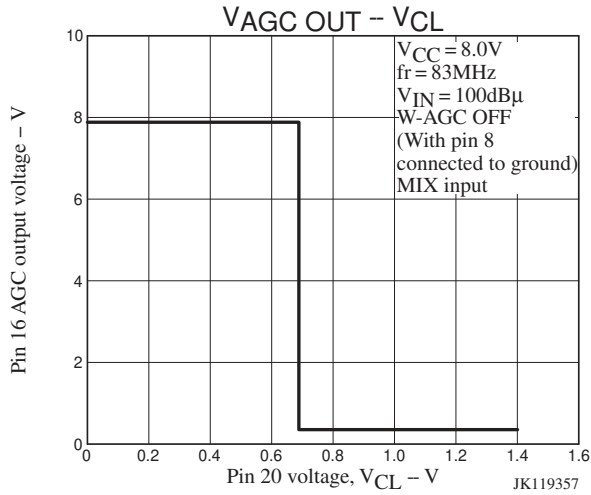

LA1193M, 1193V

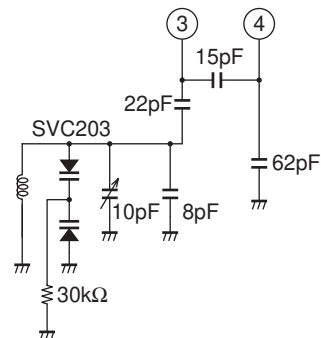
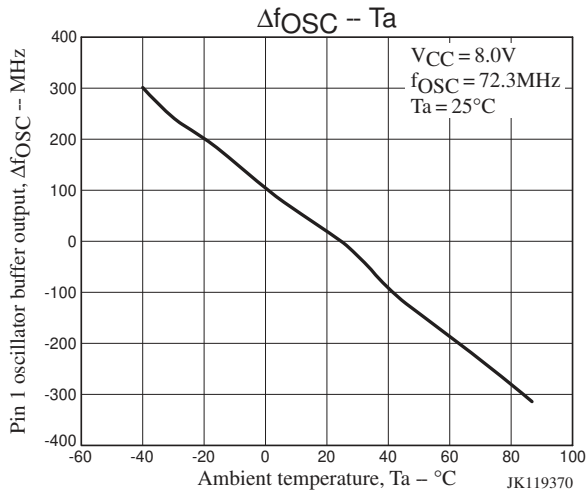
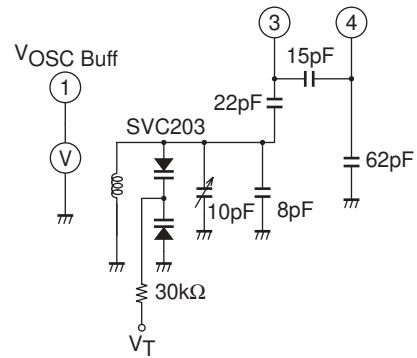
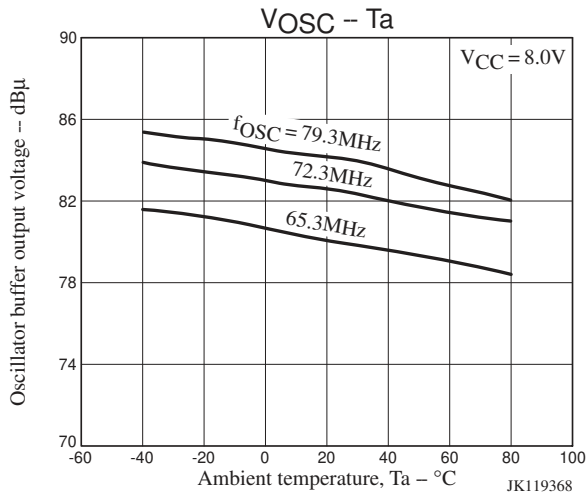
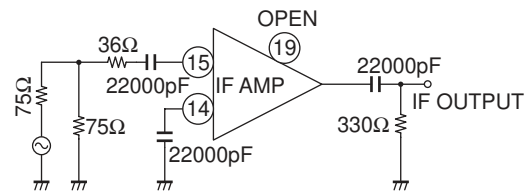
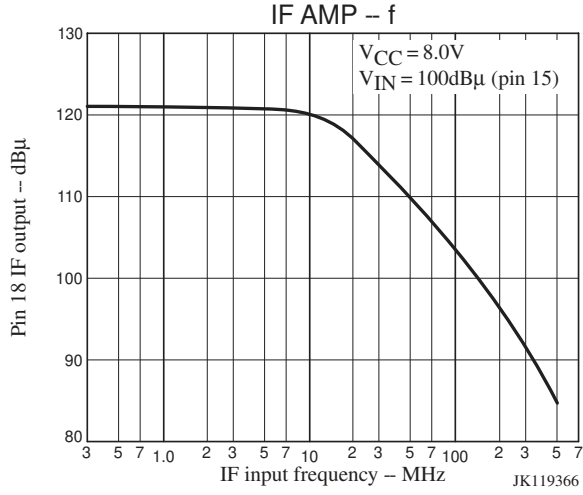
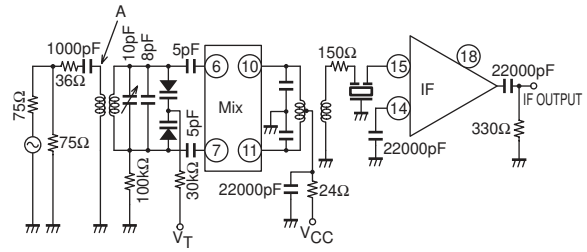
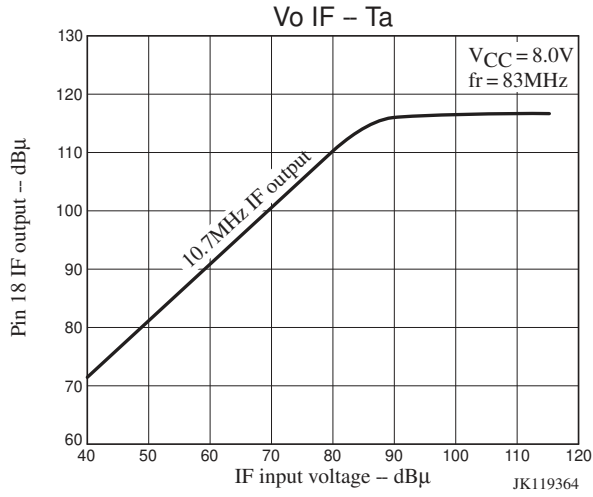

LA1193M, 1193V

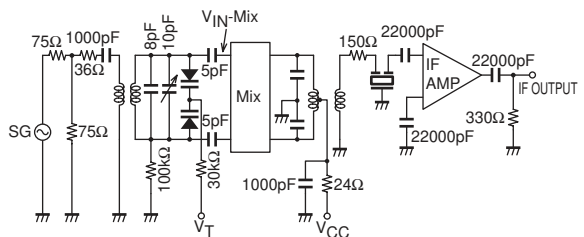
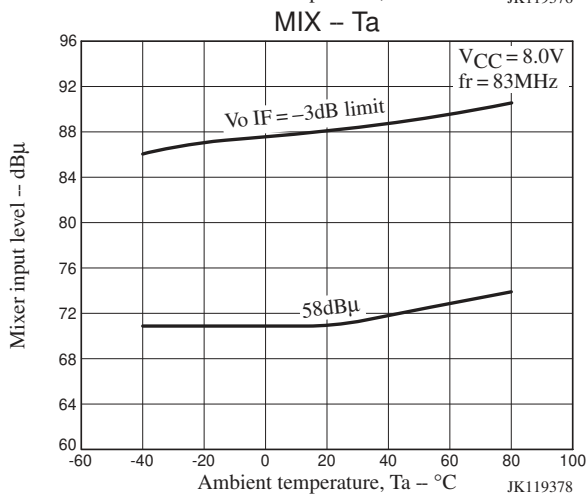
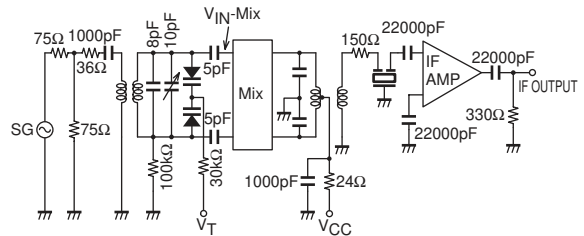
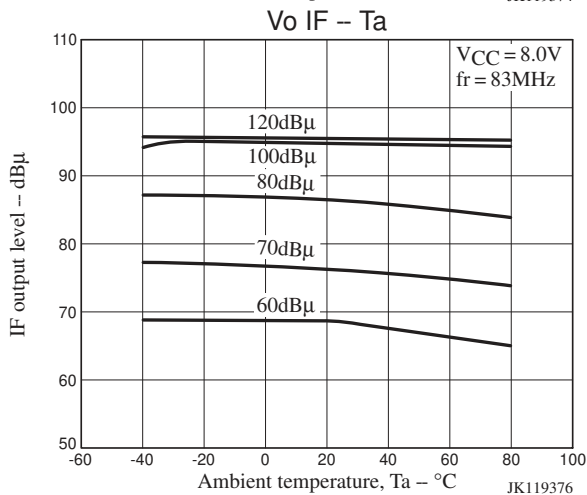
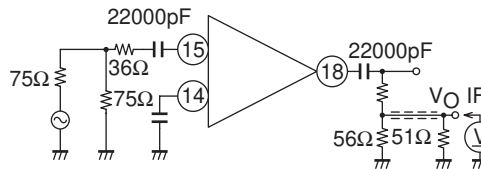
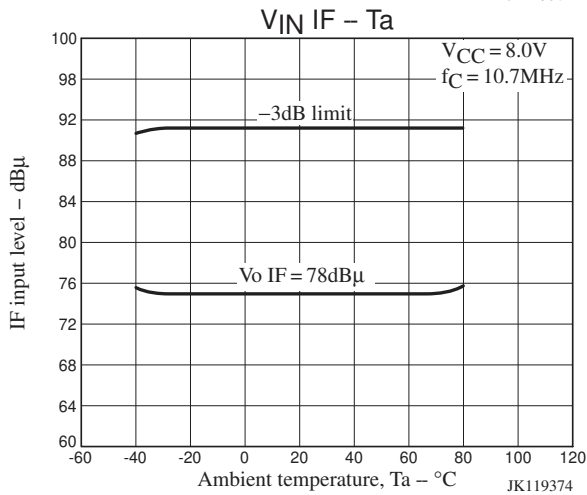
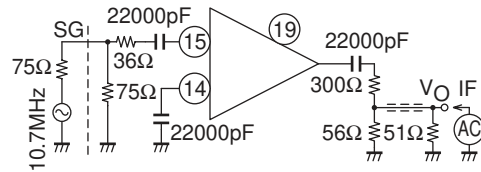
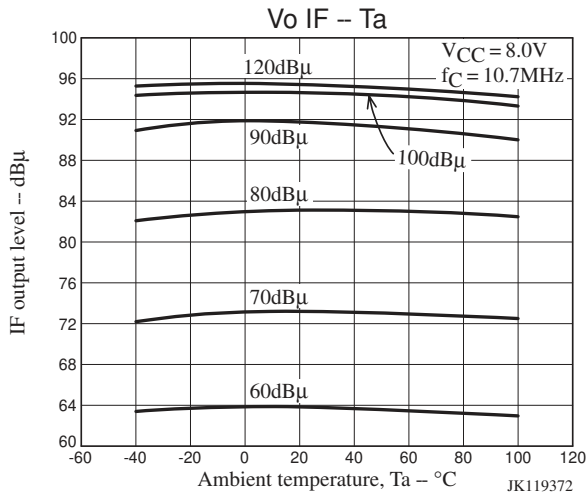

LA1193M, 1193V

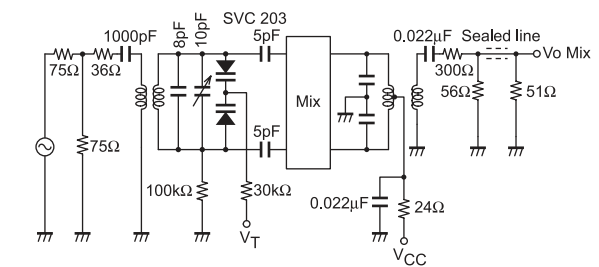
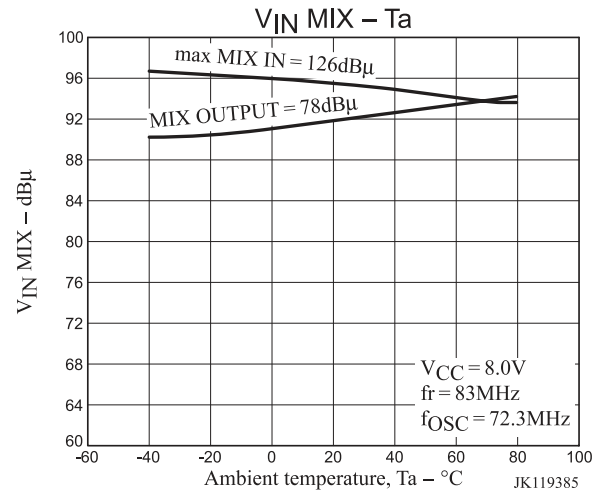
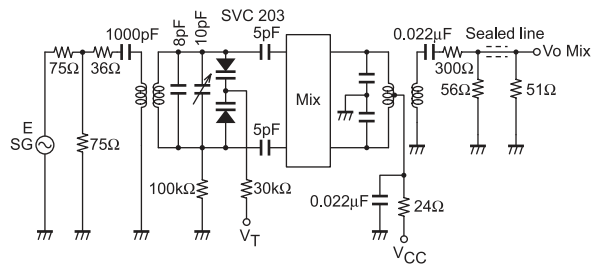
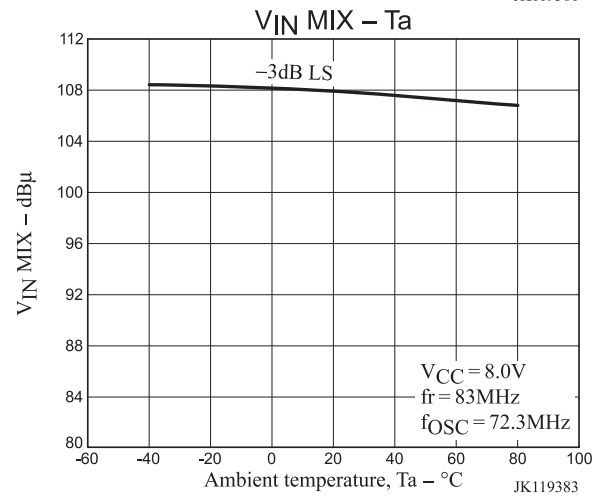
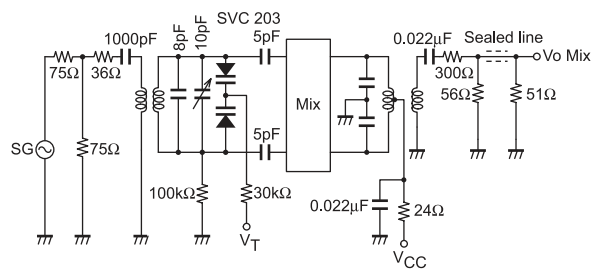
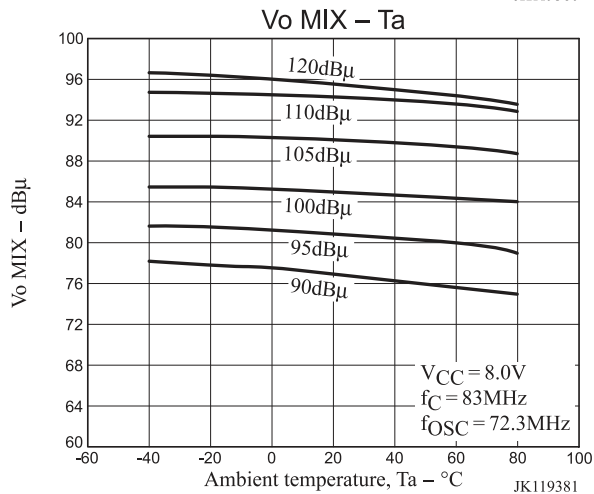
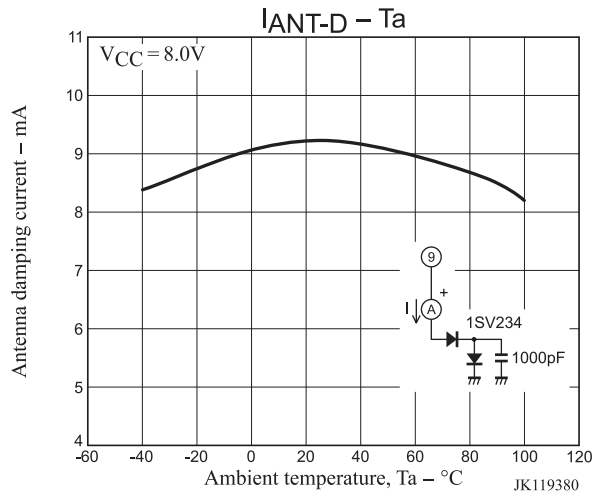

LA1193M, 1193V

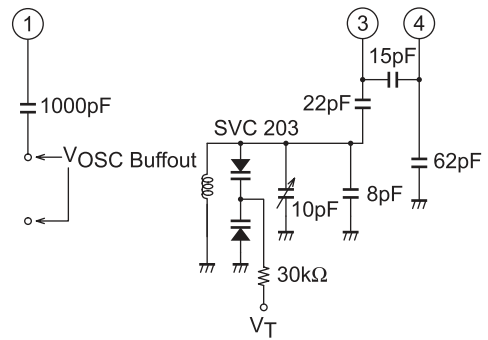
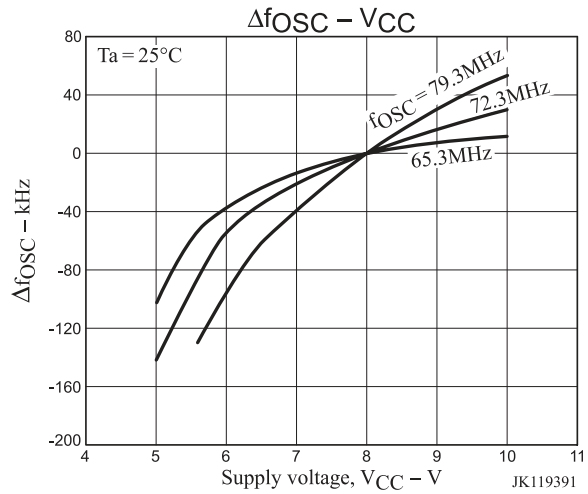
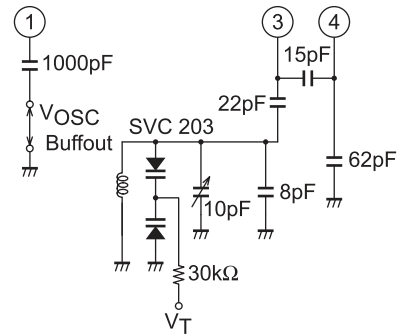
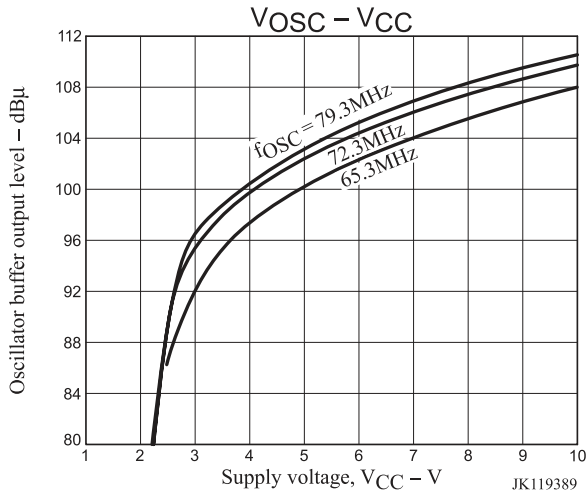
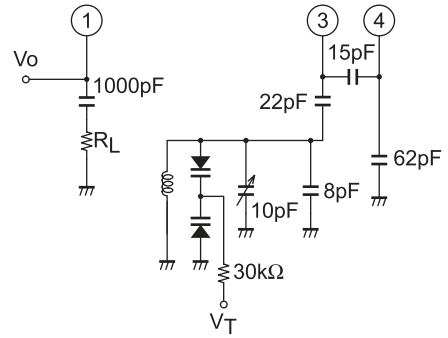
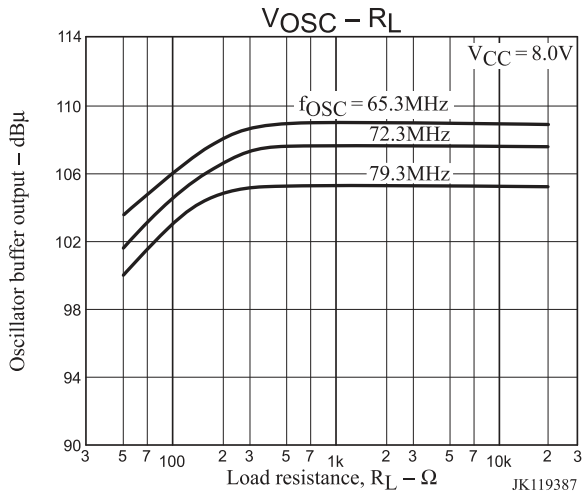

- SANYO Semiconductor Co.,Ltd. assumes no responsibility for equipment failures that result from using products at values that exceed, even momentarily, rated values (such as maximum ratings, operating condition ranges, or other parameters) listed in products specifications of any and all SANYO Semiconductor Co.,Ltd. products described or contained herein.
- SANYO Semiconductor Co.,Ltd. strives to supply high-quality high-reliability products, however, any and all semiconductor products fail or malfunction with some probability. It is possible that these probabilistic failures or malfunction could give rise to accidents or events that could endanger human lives, trouble that could give rise to smoke or fire, or accidents that could cause damage to other property. When designing equipment, adopt safety measures so that these kinds of accidents or events cannot occur. Such measures include but are not limited to protective circuits and error prevention circuits for safe design, redundant design, and structural design.
- In the event that any or all SANYO Semiconductor Co.,Ltd. products described or contained herein are controlled under any of applicable local export control laws and regulations, such products may require the export license from the authorities concerned in accordance with the above law.
- No part of this publication may be reproduced or transmitted in any form or by any means, electronic or mechanical, including photocopying and recording, or any information storage or retrieval system, or otherwise, without the prior written consent of SANYO Semiconductor Co.,Ltd.
- Any and all information described or contained herein are subject to change without notice due to product/technology improvement, etc. When designing equipment, refer to the "Delivery Specification" for the SANYO Semiconductor Co.,Ltd. product that you intend to use.
- Information (including circuit diagrams and circuit parameters) herein is for example only; it is not guaranteed for volume production.
- Upon using the technical information or products described herein, neither warranty nor license shall be granted with regard to intellectual property rights or any other rights of SANYO Semiconductor Co.,Ltd. or any third party. SANYO Semiconductor Co.,Ltd. shall not be liable for any claim or suits with regard to a third party's intellectual property rights which has resulted from the use of the technical information and products mentioned above.

This catalog provides information as of May, 2008. Specifications and information herein are subject to change without notice.