

PART NUMBER	REV	FIRST USED
466907-2	P	463345-1
7-466907-7	N	

TERMINAL NAME:		CONTACT, TYPE III, V1 & X	
PIN	SOCKET		
66102	66104		
66192	66194		
66296	66297		
66583	66584		
164160	66662		
66645	163087		
66671	170247		
163085			
170245			

VISIBLE PAD LTR	CRIMPING DATA		
	CRIMP HEIGHT	WIRE SIZE	
A	.038 ±.002	22	
B	.036 ±.002	24	
C	.042 ±.002	20 Δ	
D	NOT	USED	
CRIMP	SIZE	TYPE	RANGE
WIRE	.062	F	24-22 Δ
INSUL	.090	0	.040-.080
FEED	APPL INST	SET UP GAGE	LAYOUT
.500	Δ I-	-	162
WIRE STRIP LENGTH			
-			

LOC	DIST	REVISIONS			
P	LTR	DESCRIPTION	DATE	OWN	APVD
A	66				
P		ECR-08-011943	5-2008	MY	GB

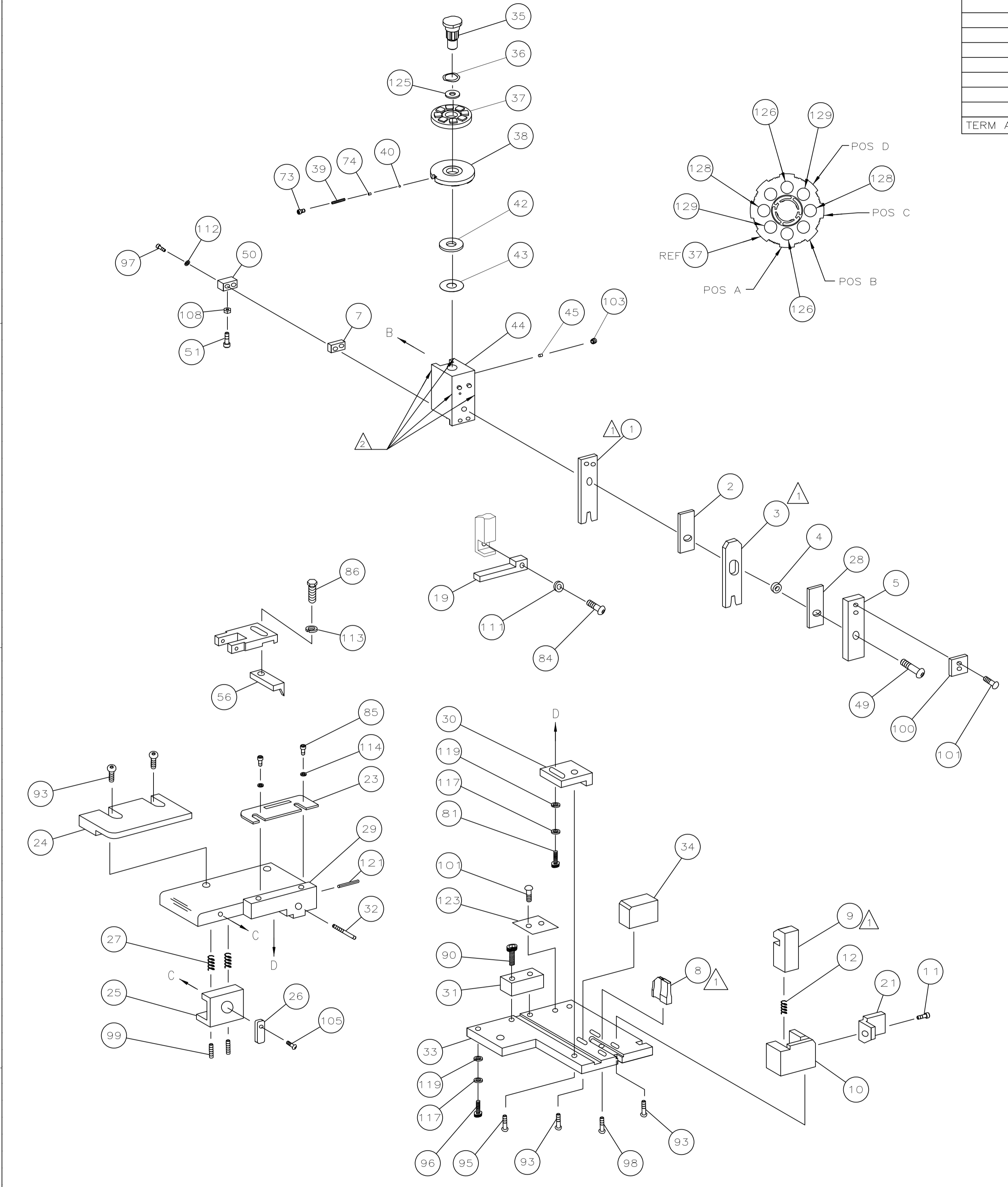

-	2	-	5-354779-8	PIN, WIRE DISC (.3280)D	129	
-	2	-	5-354779-4	PIN, WIRE DISC (.3260)C	128	
-	2	-	4-354779-5	PIN, WIRE DISC (.3215)A	126	
-	1	-	986950-1	WASHER, FLAT PRECISION	125	
-	1	-	690701-2	PLATE, SERIAL NO.	123	
-	1	-	4-21028-0	PIN,SLT SPR(ϕ .093x.75)ST GDE PL	121	
-	2	-	21899-2	WASHER,FLAT(#10)S G ADJ BLK	119	
-	2	-	21024-5	WASHER, LOCK(#10)ADJ BLOCK	117	
-	2	-	21024-2	WASHER,LOCK(#4)FRONT STP GUIDE	114	
-	REF	-	21024-4	WASHER,LOCK(#8)FEED FINGER	113	
-	2	-	21024-4	WASHER,LOCK(#8)DEP-HOLD	112	
-	REF	-	21024-4	WASHER,LOCK(#8)STRIPPER	111	
-	1	-	21018-5	NUT,HEX(#6)HOLD DOWN	108	
-	1	-	22353-8	SCR,SHLD(ϕ .187x.25)DRAG LEVER	105	
-	1	-	21009-2	SCR,SKT SET(1/4-20x.25 LW)RAM	103	
-	4	-	21017-2	SCR,DRIVE(#2x.19)ID PLATE	101	
-	1	-	819347-1	PLATE, IDENTIFICATION	100	
-	2	-	5-21006-6	SCR,SET(10-32x.75)DRAG	99	
-	1	-	22733-8	SCR,BHC(8-32x.38 LW)ANVIL	98	
-	2	-	3-21000-0	SCR,SHC(8-32x.88)DEP HOLD	97	
-	1	-	3-21000-8	SCR,SHC(10-32x.88)MOUNTING	96	
-	1	-	2-21002-7	SCR,BHC,(10-32x.50)SG ADJ BLK	95	
-	-	-	-	-	94	
-	6	-	2-21002-2	SCR,BHC(8-32x.50)R STP GDE	93	
-	1	-	1-21002-7	SCR,SHC(6-32x.50)CAM	91	
-	2	-	2-21000-7	SCR,SHC(8-32x.50)SCR BLK	90	
-	REF	-	2-22603-0	SCR,HEX HD(8-32x.31)FEED FINGER	86	
-	2	-	1-21000-3	SCR,SHC(4-40x.25)F ST GUIDE	85	
-	REF	-	22733-9	SCR,BHC(8-32x.50 SL)STRIPPER	84	
-	1	-	3-22603-1	SCR,HEX(10-32x.38)SG ADJ BL	81	
-	2	-	463310-6	BLADE, STRIPPING (#22)	77	
-	1	-	690603-1	SPRING, ASSIST	74	
-	1	-	23030-1	SCR,SKT CAP(6-32x.25)CP DSC	73	
-	77	-2	U/M	PART NO	DESCRIPTION	ITEM NO
PARTS LIST						

-	70					
-	69					
-	68					
-	67					
-	66					
-	65					
-	64					
-	63					
-	62					
-	61					
-	60					
-	59					
-	58					
-	57					
-	56	REF	694433-8	PAWL, FEED		
-	55					
-	54					
-	53					
-	52					
-	51	1	811242-2	BUMPER, HOLDDOWN		
-	50	1	690753-1	SPACER, TONKER		
-	49	1	7-21002-9	BOLT, CRIMPER(5/16x1.00)		
-	48	1	690602-6	CAM, PRE-FEED 1.62 STROKE		
-	47					
-	46					
-	45	1	690191-1	PLUG, NYLON		
-	44	1	455673-1	RAM		
-	43	1	690125-1	WASHER, LAMINATED		
-	42	1	640124-1	WASHER, RAM		
-	41					
-	40	1	23241-6	BALL, STEEL		
-	39	1	690170-1	SPRING, COMPRESSION		
-	38	1	690142-1	DISC, INSULATION		
-	37	1	354777-1	WIRE DISC, PLASTIC		
-	36	1	22480-5	WASHER, SPRING		
-	35	1	690212-1	POST, RAM		
-	34	1	692776-1	SUPPORT, TERMINAL		
-	33	1	462544-1	PLATE, BASE SPECIAL		
-	32	1	690432-3	SCREW, ADJUSTMENT		
-	31	1	462543-1	BLOCK, SCREW SPECIAL		
-	30	1	455689-1	BLOCK, STRIP GUIDE ADJ		
-	29	1	458144-1	PLATE, STRIP GUIDE		
-	28	1	1-455888-0	SPACER, FRONT SHEAR DEP		
-	27	2	1-22284-0	SPRING, DRAG		
-	26	1	240793-1	LEVER, DRAG RELEASE		
-	25	1	240792-1	DRAG, TERMINAL		
-	24	1	90765-4	GUIDE, STRIP (REAR)		
-	23	1	690438-1	GUIDE, STRIP (FRONT)		
-	22					
-	21	1	463756-1	GUIDE, SCRAP		
-	20					
-	19	REF	462615-1	STRIPPER		
-	18					
-	17					
-	16					
-	15					
-	14					
-	13					
-	12	1	3-22280-3	SPRING, SHEAR		
-	11	1	690461-2	STOP, SHEAR (FRONT)		
-	10	1	462548-1	HOLDER, SHEAR (FRONT) SP		
-	9	1	462547-1	SHEAR, FLOAT (FRONT) SP		
-	8	1	8-458834-6	ANVIL		
-	7	1	5-240641-1	SPACER, DEPRESSOR (REAR)		
-	6					
-	5	1	462838-1	DEPRESSOR, SHEAR (FRONT) SP		
-	4	1	2-238011-2	SPACER, BLOCK CRIMPER		
-	3	1	4-456135-4	CRIMPER, INSULATION		
-	2	1	455888-2	SPACER, CRIMPER		
-	1	1	1-456403-2	CRIMPER, WIRE		
-	77	-2	U/M	PART NO	DESCRIPTION	ITEM NO
PARTS LIST						

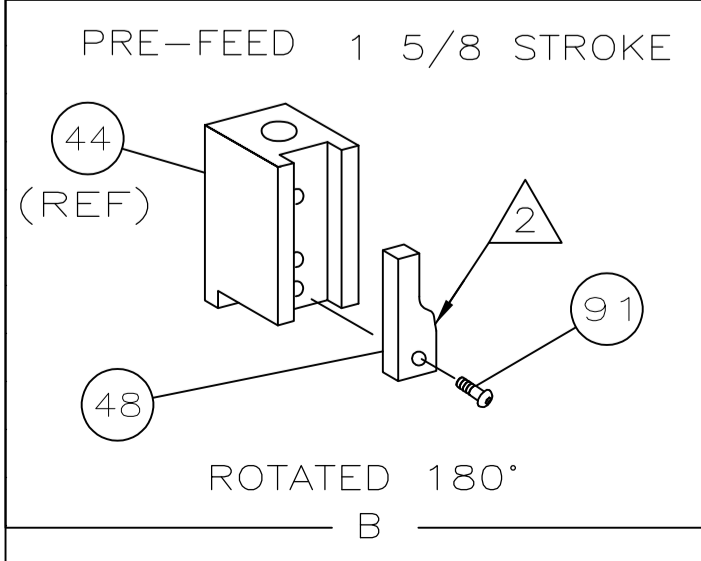

- Δ 1 RECOMMENDED SPARE PARTS.
- Δ 2 GREASE LIGHTLY.
- Δ 3 ITEM NOT SHOWN
- Δ 4 #20 WIRE IS NOT RECOMMENDED.

THIS DRAWING IS A CONTROLLED DOCUMENT.

DIMENSIONS: INCHES	TOLERANCES UNLESS OTHERWISE SPECIFIED:	DATE: 9/9/93	BY: D. SALTZER	APPROVED: E. KRISTMAN	NAME: E. KRISTMAN
0. PLC ± .005	1. PLC ± .002	10-5-93			
2. PLC ± .001	3. PLC ± .0005				
4. PLC ± .0002	ANGLES ± .001				
MATERIAL: -	FINISH: -	PRODUCT SPEC: -	APPLICATION SPEC: -	SIZE: A1	CAGE CODE: 00779
CUSTOMER DRAWING		SCALE: -	SHEET: 1 of 1	REV: P	

Tyco Electronics Corporation
 Harrisburg, PA 17105-3608

STRIPPER CRIMPER APPLICATOR