

7 6 5 4 3 2 1

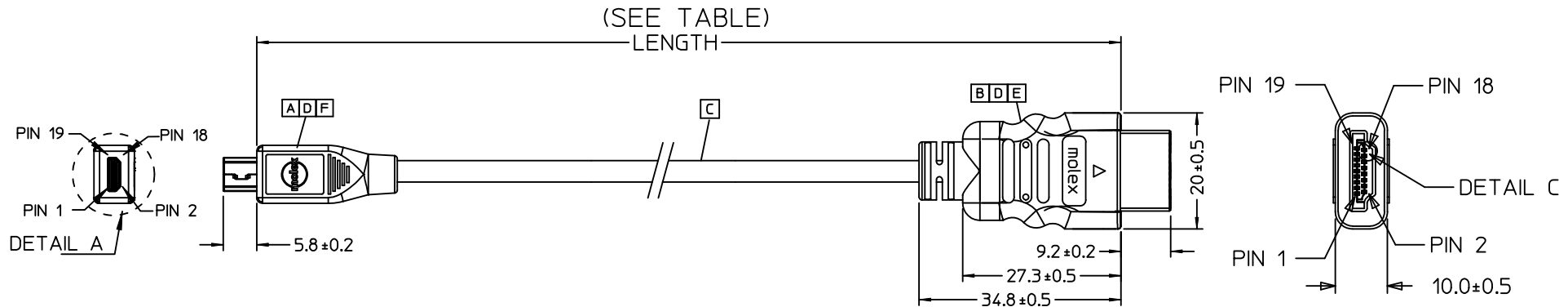

**P1** HDMI D TYPE(M)

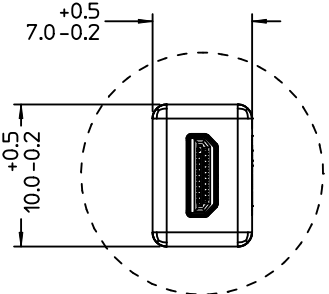
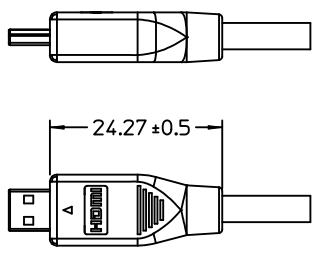

DETAIL A SCALE 2:1

HDMI A TYPE(M) **P2**

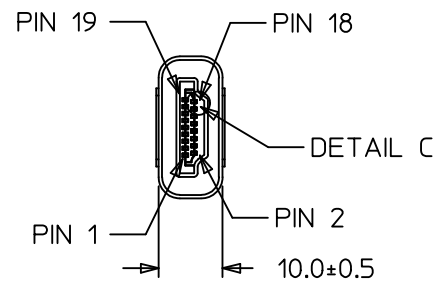
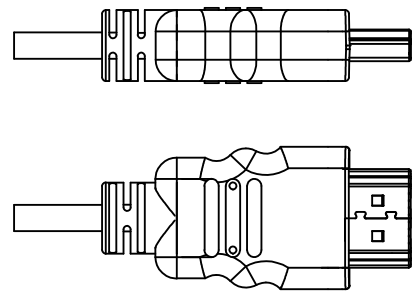

DETAIL C SCALE 4:1

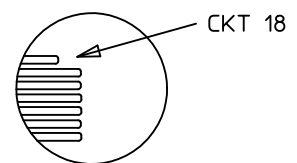

Update ES-002 to HDMI of test SPEC. EC NO: DG2011-0060 DRW: FZHANG01 CHKD: APPR: BLAU 2010/08/20 2010/08/20 2010/09/09	DESCRIPTION B	QUALITY SYMBOLS ▽=0 ▽=0	GENERAL TOLERANCES (UNLESS SPECIFIED)		DIMENSION STYLE MM ONLY		SCALE ---	DESIGN UNITS METRIC	THIRD ANGLE PROJECTION		
					mm	INCH	DRAWN BY FZHANG01	DATE 2010/08/04	TITLE HDMI A-D W/HEAC CABLE ASS'Y		
			4 PLACES	± ---	± ---		CHECKED BY PHZHU	DATE 2010/08/04			
			3 PLACES	± ---	± ---		APPROVED BY BLAU	DATE 2010/08/05	MOLEX INCORPORATED		
			2 PLACES	± 0.25	± ---		MATERIAL NO.	DOCUMENT NO.			
1 PLACE	± 0.5	± ---		SEE TABLE		SD-68786-011	1 OF 2				
DRAFT WHERE APPLICABLE MUST REMAIN WITHIN DIMENSIONS				THIS DRAWING CONTAINS INFORMATION THAT IS PROPRIETARY TO MOLEX INCORPORATED AND SHOULD NOT BE USED WITHOUT WRITTEN PERMISSION							

6 5 4 3 2 1

MX P/N	PDR No.	GAUGE	LENGTH	RAW CABLE	DESCRIPTION	TEST SPEC
68786-0014	C301/10	32 AWG	1000±30	HDMI CABLE W/ETHERNET BLK OD4.6	HDMI CABLE ASS'Y W/ETHERNET	HDMI CAT2 W/HEAC
68786-0017	C307/10	32 AWG	1500±40	HDMI CABLE W/ETHERNET BLK OD4.6	HDMI CABLE ASS'Y W/ETHERNET	HDMI CAT2 W/HEAC
68786-0018	C308/10	32 AWG	2000±50	HDMI CABLE W/ETHERNET BLK OD4.6	HDMI CABLE ASS'Y W/ETHERNET	HDMI CAT2 W/HEAC
68786-0015	C302/10	34 AWG	1000±30	HDMI CABLE W/ETHERNET BLK OD4.2	HDMI CABLE ASS'Y W/ETHERNET	HDMI CAT2 W/HEAC
68786-0019	C309/10	34 AWG	1500±40	HDMI CABLE W/ETHERNET BLK OD4.2	HDMI CABLE ASS'Y W/ETHERNET	HDMI CAT2 W/HEAC
68786-0020	C310/10	34 AWG	2000±50	HDMI CABLE W/ETHERNET BLK OD4.2	HDMI CABLE ASS'Y W/ETHERNET	HDMI CAT2 W/HEAC
68786-0016	C303/10	36 AWG	1000±30	HDMI CABLE W/ETHERNET BLK OD3.7	HDMI CABLE ASS'Y W/ETHERNET	HDMI CAT2 W/HEAC
68786-0021	C311/10	36 AWG	1500±40	HDMI CABLE W/ETHERNET BLK OD3.7	HDMI CABLE ASS'Y W/ETHERNET	HDMI CAT2 W/HEAC
68786-0022	C312/10	36 AWG	2000±50	HDMI CABLE W/ETHERNET BLK OD3.7	HDMI CABLE ASS'Y W/ETHERNET	HDMI CAT1 W/HEAC

WIRE CHART			
P1	FUNCTION	P2	WIRE COLOR
Pin 1	HOT PLUG DETECT / HEAC-	Pin 19	ORANGE
Pin 16	DDC/CEC/HEAC SHIELD (Unit A5)	Pin 17	DRAIN WIRE
Pin 2	UTILITY / HEAC+	Pin 14	WHITE
Pin 3	TMDS DATA2+	Pin 1	WHITE
Pin 4	TMDS DATA2 GND (Unit A3)	Pin 2	DRAIN WIRE
Pin 5	TMDS DATA2-	Pin 3	RED
Pin 6	TMDS DATA1+	Pin 4	WHITE
Pin 7	TMDS DATA1 GND (Unit A2)	Pin 5	DRAIN WIRE
Pin 8	TMDS DATA1-	Pin 6	GREEN
Pin 9	TMDS DATA0+	Pin 7	WHITE
Pin 10	TMDS DATA0 GND (Unit A4)	Pin 8	DRAIN WIRE
Pin 11	TMDS DATA0-	Pin 9	BLUE
Pin 12	TMDS CLOCK+	Pin 10	WHITE
Pin 13	TMDS CLOCK GND (Unit A1)	Pin 11	DRAIN WIRE
Pin 14	TMDS CLOCK-	Pin 12	BROWN
Pin 15	CEC	Pin 13	BLACK
Pin 17	SCL	Pin 15	YELLOW
Pin 18	SDA	Pin 16	GRAY
Pin 19	+5V POWER	Pin 18	VIOLET
SHELL		SHELL	BRAID

NOTES:

1. P1 & P2 SIDE INNERMOLD WITH PE RESIN  
P1 & P2 SIDE OUTERMOLD WITH PVC RESIN
2. ELECTRICAL PERFORMANCE HDMI SPEC 1.4.
3. THIS CABLE ASS'Y SHOULD WITHSTAND 5KG PULL FORCE FOR 1 MIN.
4. BENDING TEST  
100 CYCLES IN EACH OF 2 PLANES DETAIL CONDITION REFER TO ANSI/EIA-364-41C, CONDITION I.
5. THIS PRODUCT MUST MEET PS-40000-5016 COMPLIANCE.

F	Copper foil dual conductive 28*16.5mm	1
E	HDMI CONN 19P MALE WHT 30U''Au SOLDER TY	1
D	Adhesve Replcmnt of 411 Loctite#416 HF	AS
C	RAW CABLE (SEE CHART)	AS
B	PRE-CUT C.Foil 47X23mm T=25U HF	1
A	MICROHDMI PLUG CONNECTOR 0.4MM PITCH	1
ITEM	DESCRIPTION	QTY.

Update ES-002 to HDMI of test SPEC. EC NO: DG2011-0060 DRWN:FZHANG01 CHKD: APPR:BLAU 2010/08/20 2010/08/20 2010/09/09	QUALITY SYMBOLS 	GENERAL TOLERANCES (UNLESS SPECIFIED)		DIMENSION STYLE		SCALE	DESIGN UNITS	THIRD ANGLE PROJECTION		
				MM ONLY		---	METRIC			
				DRAWN BY DATE		TITLE				
				CHECKED BY DATE		MOLEX INCORPORATED				
		APPROVED BY DATE		BLAU 2010/08/05		DOCUMENT NO.		SHEET NO.		
		ANGULAR ± 1 °		SEE TABLE		SD-68786-011		2 OF 2		
		DRAFT WHERE APPLICABLE MUST REMAIN WITHIN DIMENSIONS		SIZE A 4		THIS DRAWING CONTAINS INFORMATION THAT IS PROPRIETARY TO MOLEX INCORPORATED AND SHOULD NOT BE USED WITHOUT WRITTEN PERMISSION				

7 6 5 4 3 2 1

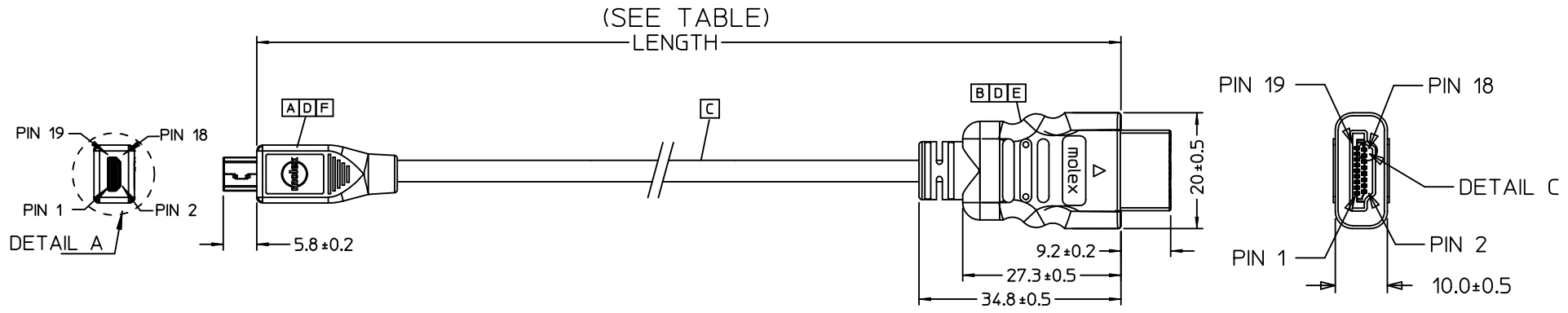

**P1** HDMI D TYPE(M)

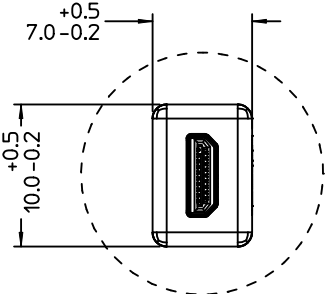
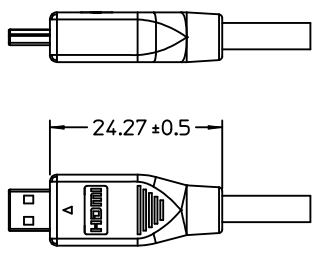

DETAIL A SCALE 2:1

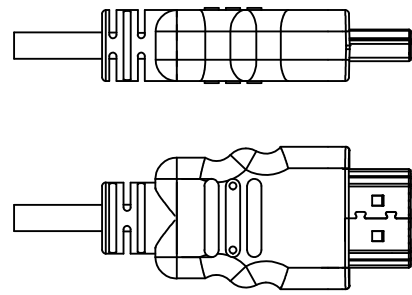

HDMI A TYPE(M) **P2**

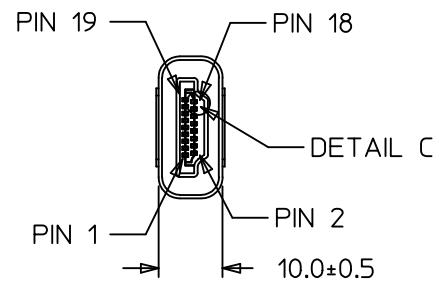

DETAIL C SCALE 4:1

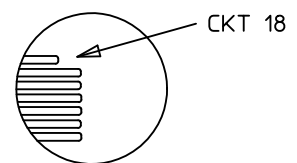

Update ES-002 to HDMI of test SPEC. EC NO: DG2011-0060 DRWN:FZHANG01 CHKD: APPR:BLAU 2010/08/20 2010/08/20 2010/09/09	DESCRIPTION	QUALITY SYMBOLS	GENERAL TOLERANCES (UNLESS SPECIFIED)		DIMENSION STYLE		SCALE	DESIGN UNITS	THIRD ANGLE PROJECTION		
	REV	DESCRIPTION	▼=0 ▽=0	mm	INCH	MM ONLY	---	METRIC			
	B			4 PLACES	± ---	± ---	DRAWN BY	DATE	TITLE		
				3 PLACES	± ---	± ---	FZHANG01	2010/08/04			
				2 PLACES	± 0.25	± ---	CHECKED BY	DATE	MOLEX INCORPORATED		
			1 PLACE	± 0.5	± ---	PHZHU	2010/08/04	SD-68786-011			
			ANGULAR ± 1 °			APPROVED BY	DATE				DOCUMENT NO.
			DRAFT WHERE APPLICABLE MUST REMAIN WITHIN DIMENSIONS			BLAU	2010/08/05	SHEET NO.			
						MATERIAL NO.					1 OF 2
						SEE TABLE		THIS DRAWING CONTAINS INFORMATION THAT IS PROPRIETARY TO MOLEX INCORPORATED AND SHOULD NOT BE USED WITHOUT WRITTEN PERMISSION			
						SIZE					
						A4					

6 5 4 3 2 1

MX P/N	PDR No.	GAUGE	LENGTH	RAW CABLE	DESCRIPTION	TEST SPEC
68786-0014	C301/10	32 AWG	1000±30	HDMI CABLE W/ETHERNET BLK OD4.6	HDMI CABLE ASS'Y W/ETHERNET	HDMI CAT2 W/HEAC
68786-0017	C307/10	32 AWG	1500±40	HDMI CABLE W/ETHERNET BLK OD4.6	HDMI CABLE ASS'Y W/ETHERNET	HDMI CAT2 W/HEAC
68786-0018	C308/10	32 AWG	2000±50	HDMI CABLE W/ETHERNET BLK OD4.6	HDMI CABLE ASS'Y W/ETHERNET	HDMI CAT2 W/HEAC
68786-0015	C302/10	34 AWG	1000±30	HDMI CABLE W/ETHERNET BLK OD4.2	HDMI CABLE ASS'Y W/ETHERNET	HDMI CAT2 W/HEAC
68786-0019	C309/10	34 AWG	1500±40	HDMI CABLE W/ETHERNET BLK OD4.2	HDMI CABLE ASS'Y W/ETHERNET	HDMI CAT2 W/HEAC
68786-0020	C310/10	34 AWG	2000±50	HDMI CABLE W/ETHERNET BLK OD4.2	HDMI CABLE ASS'Y W/ETHERNET	HDMI CAT2 W/HEAC
68786-0016	C303/10	36 AWG	1000±30	HDMI CABLE W/ETHERNET BLK OD3.7	HDMI CABLE ASS'Y W/ETHERNET	HDMI CAT2 W/HEAC
68786-0021	C311/10	36 AWG	1500±40	HDMI CABLE W/ETHERNET BLK OD3.7	HDMI CABLE ASS'Y W/ETHERNET	HDMI CAT2 W/HEAC
68786-0022	C312/10	36 AWG	2000±50	HDMI CABLE W/ETHERNET BLK OD3.7	HDMI CABLE ASS'Y W/ETHERNET	HDMI CAT1 W/HEAC

WIRE CHART			
P1	FUNCTION	P2	WIRE COLOR
Pin 1	HOT PLUG DETECT / HEAC-	Pin 19	ORANGE
Pin 16	DDC/CEC/HEAC SHIELD (Unit A5)	Pin 17	DRAIN WIRE
Pin 2	UTILITY / HEAC+	Pin 14	WHITE
Pin 3	TMDS DATA2+	Pin 1	WHITE
Pin 4	TMDS DATA2 GND (Unit A3)	Pin 2	DRAIN WIRE
Pin 5	TMDS DATA2-	Pin 3	RED
Pin 6	TMDS DATA1+	Pin 4	WHITE
Pin 7	TMDS DATA1 GND (Unit A2)	Pin 5	DRAIN WIRE
Pin 8	TMDS DATA1-	Pin 6	GREEN
Pin 9	TMDS DATA0+	Pin 7	WHITE
Pin 10	TMDS DATA0 GND (Unit A4)	Pin 8	DRAIN WIRE
Pin 11	TMDS DATA0-	Pin 9	BLUE
Pin 12	TMDS CLOCK+	Pin 10	WHITE
Pin 13	TMDS CLOCK GND (Unit A1)	Pin 11	DRAIN WIRE
Pin 14	TMDS CLOCK-	Pin 12	BROWN
Pin 15	CEC	Pin 13	BLACK
Pin 17	SCL	Pin 15	YELLOW
Pin 18	SDA	Pin 16	GRAY
Pin 19	+5V POWER	Pin 18	VIOLET
SHELL		SHELL	BRAID

NOTES:

1. P1 & P2 SIDE INNERMOLD WITH PE RESIN  
P1 & P2 SIDE OUTERMOLD WITH PVC RESIN
2. ELECTRICAL PERFORMANCE HDMI SPEC 1.4.
3. THIS CABLE ASS'Y SHOULD WITHSTAND 5KG PULL FORCE FOR 1 MIN.
4. BENDING TEST  
100 CYCLES IN EACH OF 2 PLANES DETAIL CONDITION REFER TO ANSI/EIA-364-41C, CONDITION I.
5. THIS PRODUCT MUST MEET PS-40000-5016 COMPLIANCE.

F	Copper foil dual conductive 28*16.5mm	1
E	HDMI CONN 19P MALE WHT 30U''Au SOLDER TY	1
D	Adhesve Replcmnt of 411 Loctite#416 HF	AS
C	RAW CABLE (SEE CHART)	AS
B	PRE-CUT C.Foil 47X23mm T=25U HF	1
A	MICROHDMI PLUG CONNECTOR 0.4MM PITCH	1
ITEM	DESCRIPTION	QTY.

Update ES-002 to HDMI of test SPEC. EC NO: DG2011-0060 DRWN:FZHANG01 CHKD: APPR:BLAU 2010/08/20 2010/08/20 2010/09/09	QUALITY SYMBOLS ▼=0 ▽=0	GENERAL TOLERANCES (UNLESS SPECIFIED)		DIMENSION STYLE		SCALE	DESIGN UNITS	THIRD ANGLE PROJECTION
				MM ONLY		---	METRIC	
				DRAWN BY DATE		TITLE		
				CHECKED BY DATE		MOLEX INCORPORATED		
		APPROVED BY DATE		DOCUMENT NO.		SHEET NO.		
		ANGULAR ± 1 °		SEE TABLE		SD-68786-011		
		DRAFT WHERE APPLICABLE MUST REMAIN WITHIN DIMENSIONS		THIS DRAWING CONTAINS INFORMATION THAT IS PROPRIETARY TO MOLEX INCORPORATED AND SHOULD NOT BE USED WITHOUT WRITTEN PERMISSION		2 OF 2		