



GlobalTech Display

A Professional LCD Displays Provider

TFT LCD Display Specification

PN: GLT1011280800IS2-USBCTP-HDMI

Overview:

- 10.1" Diagonal
- IPS, Full View Angle
- Driver: EK79202
- 16.7M Colors
- 800 Nits
- 1280 x 800 Pixels
- Transmissive/Normally Black
- LVDS, HDMI Interface
- USB CTP
- RoHS Compliant

9825 Widmer Road, Lenexa, KS 66215, USA | Tel: 913-828-5685 Fax: 913-273-4397

Email: sales@gtdisplays.com Website: www.gtdisplays.com

Table of Contents

1. Record of Revision	3
2. General Specifications.....	4
3. PCB Board	4
4. PIN-MAP	5
5. Electrical Circuit	6
6. Input/Output Terminals	7
7. Absolute Maximum Ratings.....	8
8. Electrical Characteristics	9
9. Optical Characteristics.....	13
10. Environmental / Reliability Tests.....	16
11. Mechanical Drawing.....	18
12. Packing.....	19
13. TFT-LCD Module Inspection Criteria	20
14. Precautions for Use of LCD modules	24

2. General Specifications

Feature		Spec
Characteristics	Size	10.1 inch
	Resolution	1280(H) x 800(V)
	Interface	LVDS
	Connect type	Connector
	Color Depth	16.7M
	Technology type	a-Si
	Display Spec. Pixel pitch (mm)	0.1695(H) x 0.1695(V)
	Pixel Configuration	R.G.B. Vertical Stripe
	Display Mode	Normally Black
	Driver IC	EK79202
	Viewing Direction	ALL
Mechanical	LCM (W x H x D) (mm)	229.46 x 149.10 x 6.52
	Active Area (mm)	216.96 x 135.60
	Touch Panel	CTP
	Weight (g)	~480g
	LED Numbers	45 LEDs

Note 1: Requirements on Environmental Protection: RoHS

Note 2: LCM weight tolerance: +/- 5%

3. PCB Board Mechanical Drawing

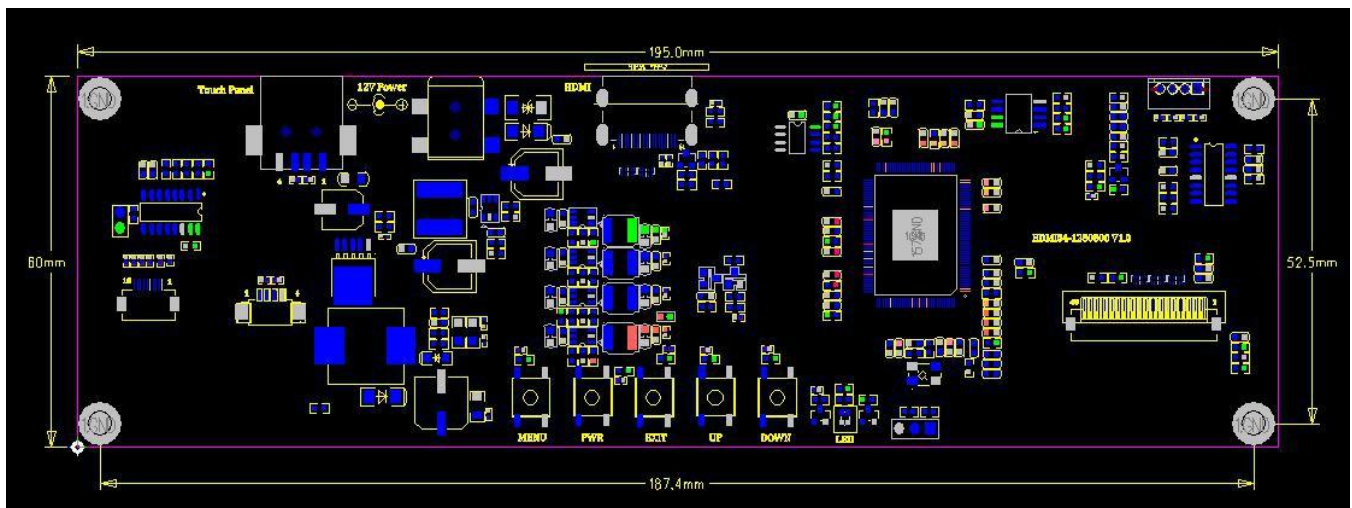



4. PIN-MAP

POWER CONNECTOR - DC JACK: DC005 (5.5-2.1MM)

Pin	Signal	Description
1	VDD	Power supply +12V
2	GND	GND

TOUCH CONNECTOR - USB: TYPE A USB

Pin	Signal	Description
1	USB 5V	Power supply 5V
2	DM	Data-
3	DP	Data+
4	GND	Ground

HDMI CONNECTOR - HDMI: HDMI-019S

Pin	Signal	Description
1	TMDS Data 2+	TMDS Transition differential signal 2+
2	TMDS Data2 Sh	Data2 Shielding ground
3	TMDS Data 2-	TMDS Transition differential signal 2-
4	TMDS Data 1+	TMDS Transition differential signal 1+
5	TMDS Data1 Sh	Data1 Shielding ground
6	TMDS Data 1-	TMDS Transition differential signal 1-
7	TMDS Data 0+	TMDS Transition differential signal 0+
8	TMDS Data 0 S	Data0 Shielding ground
9	TMDS Data 0-	TMDS Transition differential signal 0-
10	TMDS Clock+	TMDS Transition differential signal Clock+
11	TMDS Clock Sh	Clock Shielding ground

12	TMDS Clock-	TMDS Transition differential signal Clock-
13	CEC	Electronic protocol CEC
14	NC	NC
15	SCL	I2C Clock Line
16	SDA	I2C DATA Line
17	DDC/CEC GND	Data display channel
18	+5V	+5V Power
19	Hot Plug Detec	Hot Plug Detec

OSD:

Pin	Signal	Description
KEY1	MENU	Popup menu KEY
KEY2	PWR	Power KEY
KEY3	EXIT	Exit KEY
KEY4	UP	Up KEY
KEY5	DOWN	Down KEY

5. Electrical Circuit

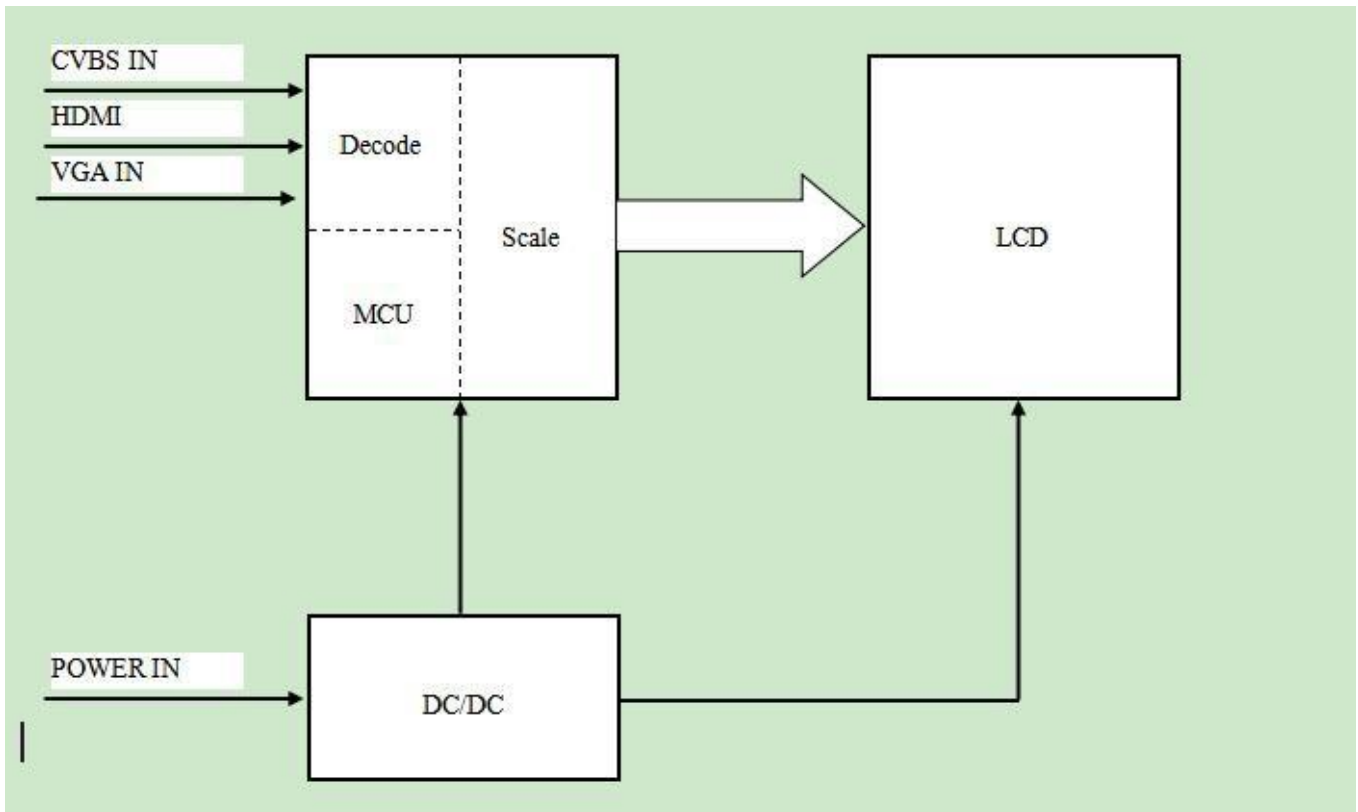

6. Input/Output Terminals

No.	Symbol	Description	Note
1	NC	No connection	
2-3	VDD (3.3V)	Power Supply	
4	NC	No connection	
5	RESET(NC)	No connection	
6	STBYB(NC)	No connection	
7	GND	Ground	
8	RXIN0-	- LVDS differential data input	
9	RXIN0+	+ LVDS differential data input	
10	GND	Ground	
11	RXIN1-	- LVDS differential data input	
12	RXIN1+	+ LVDS differential data input	
13	GND	Ground	
14	RXIN2-	- LVDS differential data input	
15	RXIN2+	+ LVDS differential data input	
16	GND	Ground	
17	RXCLK-	- LVDS differential clock input	
18	RXCLK+	+ LVDS differential clock input	
19	GND	Ground	
20	RXIN3-	- LVDS differential data input	
21	RXIN3+	+ LVDS differential data input	
22	GND	Ground	
23	SDA(NC)	No connection	
24	SCL(NC)	No connection	
25	GND	Ground	
26	CS(NC)	No connection	
27	NC	No connection	

28	LVBIT(NC)	No connection	
29	NC	No connection	
30	GND	Ground	
31-32	LEDK	Power for LED backlight (Cathode)	
33-38	NC	No connection	
39-40	LEDA	Power for LED backlight (Anode)	

CTP PIN-MAP

Pin	Signal	Description
1	USB-VDD5V	Power supply
2	USB-DN-	Data- input
3	USB-DP+	Data+ input
4	USB-GND	Ground

7. Absolute Maximum Ratings

Item	Symbol	MIN	Typ	MAX	Unit
Supply Voltage	VDD	-0.3	3.3	3.6	V
Input voltage “H”level	VIH	0.7VDD	-	VDD	V
Input voltage “L”level	VIL	0	-	0.3VDD	V
Operating Temperature	TOPR	-20	-	70	°C
Storage Temperature	TSTG	-30	-	80	°C

8. Electrical Characteristics

8.1 Power On/Off Sequence

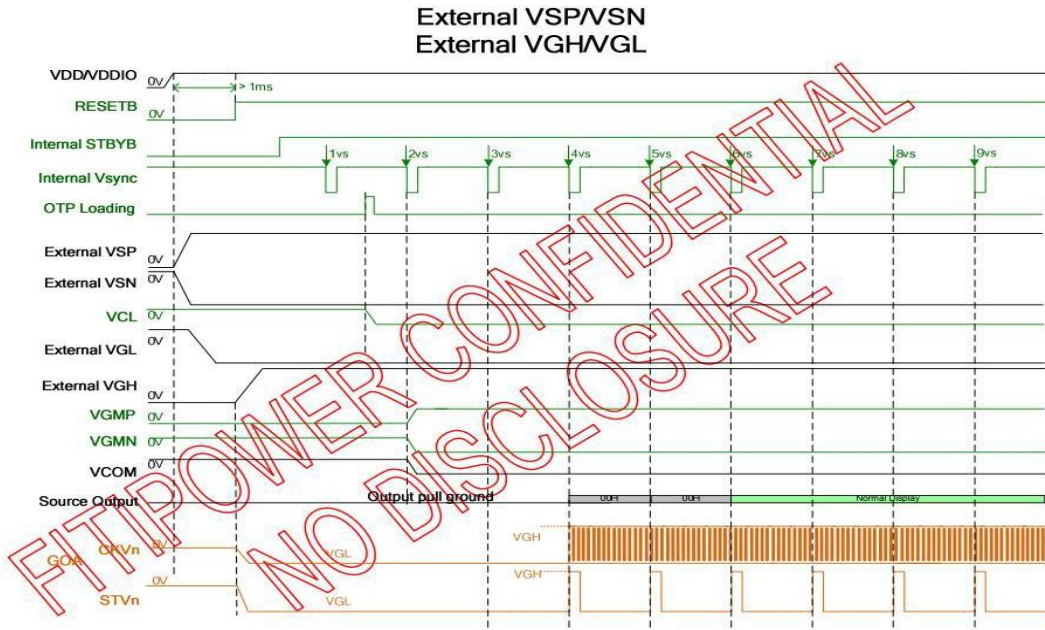

Power on sequence with PMODE=H

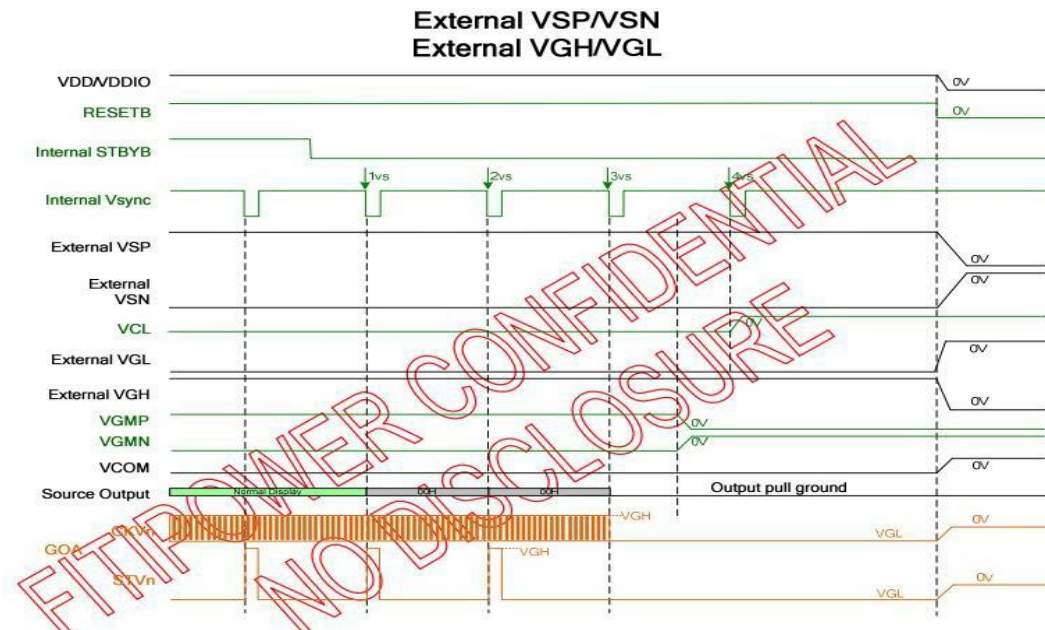

Power off sequence with PMODE=H

8.2 Driving Backlight

Item	Symbol	MIN	TYP	MAX	Unit	Remark
Forward Current	IF	-	360	-	mA	
Forward Voltage	VF	14	16	18	V	
Backlight Power consumption	WBL	-	5.76	-	W	
LED Lifetime		-	50000	-	Hrs	

Note 1: Each LED: IF =40 mA, VF =2.7~3.6V.

Note 2: Optical performance should be evaluated at Ta=25°C only.

Note 3: If LED is driven by high current, high ambient temperature & humidity condition. The life Time of LED will be reduced. Operating life means brightness goes down to 50% initial brightness. Typical operating life time is estimated data.

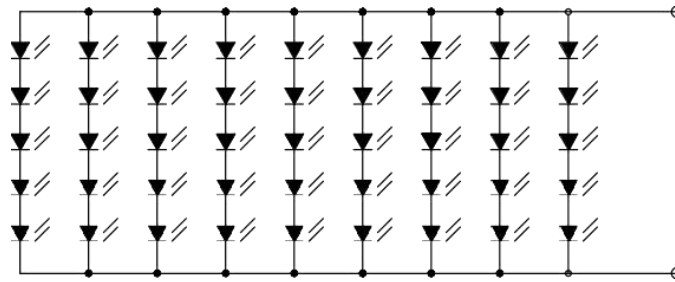

CIRCUIT DIAGRAM

8.3 CTP Electrical Characteristics

FPC Design	Item	Description	Remark
COF	IC solution on TP Model	IL2511	
	Touch Count Max	5 point	
	Display Resolution	1280*800	
	Interface Type	USB	
	Origin of Coordinate	Top left corner	

Parameter	Min	Typ	Max	Unit
Interface Signal Voltage	-	3.3	-	V
Power Voltage	VDD	5.0	-	V

8.4 Reset Timing Characteristics

When RESETB of the reset pin equals to Low, it will be in the condition of reset. When it is in the condition of reset, it will make the device recover the initial set.

However, in order to avoid the reset noise cause reset, there is a mechanism to judge about whether the reset is needed or not.

The closed interval of Low can be shown as the following.

(Test condition: VDDIO=2.3V~3.6V, VSS=0V, TA=-20 ~+85)

Parameter	Symbol	Conditions	Spec.			Unit
			Min.	Typ.	Max	
Reset low pulse width	Trst		20	-	-	μs

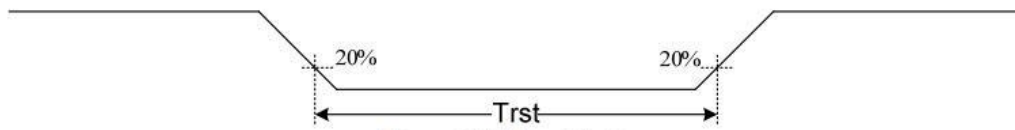
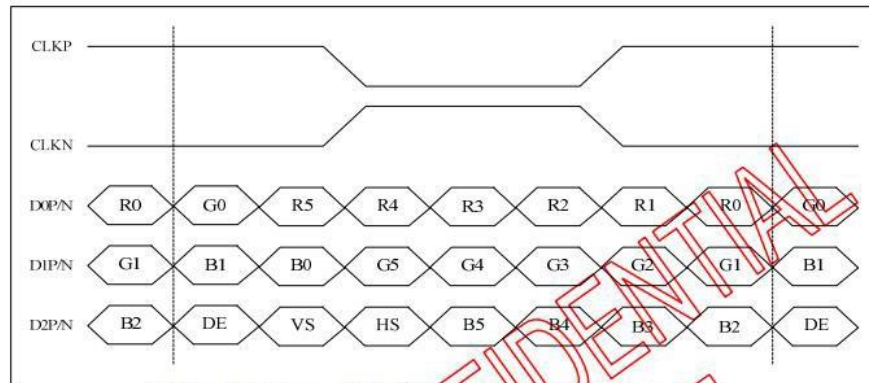
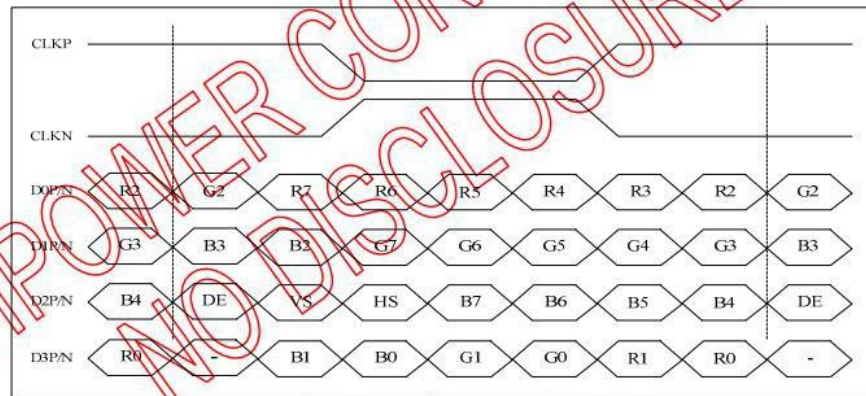

Figure 13.5: Reset timing

8.5 LVDS interface Characteristics



6-bit LVDS input (LVBIT=L, LVFMT=Don't care)



8-bit LVDS input (LVBIT=H, LVFMT=L)

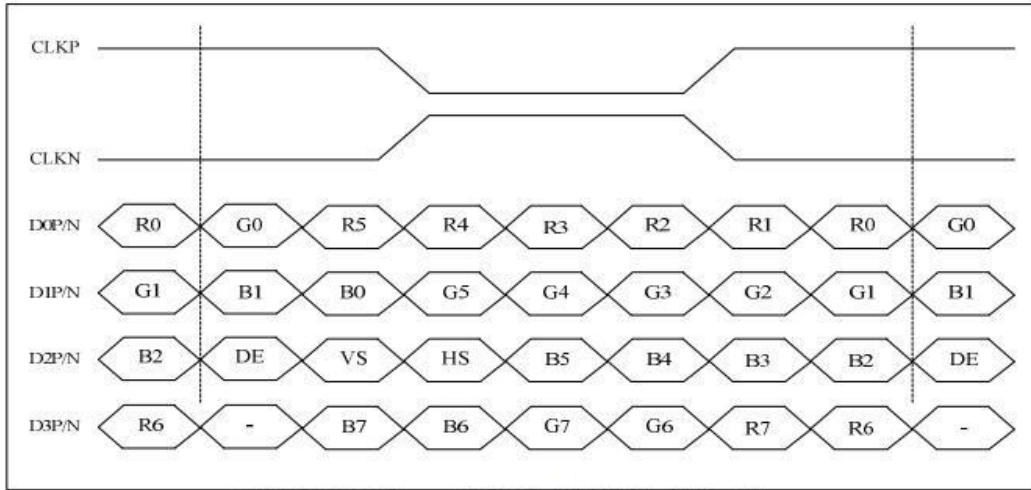

8-bit LVDS input(LVBIT=H, LVFMT=H)

For 1280RGBx800

Parameter	Symbol	Value			Unit
		Min.	Typ.	Max.	
DCLK frequency @Frame rate=60Hz (LVDS)	F _{DCLK}	66.3	72.4	78.9	MHz
HSYNC period time	T _H	1380	1440	1500	DCLK
Horizontal display area	T _{HD}	1280			DCLK
HSYNC pulse width	Min.	1			
	Typ.	-			
	Max.	40			
HSYNC back porch(with pulse width)	T _{HBP}	88	88	88	DCLK
HSYNC front porch	T _{HFP}	12	72	132	DCLK
VSYNC period time	T _V	824	838	872	H
Vertical display area	T _{VD}	800			H
VSYNC pulse width	Min.	1			H
	Typ.	-			
	Max.	20			
VSYNC back porch(with pulse width)	T _{VBP}	23	23	23	H
VSYNC front porch	T _{VFP}	1	15	49	H

9. Optical Characteristics

Items		Symbol	Condition	Min.	Typ.	Max.	Unit	Remark
Viewing angles		θT	Center CR \geq 10		80	-	Degree	Note2
		θB			80	-		
		θL			80	-		
		θR			80	-		
Contrast Ratio		CR	$\theta = 0$	800	1000	-	-	Note1 Note3
Response Time		TON	25°C	-	25	35	ms	Note1 Note4
		TOFF						
Chromaticity	White	XR	Backlight is on	0.568	0.618	0.668		Note1 Note5
		YR		0.278	0.328	0.378		
		XG		0.285	0.335	0.385		
		YG		0.492	0.542	0.592		
		XB		0.086	0.136	0.186		
		YB		0.095	0.145	0.195		
		XW		0.280	0.330	0.380	-	
		YW		0.294	0.344	0.394	-	
Color Gamut		U		45	50	-	%	Note1 Note6
Luminance Uniformity		U		70	75	-	%	Note1 Note6
Luminance		L		700	800		cd/m ²	Note1 Note7

Test Conditions:

1. IF= 30mA (one channel), the ambient temperature is 25°C.
2. The test systems refer to Note 1 and Note 2.

Note 1: Definition of optical measurement system.

The optical characteristics should be measured in dark room. After 5 minutes operation, the optical properties are measured at the center point of the LCD screen. All input terminals LCD panel must be ground when measuring the center area of the panel.



Note 2: Definition of viewing angle range and measurement system.

Viewing angle is measured at the center point of the LCD by CONOSCOPE (ergo-80).

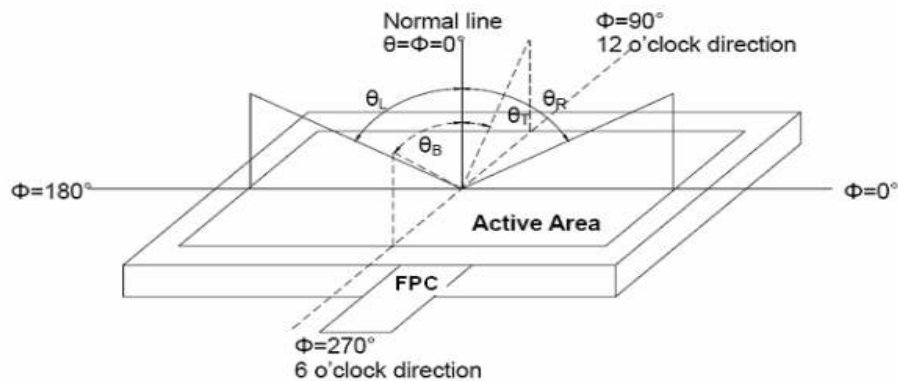

Fig. 1 Definition of viewing angle

Note 3: Definition of contrast ratio

$$\text{Contrast ratio (CR)} = \frac{\text{Luminance measured when LCD on the "White"}}{\text{Luminance measured when LCD on the "Black"}}$$

“White state”: The state is that the LCD should be driven by V_{white} .

“Black state”: The state is that the LCD should be driven by V_{black} .

V_{white} : To be determined, V_{black} : To be determined.

Note 4: Definition of Response time

The response time is defined as the LCD optical switching time interval between “White” state and “Black” state. Rise time (T_{ON}) is the time between photo detector output intensity changed from 90% to 10%. And fall time (T_{OFF}) is the time between photo detector output intensity changed from 10% to 90%.

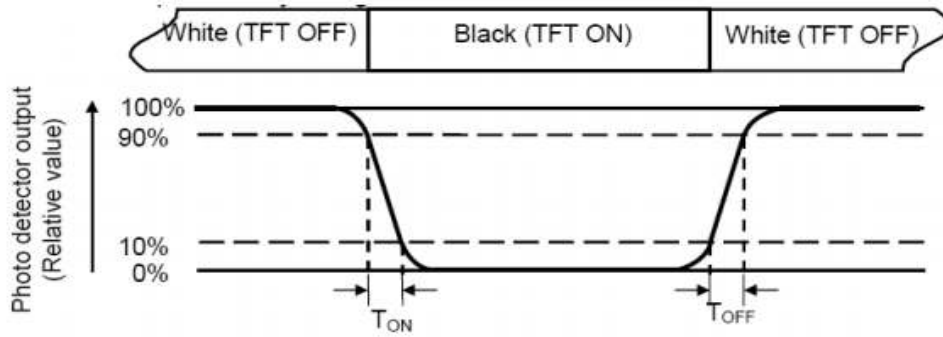

Note 5: Definition of color chromaticity (CIE1931)
 Color coordinates measured at center point of LCD.

Note 6: Definition of Luminance Uniformity

Active area is divided into 9 measuring areas (Refer Fig. 2). Every measuring point is placed at the center of each measuring area.

$$\text{Luminance Uniformity (U)} = \frac{L_{\min}}{L_{\max}} \times 100\%$$

L: Active area length, W: Active area width

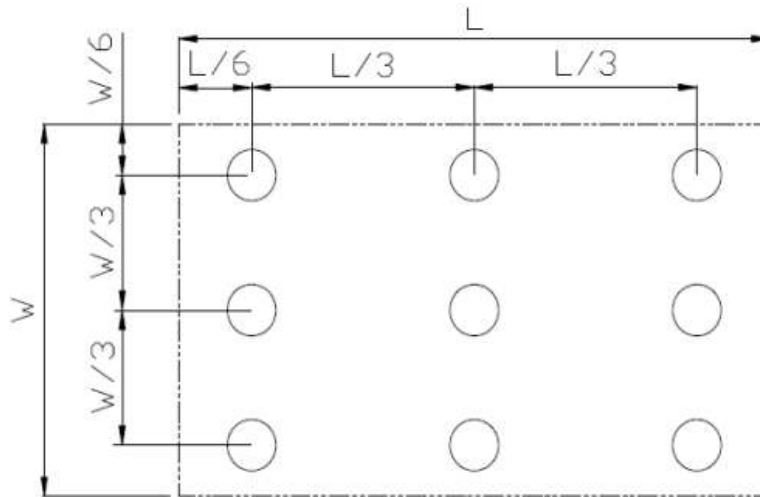

Fig. 2 Definition of uniformity

L_{\max} : The measured maximum luminance of all measurement position.

L_{\min} : The measured minimum luminance of all measurement position.

Note 7: Definition of Luminance:

Measure the luminance of white state at center point.

10. Environmental / Reliability Tests

No	Test Item	Condition	Remarks
1	High Temperature Operation	Ts= +70°C, 96hrs	IEC60068-2-1:2007 GB2423. 2-2008
2	Low Temperature Operation	Ta= -20°C, 96hrs	IEC60068-2-1:2007 GB2423.1-2008
3	High Temperature Storage	Ta= +80°C,96hrs	IEC60068-2-1:2007 GB2423. 2-2008
4	Low Temperature Storage	Ta= -30°C, 96hrs	IEC60068-2-1:2007 GB2423.1-2008
5	High Temperature & Humidity Operation	Ta= +60°C, 90% RH max,96 hours	IEC60068-2-78:2001 GB/T2423.3-2006
6	Thermal Shock (Non-operation)	-30°C 30 min ~ +80°C 30 min Change time: 5min, 20 Cycle	Start with cold temperature, end with high temperature IEC60068-2-14:1984, GB2423.22-2002
7	ESD	C=150pF, R=330 Ω, 5 points/panel , Air:±8KV, 5 times Contact: ±4KV, 5 times (Environment: 15°C ~ 35°C, 30% ~ 60%, 86Kpa ~ 106Kpa)	IEC61000-4-2:2001 GB/T17626.2-2006
8	Vibration (Non-operation)	Frequency range: 10~55Hz, Stroke: 1.5mm , Sweep: 10Hz~55Hz~10Hz 2 hours for each direction of X .Y. Z. (6 hours for total)	IEC60068-2-6:1982 GB/T2423.10-1995
9	Mechanical Shock (Non-operation)	Half Sine Wave 60G ,6ms,±X,±Y,±Z 3times for each direction	IEC60068-2-27:1987 GB/T2423.5—1995
10	Package Drop Test	Height: 60 cm, 1 corner, 3 edges, 6 surfaces	IEC60068-2-32:1990 GB/T2423.8-1995

Notes:

1. The test result shall be evaluated after the sample has been left at room temperature and humidity for 2 hours without load. No condensation shall be accepted. The sample will not be accepted if appear these defects:

- 1).Air bubble in the LCD;
- 2).Seal leak
- 3).Non-display
- 4).missing segments
- 5).Glass crack
- 6).CR reduction >40%
- 7).IDD increase >100%
- 8).Brightness reduction >50%
- 9).Colorcoordinate tolerance >0.05

2.≤7.0 inch: The size of sample is 5pcs;

>7.0 inch: The size of sample is 2pcs;

3. One test sample must complete each test item;

4.In case of malfunction defect caused by ESD damage, if it would be recovered to normal state after resetting, it would be judge as a good part.

In the test of High Temperature Operation and High Temperature & Humidity Operation, the operation temperature is the surface temperature of module.

12. Packing

Packing Method

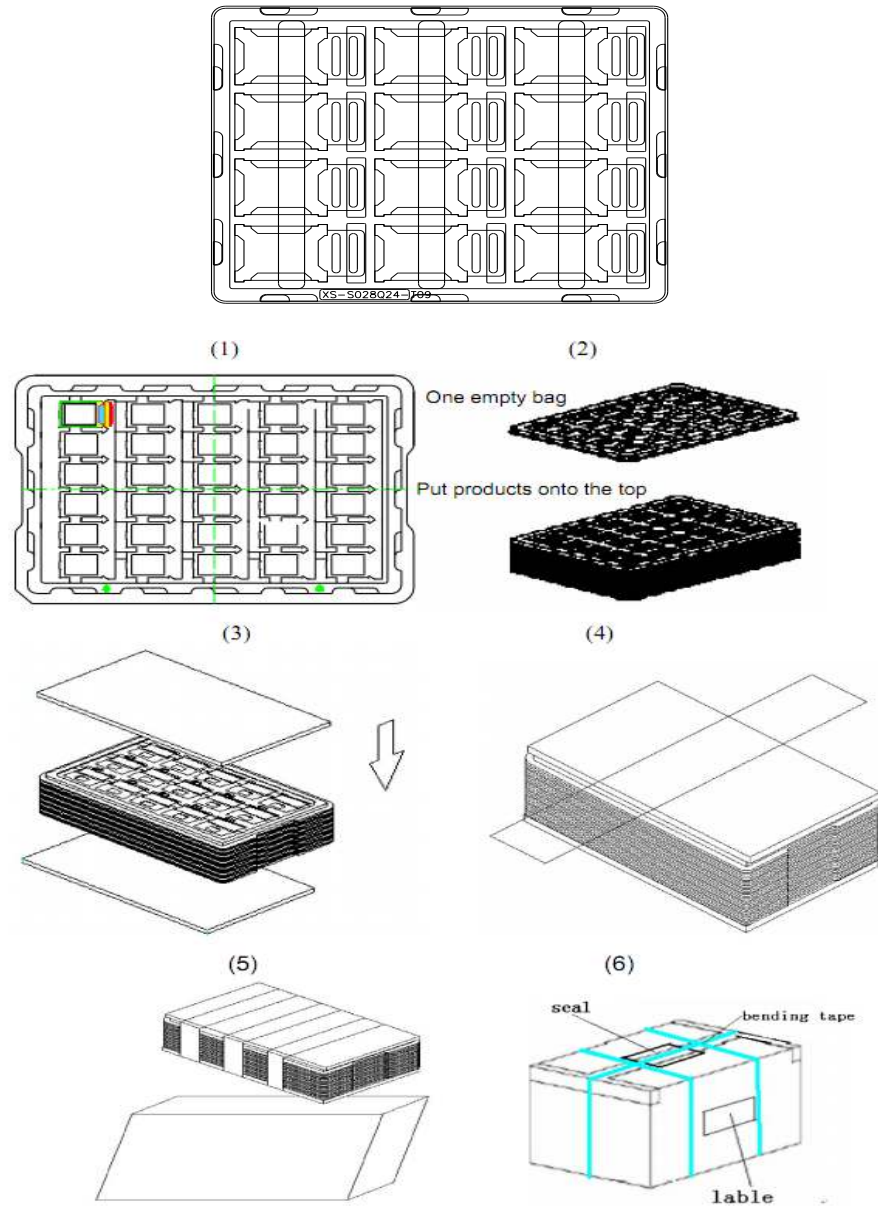

1. Put module into tray cavity.
2. Tray stacking.
3. Put 1 cardboard under the tray stack and 1 cardboard above.
4. Fix the cardboard to the tray stack with adhesive tape.
5. Put the tray stack into carton.
6. Carton sealing with adhesive tape.

13. TFT-LCD Module Inspection Criteria

13.1 Scope

The incoming inspection standards shall be applied to TFT-LCD Modules (hereinafter Called "Modules") that supplied by GlobalTech Display.

13.2 Incoming Inspection

The customer shall inspect the modules within twenty calendar days of the delivery date (the inspection period) at its own cost. The result of the inspection (acceptance or rejection) shall be recorded in writing, and a copy of this writing will be promptly sent to the seller, If the results of the inspecting from buyer does not send to the seller within twenty calendar days of the delivery date. The modules shall be regards as acceptance. Should the customer fail to notify the seller within the inspection period, the buyer's right to reject the modules shall be lapsed and the modules shall be deemed to have been accepted by the buyer

13.3 Inspection Sampling

13.3.1. Lot size: Quantity per shipment lot per model

13.3.2. Sampling type: Normal inspection, Single sampling

13.3.3. Inspection level: II

13.3.4. Sampling table: MIL-STD-105E

13.3.5. Acceptable quality level (AQL)

Major defect: AQL=0.65 Minor defect: AQL=1.00

13.4 Inspection Conditions

13.4.1 Ambient conditions:

a. Temperature: Room temperature $25 \pm 5^\circ\text{C}$

b. Humidity: $(60 \pm 10) \% \text{RH}$

c. Illumination: Single fluorescent lamp non-directive (300 to 700 Lux)

13.4.2 Viewing distance

The distance between the LCD and the inspector's eyes shall be at least $35 \pm 5\text{cm}$.

13.4.3 Viewing Angle

U/D: 45° / 45° , L/R: 45° / 45°

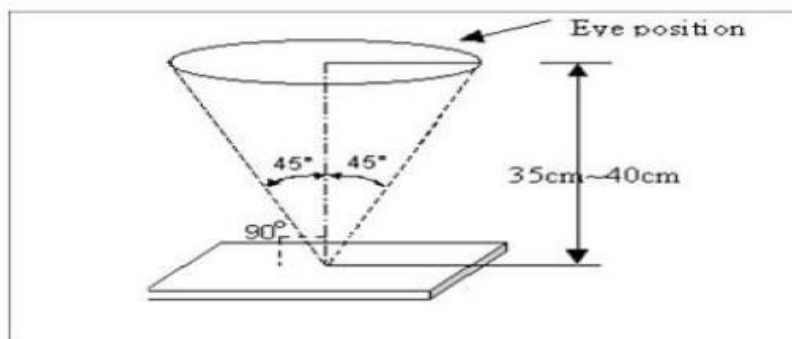

13.5 Inspection Criteria

Defects are classified as major defects and minor defects according to the degree of defectiveness defined herein.

13.5.1 Major defect

Item No	Items to be inspected	Inspection Standard
13.5.1.1	All functional defects	1) No display 2) Display abnormally 3) Short circuit 4) line defect
13.5.1.2	Missing	Missing function component
13.5.1.3	Crack	Glass Crack

13.5.2 Minor defect

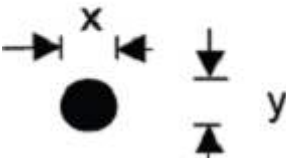
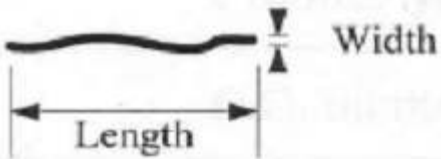
Item No	Items to be inspected	Inspection standard	
13.5.2.1	Spot Defect Including Black spot White spot Pinhole Foreign particle Polarizer dirt	For dark/white spot is defined $\phi = (x+y) / 2$ 	
		Size ϕ (mm)	Acceptable Quantity
		$\phi \leq 0.2$	Ignore
		$0.2 < \phi \leq 0.5$	3
		$0.5 < \phi$	Not allowed
13.5.2.2	Line Defect Including Black line White line Scratch	Define: 	
		Width(mm) Length(mm)	Acceptable Quantity
		$W \leq 0.03$	Ignore

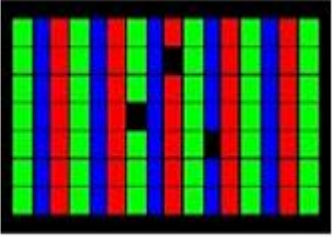
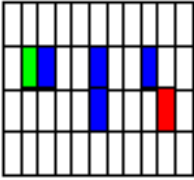
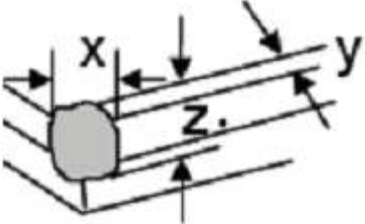
		$0.03 < W \leq 0.04$ $L \leq 5.0$	4		
		$0.04 < W$, or $L > 5.0$	Not allowed		
13.5.2.3	Polarizer Dent/Bubble	Size ϕ (mm)	Acceptable Quantity		
		$\phi \leq 0.25$	Ignore		
		$0.25 < \phi \leq 0.5$	3		
		$0.5 < \phi$	Not allowed		
		Total QTY	3		
13.5.2.4	Electrical Dot Defect	Bright and Black dot define:			
		 			
		and			
					
		Two Adjacent Dot			
Inspection pattern: Full white、Full black、Red、green and blue screens					
		Item	Acceptable Quantity		
			I	O	Total
		Black dot defect	2	3	4
		Bright dot defect	0	3	3
		Total Dot	2	4	5
3% Bright Dot is allowed					
13.5.2.5	Glass defect				
		1. Corner Fragment:			
		Size(mm)	Acceptable Quantity		
		$X \leq 3\text{mm}$ $Y \leq 1\text{mm}$	Ignore T: Glass thickness		

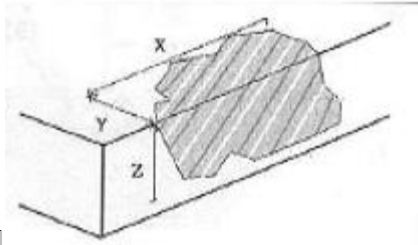
		$Z \leq T$	X: Length Y: Width Z: thickness
		 <p>2. Side Fragment: □</p>	
		Size(mm)	Acceptable Quantity
		$X \leq 5.0\text{mm}$ $Y \leq 1\text{mm}$ $Z \leq T$	T: Glass thickness X: Length Y: Width Z: thickness

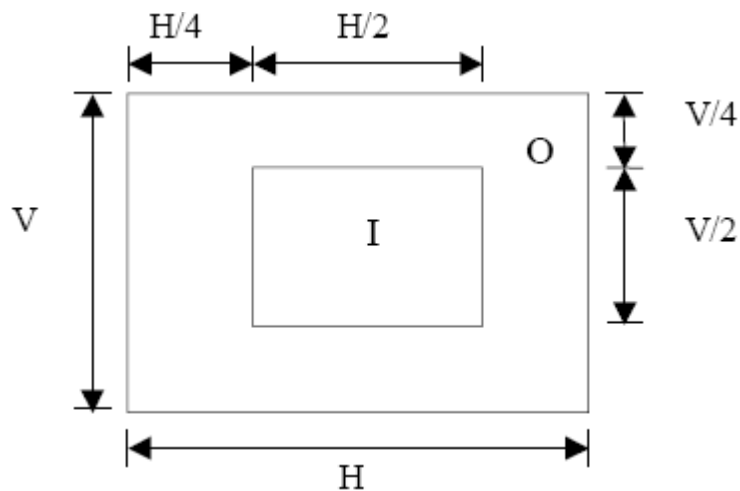

I area & O area

- Note:
- 1). Dot defect is defined as the defective area of the dot area is larger than 50% of the dot area.
 - 2). The distance between two bright dot defects (red, green, blue, and white) should be larger than 15mm.
 - 3). The distance between black dot defects or black and bright dot defects should be more than 5mm apart.
 - 4). Polarizer bubble is defined as the bubble appears on active display area. The defect of polarizer bubble shall be ignored if the polarizer bubble appears on the outside of active display area.

13.6 Mechanics specification

As for the outside dimension, weight of the modules, please refer to product specification
For more details

14. Precautions for Use of LCD modules

14.1 Handling Precautions

14.1.1. The display panel is made of glass. Do not subject it to a mechanical shock by dropping it from a high place, etc.

14.1.2. If the display panel is damaged and the liquid crystal substance inside it leaks out, be sure not to get any in your mouth, if the substance comes into contact with your skin or clothes, promptly wash it off using soap and water.

14.1.3. Do not apply excessive force to the display surface or the adjoining areas since this may cause the color tone to vary.

14.1.4. The polarizer covering the display surface of the LCD module is soft and easily scratched. Handle this polarizer carefully.

14.1.5. If the display surface is contaminated, breathe on the surface and gently wipe it with a soft dry cloth. If still not completely clear, moisten cloth with one of the following solvents:

- Isopropyl alcohol
- Ethyl alcohol

Solvents other than those mentioned above may damage the polarizer. Especially, do not use the following:

- Water
- Ketene

14.1.6. Do not attempt to disassemble the LCD Module.

14.1.7. If the logic circuit power is off, do not apply the input signals.

14.1.8. To prevent destruction of the elements by static electricity, be careful to maintain an optimum work environment.

14.1.8.1. Be sure to ground the body when handling the LCD Modules.

14.1.8.2. Tools required for assembly, such as soldering irons, must be properly ground.

14.1.8.3. To reduce the amount of static electricity generated, do not conduct assembly and other work under dry conditions.

14.1.8.4. The LCD Module is coated with a film to protect the display surface. Be care when peeling off this protective film since static electricity may be generated.

14.2 Storage Precautions

14.2.1. When storing the LCD modules, avoid exposure to direct sunlight or to the light of fluorescent lamps.

14.2.2. The LCD modules should be stored under the storage temperature range. If the LCD modules will be stored for a long time, the recommend condition is:

Temperature: 0°C ~ 40°C, Relatively humidity: ≤80%

14.2.3. The LCD modules should be stored in the room without acid, alkali and harmful gas.

14.3 Transportation Precautions

The LCD modules should be no falling and violent shocking during transportation, and also should avoid excessive press, water, damp and sunshine.