

**MAXIM****45MHz to 650MHz, Integrated IF  
VCOs with Differential Output****MAX2605-MAX2609****General Description**

The MAX2605–MAX2609 are compact, high-performance intermediate-frequency (IF) voltage-controlled oscillators (VCOs) designed specifically for demanding portable wireless communication systems. They combine monolithic construction with low-noise, low-power operation in a tiny 6-pin SOT23 package.

These low-noise VCOs feature an on-chip varactor and feedback capacitors that eliminate the need for external tuning elements, making the MAX2605–MAX2609 ideal for portable systems. Only an external inductor is required to set the oscillation frequency. In addition, an integrated differential output buffer is provided for driving a mixer or prescaler. The buffer output is capable of supplying up to -8dBm (differential) with a simple power match. It also provides isolation from load impedance variations.

The MAX2605–MAX2609 operate from a single +2.7V to +5.5V supply and offer low current consumption. These IF oscillators can cover the 45MHz to 650MHz frequency range.

**Applications**

Cellular and PCS Mobile Phones  
2.4GHz ISM Band  
902MHz to 928MHz ISM Band  
Land Mobile Radio  
GPS Receivers  
General-Purpose IF Oscillators

**Selector Guide**

PART	FREQUENCY RANGE (MHz)	SUPPLY CURRENT (mA)	PHASE NOISE (dBc/Hz)
MAX2605	45 to 70	1.9	-117
MAX2606	70 to 150	2.1	-112
MAX2607	150 to 300	2.1	-107
MAX2608	300 to 500	2.7	-100
MAX2609	500 to 650	3.6	-93

**Features**

- ◆ Small Size
- ◆ Integrated Varactor for Tuning
- ◆ Low Phase Noise
- ◆ Wide Application Frequency Range
- ◆ Differential or Single-Ended Outputs
- ◆ Single +2.7V to +5.5V Supply
- ◆ Ultra-Small SOT23-6 Package
- ◆ On-Chip Temperature-Stable Bias
- ◆ Low-Current Operation

**Ordering Information**

PART	TEMP. RANGE	PIN-PACKAGE	TOP MARK
MAX2605EUT-T	-40°C to +85°C	6 SOT23-6	AABB
MAX2606EUT-T	-40°C to +85°C	6 SOT23-6	AABC
MAX2607EUT-T	-40°C to +85°C	6 SOT23-6	AABD
MAX2608EUT-T	-40°C to +85°C	6 SOT23-6	AABE
MAX2609EUT-T	-40°C to +85°C	6 SOT23-6	AABF

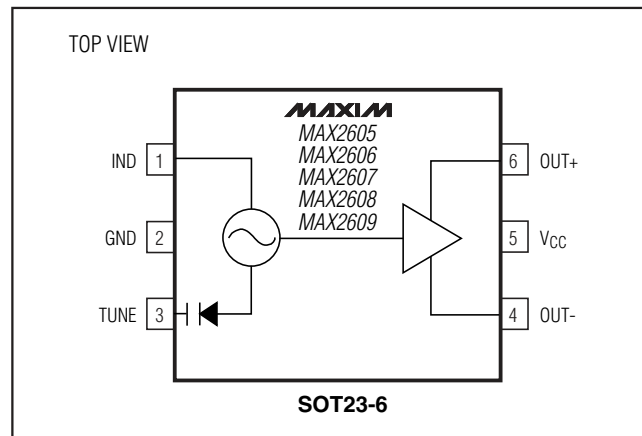
**Pin Configuration/  
Functional Diagram****MAXIM**

Maxim Integrated Products 1

**For pricing, delivery, and ordering information, please contact Maxim/Dallas Direct! at 1-888-629-4642, or visit Maxim's website at [www.maxim-ic.com](http://www.maxim-ic.com).**

# 45MHz to 650MHz, Integrated IF VCOs with Differential Output

## ABSOLUTE MAXIMUM RATINGS

V <sub>CC</sub> to GND .....	-0.3V to +6V	Operating Temperature Range .....	-40°C to +85°C
IND to GND .....	-0.6V to (V <sub>CC</sub> + 0.3V)	Junction Temperature .....	+150°C
TUNE to GND .....	-0.3V to (V <sub>CC</sub> + 0.3V)	Storage Temperature Range .....	-65°C to +150°C
OUT+, OUT- to GND .....	-0.3V to (V <sub>CC</sub> + 0.6V)	Lead Temperature (soldering, 10s) .....	+300°C
Continuous Power Dissipation (T <sub>A</sub> = +85°C)			
6-Pin SOT23 (derate 8.7mW/°C above +70°C) .....	696mW		

Stresses beyond those listed under "Absolute Maximum Ratings" may cause permanent damage to the device. These are stress ratings only, and functional operation of the device at these or any other conditions beyond those indicated in the operational sections of the specifications is not implied. Exposure to absolute maximum rating conditions for extended periods may affect device reliability.

## DC ELECTRICAL CHARACTERISTICS

(V<sub>CC</sub> = +2.7V to +5.5V, V<sub>TUNE</sub> = 0.4V to 2.4V, T<sub>A</sub> = -40°C to +85°C, unless otherwise noted. Typical values are at V<sub>CC</sub> = +2.75V, V<sub>TUNE</sub> = 1.5V, and T<sub>A</sub> = +25°C.) (Note1)

PARAMETER	CONDITIONS		MIN	TYP	MAX	UNITS
Supply Voltage			2.7		5.5	V
Supply Current (Note 2)	MAX2605	T <sub>A</sub> = +25°C		1.9	2.6	mA
		T <sub>A</sub> = -40°C to +85°C			2.8	
	MAX2606	T <sub>A</sub> = +25°C		2.1	2.7	
		T <sub>A</sub> = -40°C to +85°C			3.0	
	MAX2607	T <sub>A</sub> = +25°C		2.1	3.2	
		T <sub>A</sub> = -40°C to +85°C			3.5	
	MAX2608	T <sub>A</sub> = +25°C		2.7	4.4	
		T <sub>A</sub> = -40°C to +85°C			5.5	
	MAX2609	T <sub>A</sub> = +25°C		3.6	6.8	
		T <sub>A</sub> = -40°C to +85°C			7.5	
DC Output Current (Note 3)	OUT+ plus OUT-		0.5	1.0	1.5	mA
TUNE Input Current				0.03		nA

# 45MHz to 650MHz, Integrated IF VCOs with Differential Output

MAX2605-MAX2609

## AC ELECTRICAL CHARACTERISTICS

(MAX2605-MAX2609 EV kits,  $V_{CC} = +2.7V$  to  $+5.5V$ ,  $V_{TUNE} = 0.4V$  to  $2.4V$ ,  $T_A = -40^{\circ}C$  to  $+85^{\circ}C$ , unless otherwise noted. Typical values are at  $V_{CC} = +2.75V$ ,  $V_{TUNE} = 1.5V$ , and  $T_A = +25^{\circ}C$ .) (Note 1)

PARAMETER	CONDITIONS		MIN	TYP	MAX	UNITS		
Oscillator Nominal Frequency Range (Note 4)	MAX2605		45		70	MHz		
	MAX2606		70		150			
	MAX2607		150		300			
	MAX2608		300		500			
	MAX2609		500		650			
Guaranteed Frequency Limits (relative to nominal) (Note 5)	MAX2605	$T_A = +25^{\circ}C$	-4.1		+3.2	%		
		$T_A = -40^{\circ}C$ to $+85^{\circ}C$	-2.25		+2.25			
	MAX2606	$T_A = +25^{\circ}C$	-4.4		+3.4			
		$T_A = -40^{\circ}C$ to $+85^{\circ}C$	-2.5		+2.5			
	MAX2607	$T_A = +25^{\circ}C$	-4.6		+3.6			
		$T_A = -40^{\circ}C$ to $+85^{\circ}C$	-2.75		+2.75			
	MAX2608	$T_A = +25^{\circ}C$	-4.7		+3.6			
		$T_A = -40^{\circ}C$ to $+85^{\circ}C$	-2.8		+2.8			
	MAX2609	$T_A = +25^{\circ}C$	-5.0		+3.8			
		$T_A = -40^{\circ}C$ to $+85^{\circ}C$	-3.0		+3.0			
	Peak Tuning Gain	$V_{TUNE} = 0.4V$ to $0.6V$ step (Note 6)			14.5			%/V
	Single-Ended Output Power (Note 7)				-10			dBm
Phase Noise (Note 8)	$f_{OFFSET} = 100kHz$	MAX2605, $Q_L \geq 35$		-117		dBc/Hz		
		MAX2606, $Q_L \geq 35$		-112				
		MAX2607, $Q_L \geq 35$		-107				
		MAX2608, $Q_L \geq 40$		-100				
		MAX2609, $Q_L \geq 40$		-93				

# 45MHz to 650MHz, Integrated IF VCOs with Differential Output

## AC ELECTRICAL CHARACTERISTICS (continued)

(MAX2605-MAX2609 EV kits,  $V_{CC} = +2.7V$  to  $+5.5V$ ,  $V_{TUNE} = 0.4V$  to  $2.4V$ ,  $T_A = -40^{\circ}C$  to  $+85^{\circ}C$ , unless otherwise noted. Typical values are at  $V_{CC} = +2.75V$ ,  $V_{TUNE} = 1.5V$ , and  $T_A = +25^{\circ}C$ .) (Note 1)

PARAMETER	CONDITIONS	MIN	TYP	MAX	UNITS
Even-Order Harmonics	Differential, $R_L = 50\Omega$ each side		-30		dBc
Supply Pushing (Note 9)	MAX2605		60		kHz/V
	MAX2606		120		
	MAX2607		220		
	MAX2608		480		
	MAX2609		720		

**Note 1:** Production tested at  $T_A = +25^{\circ}C$ . Maximum and minimum over temperature limits are guaranteed by design and characterization.

**Note 2:** Supply current is measured while the part is oscillating and inductor  $Q \geq Q_{MIN}$ . For MAX2605/MAX2606/MAX2607,  $Q_{MIN} = 35$ ; for MAX2608/MAX2609,  $Q_{MIN} = 40$ .

**Note 3:** The DC output current is the total available output signal current.

**Note 4:** Application range of the part is achieved using external inductance as specified in Figures 1-5 and shown in Figure 6. The internal varactors support center frequencies of 45MHz to 650MHz. The center frequency is defined by the value of the external inductor element,  $L_F$ . The application frequency limits are guaranteed by design and characterization.

**Note 5:** The guaranteed (tested) limits  $f_{MIN}$  and  $f_{MAX}$  are measured at  $V_{TUNE} = 0.4V$  and  $V_{TUNE} = 2.4V$ , respectively. Passing requirements are:  $f \leq f_{MIN}$  at  $V_{TUNE} = 0.4$  and  $f \geq f_{MAX}$  at  $V_{TUNE} = 2.4V$ . The nominal frequency of oscillation is defined by the inductor.

**Note 6:** Describes peak tuning gain, which occurs at  $V_{TUNE} = 0.4V$ .

**Note 7:** Measurement at OUT+ or OUT- matched for optimum power transfer into  $50\Omega$  load near the center of the operating frequency range.

**Note 8:** The phase-noise specifications listed apply to the typical operating circuit shown in Figure 6. Apply over the entire operating frequency range of the MAX2605-MAX2609.

**Note 9:** Supply pushing is measured with  $V_{CC}$  stepped from  $+2.7V$  to  $+3.2V$ .

## Typical Operating Characteristics

(MAX260\_ EV kit,  $V_{CC} = +2.75V$ ,  $V_{TUNE} = 1.4V$ ,  $T_A = +25^{\circ}C$ , unless otherwise noted.)

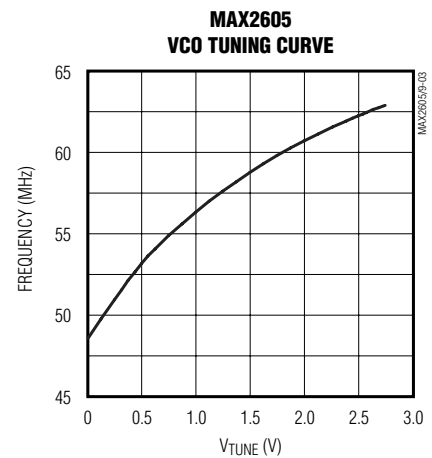
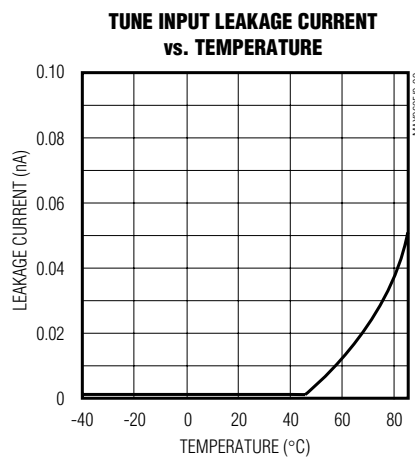
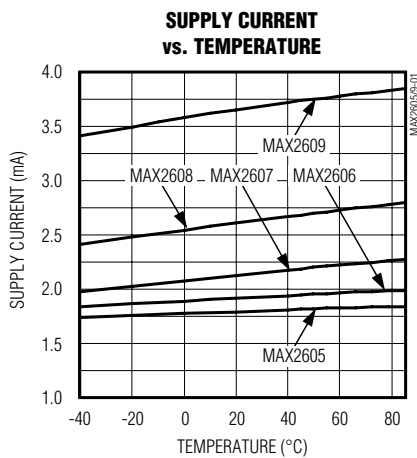

# 45MHz to 650MHz, Integrated IF VCOs with Differential Output

## Typical Operating Characteristics (continued)

(MAX260\_EV kit,  $V_{CC} = +2.75V$ ,  $V_{TUNE} = 1.4V$ ,  $T_A = +25^{\circ}C$ , unless otherwise noted.)

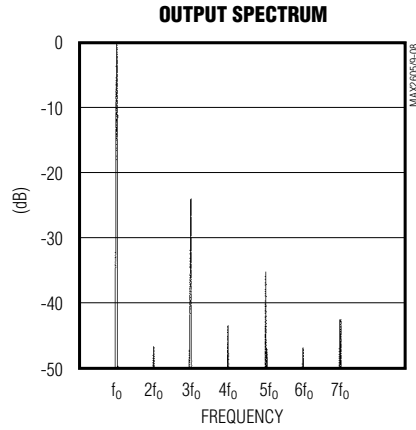
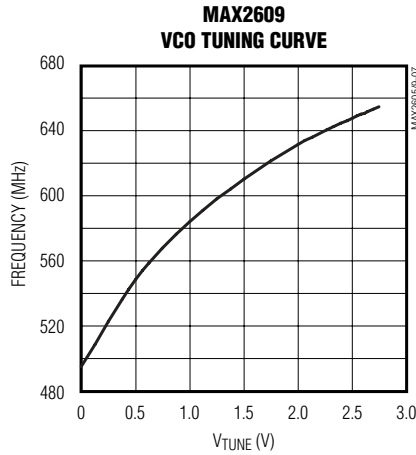
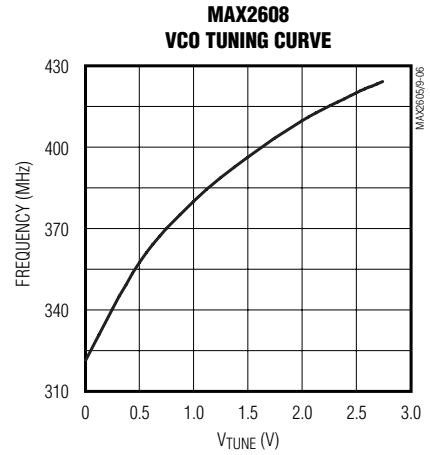
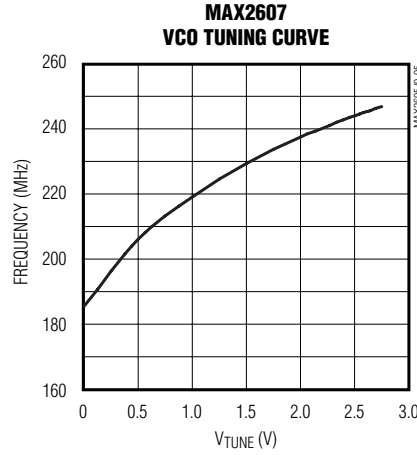
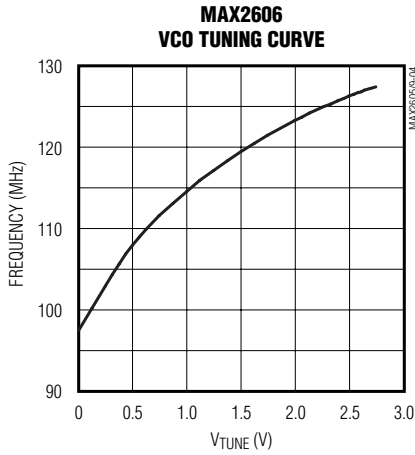

**MAX2605-MAX2609**

## Pin Description

PIN	NAME	FUNCTION
1	IND	Tuning Inductor Port. Connect an inductor from IND to GND to set VCO center frequency (see <i>Oscillation Frequency</i> ).
2	GND	Ground. Connect to the ground plane with a low-inductance path.
3	TUNE	Voltage-Control Input for Frequency Tuning. Input voltage range from +0.4V to +2.4V.
4	OUT-	High-Impedance Open-Collector Output. An external pull-up resistor or inductor to $V_{CC}$ is required. Output power is dependent on external load impedance. OUT- is complementary to OUT+.
5	$V_{CC}$	Supply Voltage Connection. Connect an external bypass capacitor to ground for low noise and low spurious-output content. See <i>Layout Issues</i> for more details.
6	OUT+	High-Impedance Open-Collector Output. An external pull-up resistor or inductor to $V_{CC}$ is required. Output power is dependent on external load impedance. OUT+ is complementary to OUT-.

# 45MHz to 650MHz, Integrated IF VCOs with Differential Output

## Detailed Description

The MAX2605–MAX2609 are low-noise VCOs designed for fixed/single-frequency IF applications. The core oscillator circuit is based on the well-known Colpitts topology. The varactor and feedback capacitors are integrated on-chip so that only an external inductor is required to establish the frequency of oscillation and produce a properly operating VCO. The tuning range, biasing, startup, etc., are all managed within the IC. This highly integrated design dramatically simplifies the parts' application.

The tuning range is wide enough so that, with the use of  $\pm 2\%$  tolerance inductors, no board-level adjustments to the oscillation frequency are necessary. Once the correct inductor value is chosen, the VCO is guaranteed always to tune to the desired operating frequency. In addition, with the use of inductors of moderate Q (35 to 40), the VCO achieves excellent phase-noise performance.

## Applications Information

### Desired Oscillation Frequency

The desired VCO operating frequency is set by the value of the external inductance,  $L_F$ . Figures 1–5 show the inductance value  $L_F$  required to achieve the desired oscillation frequency. The inductor value can be taken directly from these figures. Inductance must be selected accurately to ensure proper operation over all conditions.

### Inductor Implementation

The inductance value required for the desired operating frequency may not necessarily coincide with a standard-value SMT inductor, which typically increases size in  $\sim 1.2x$  steps. In such cases, the inductance must be constructed from two inductors,  $L_{F1}$  and  $L_{F2}$ , in order to achieve the desired inductance value. Choose  $L_{F1}$  to be a standard-value inductor with a value just less than

that required for  $L_F$ . Choose  $L_{F2}$  to be a standard-value inductor with a value just less than  $(L_F - L_{F1})$ .  $L_{F1}$  should adhere to the minimum Q requirements, but  $L_{F2}$  may be implemented as a lower-cost, lower-Q, thin-film SMT inductor. Its lower Q has only a small impact on the overall Q of the total inductance because it is  $< 20\%$  of the total inductance. However, the overall Q of  $L_{F1}$  and  $L_{F2}$  must be greater than the minimum inductor Q (Table 1).

It is also permissible to use PC board traces to provide a small amount of inductance, thereby adjusting the total inductance value. On the MAX2608/MAX2609, the inductance values for  $L_{F2}$  are sometimes more exactly implemented as a PC board trace (shorted to GND), rather than an SMT inductor. When designing  $L_F$  with two inductors, use the simple model in Figure 7 to calculate  $X_L$  and  $LEQ$ .

The  $L_F$  in Figures 1–5 represents an equivalent inductance as seen by pin 1 (IND). The equivalent inductance corresponds to the inductive reactance connected to IND at the desired oscillation frequency ( $f_{NOMINAL}$ ).

$$LEQ = X_L / (2\pi f_{NOMINAL}) \text{ as seen in Figure 8}$$

Design  $LEQ = L_F$  at the desired  $f_{NOMINAL}$ . The MAX2605–MAX2609 are designed to tolerate approximately 0.5pF of external parasitic capacitance at IND. This parasitic capacitance arises from the pad capacitance at the device pin and pads for the inductor. Additional shunt capacitance is not recommended because it degrades the tuning range.

### Bypass Capacitor on TUNE

The MAX2605–MAX2609's oscillator design uses a variant of the Colpitts topology, where DC bias for the varactor is applied via a DC voltage on TUNE and a ground connection through the external inductor  $L_F$ . TUNE must also have a high-frequency AC ground for

Table 1. External Inductor  $L_F$  Range

PART	FREQUENCY RANGE (MHz)	INDUCTANCE RANGE (nH)	MIN INDUCTOR Q
MAX2605	45 to 70	$680 \leq L_F \leq 2200$	35
MAX2606	70 to 150	$150 \leq L_F \leq 820$	35
MAX2607	150 to 300	$39 \leq L_F \leq 180$	35
MAX2608	300 to 500	$10 \leq L_F \leq 47$	40
MAX2609	500 to 650	$3.9 \leq L_F \leq 15$	40

Table 2. CBYPASS Values

DEVICE	CBYPASS
MAX2605	$\geq 820$ pF
MAX2606	$\geq 680$ pF
MAX2607	$\geq 330$ pF
MAX2608	$\geq 100$ pF
MAX2609	$\geq 39$ pF

# 45MHz to 650MHz, Integrated IF VCOs with Differential Output

MAX2605-MAX2609

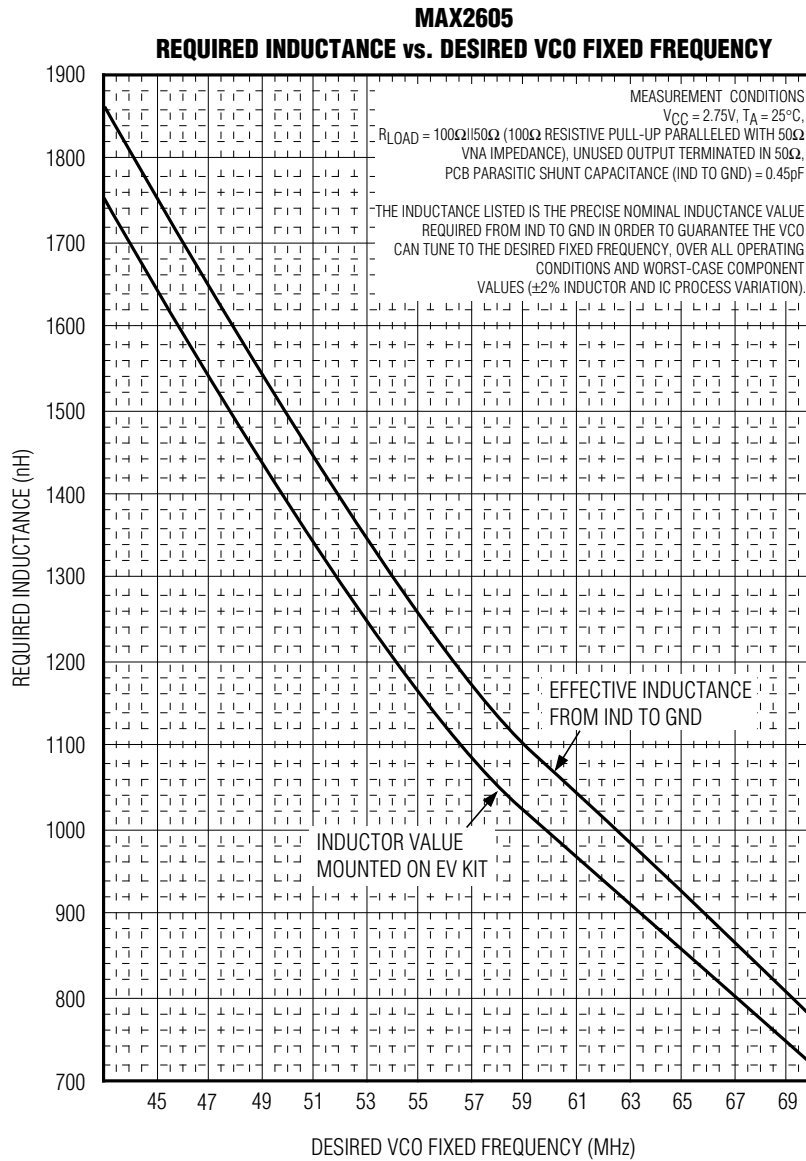

Figure 1. MAX2605 Required Inductance vs. Desired VCO Fixed Frequency

# 45MHz to 650MHz, Integrated IF VCOs with Differential Output

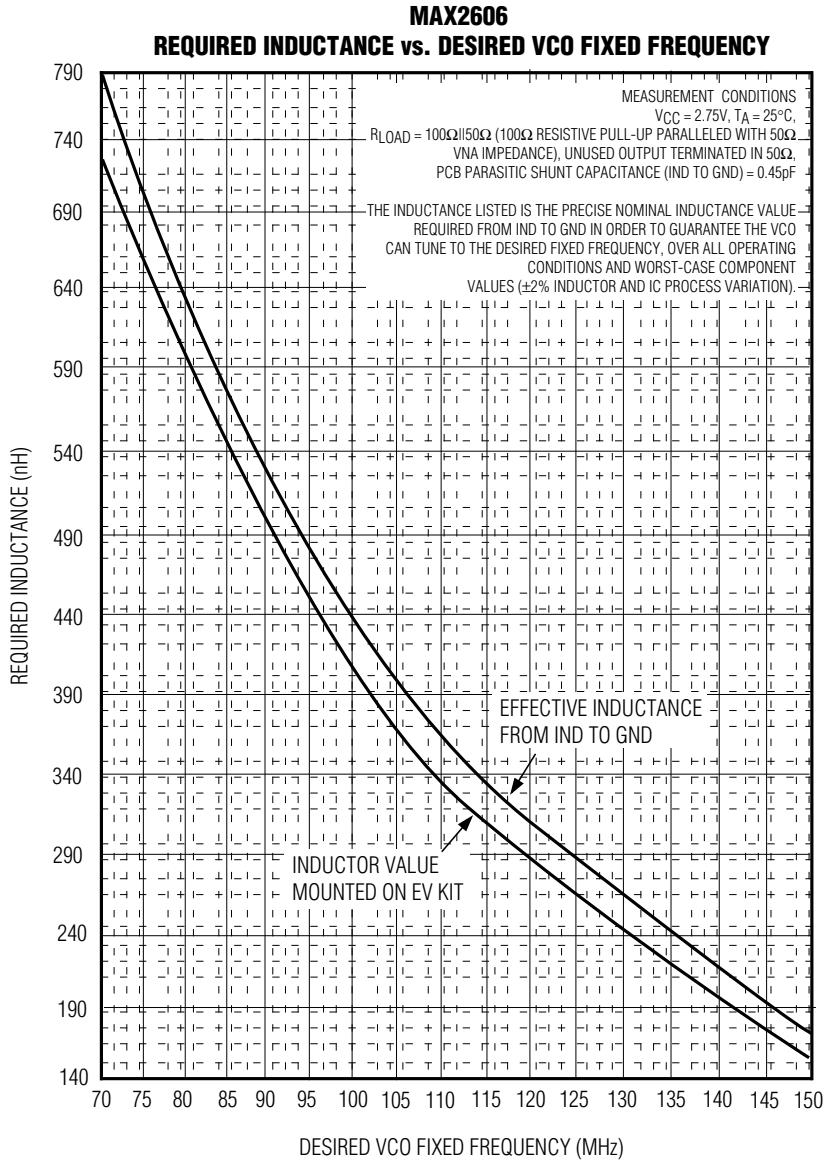

Figure 2. MAX2606 Required Inductance vs. Desired VCO Fixed Frequency



# 45MHz to 650MHz, Integrated IF VCOs with Differential Output

MAX2605-MAX2609

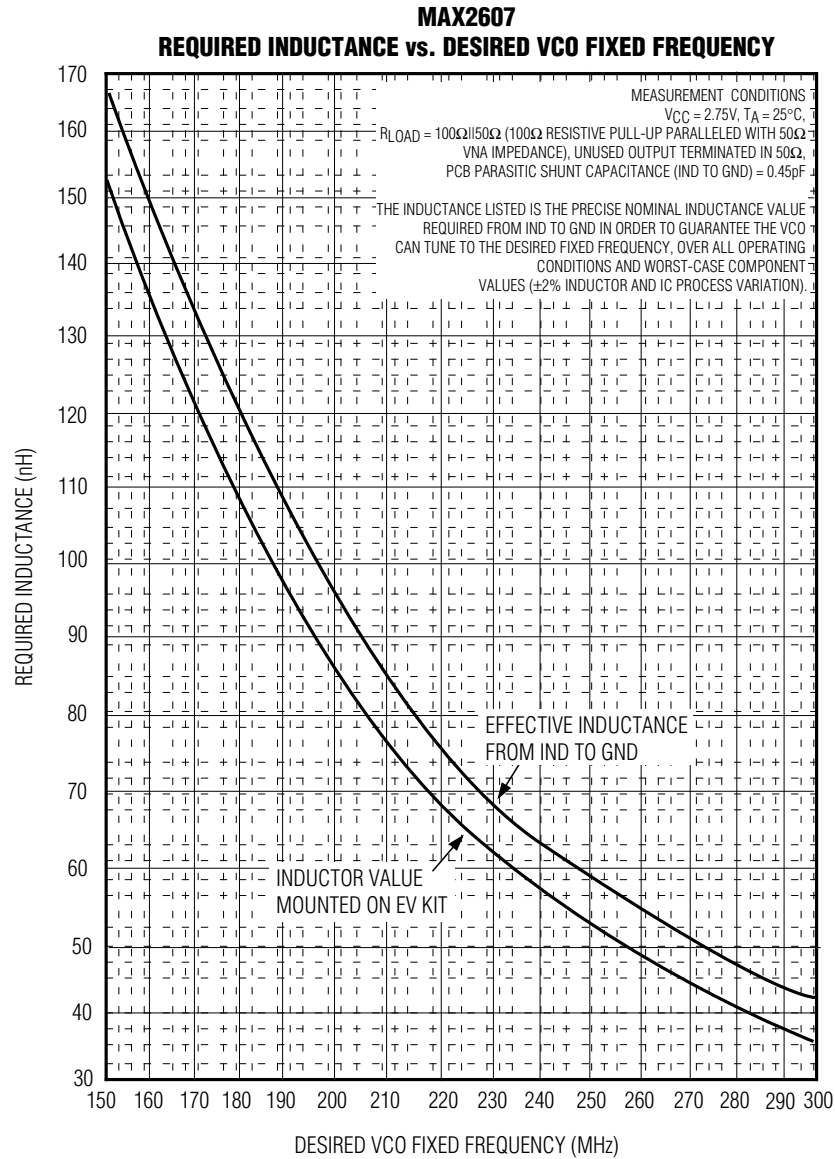

Figure 3. MAX2607 Required Inductance vs. Desired VCO Fixed Frequency

# 45MHz to 650MHz, Integrated IF VCOs with Differential Output

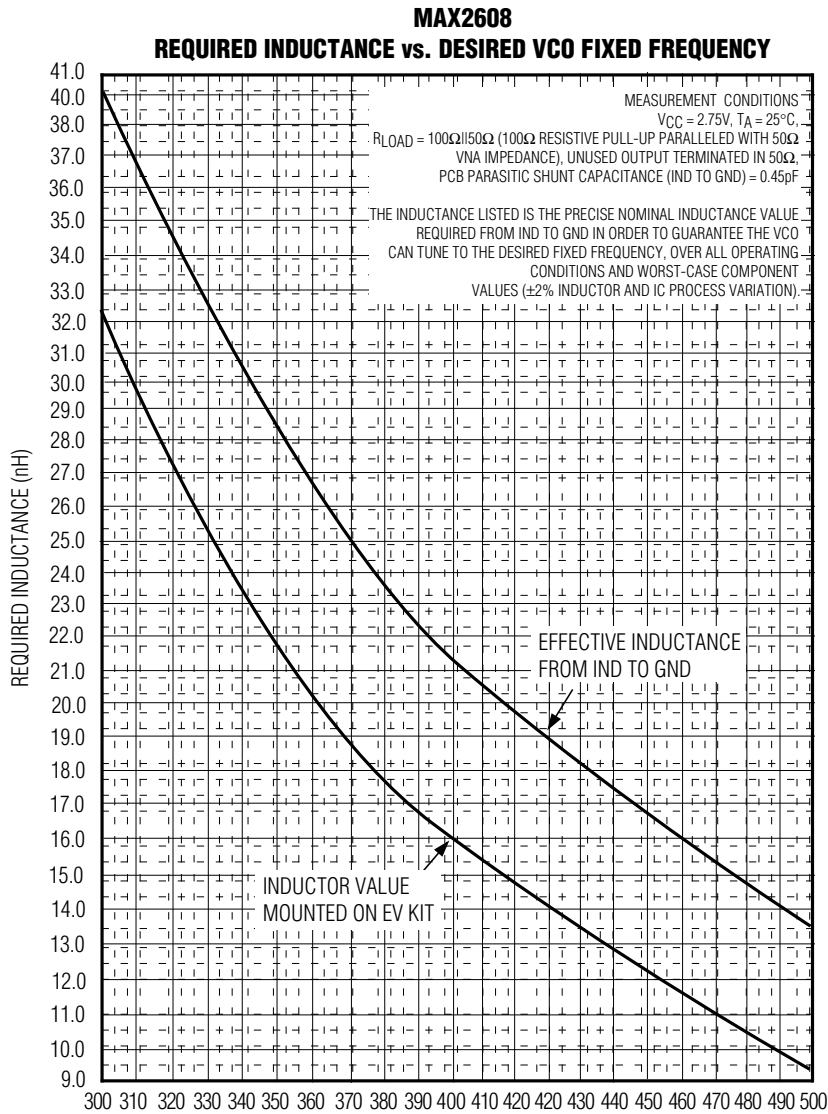

Figure 4. MAX2608 Required Inductance vs. Desired VCO Fixed Frequency

# 45MHz to 650MHz, Integrated IF VCOs with Differential Output

MAX2605-MAX2609

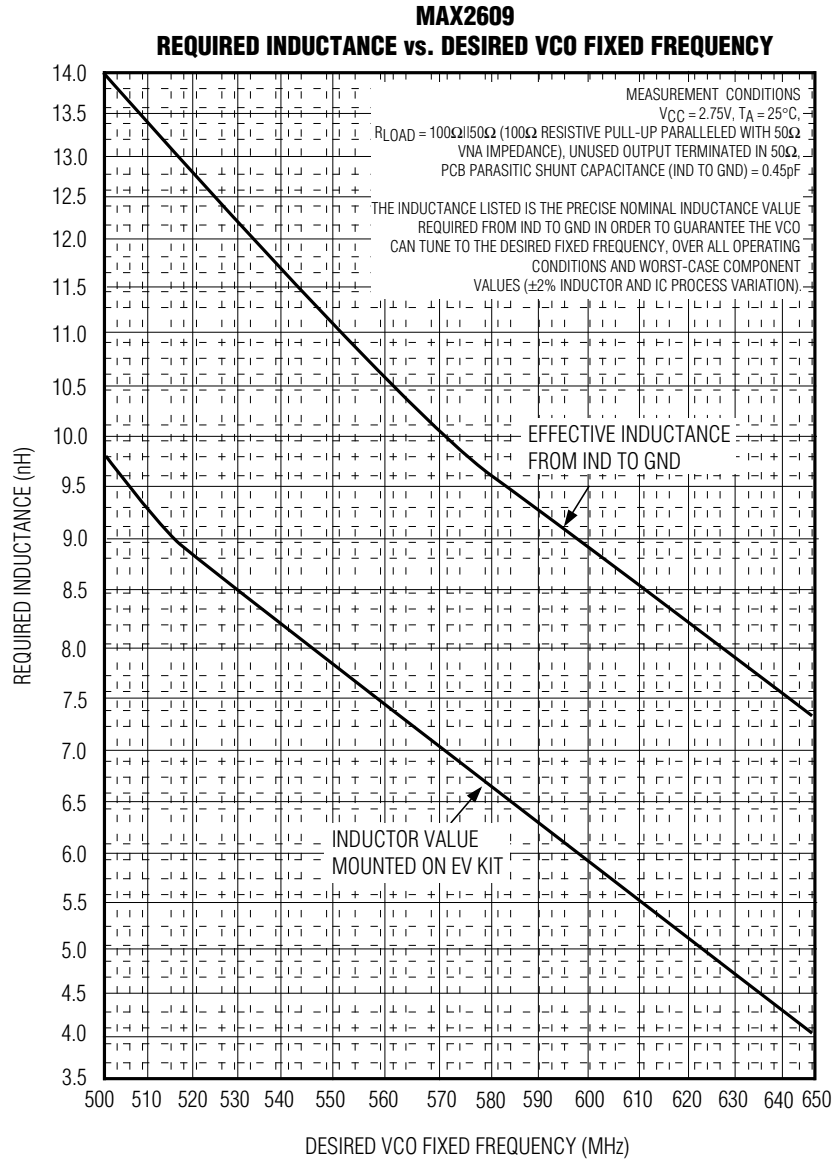

Figure 5. MAX2609 Required Inductance vs. Desired VCO Fixed Frequency

## 45MHz to 650MHz, Integrated IF VCOs with Differential Output

the cathode of the varactor. This is accomplished through the use of a simple bypass capacitor connected from TUNE to ground. The value of this capacitor should be greater than or equal to the values listed in Table 2.

This capacitor provides an AC “short” to ground for the internal node of the varactor. It is acceptable to select the next-largest standard-value capacitor. Use a capacitor with a low-loss dielectric such as NPO; X7R-based capacitors are **not** suitable. Omitting this capacitor would affect the tuning characteristics of the MAX2605–MAX2609. Proper operation of the VCOs requires the use of this bypass capacitor.

The MAX2605–MAX2609 VCO is designed to tune over the full tuning range with a voltage range of 0.4V to 2.4V applied to TUNE. This voltage typically originates from the output of the phase-locked (PLL) loop filter.

### Output Interface

The MAX2605–MAX2609 VCO includes a differential output amplifier after the oscillator core. The amplifier stage provides valuable isolation and offers a flexible interface to the IF stages, such as a mixer and PLL prescaler. The output can be taken single ended or differentially; however, the maximum output power and lowest harmonic output are achieved in the differential output mode.

Both outputs (OUT- and OUT+) are open-collector types and require a pull-up element to VCC; this can be either resistive or inductive. A resistor pull-up is the most straightforward method of interfacing to the output, and works well in applications that operate at lower frequencies or only require a modest voltage swing.

In Figure 6, Z1 and Z2 are 1kΩ pull-up resistors that are connected from OUT+ and OUT- to VCC, respectively. These resistors provide DC bias for the output amplifier and are the maximum value permitted with compliance to the output voltage swing limits. In addition, the 1kΩ resistors maximize the swing at the load. DC-blocking capacitors are connected from OUT- and OUT+ to the load. If the load driven is primarily resistive and the VCO operating frequency is below the -3dB bandwidth of the output network, then the peak-to-peak differential signal amplitude is approximately:

$$V_{\text{OUT-p}}(\text{diff}) = 2 \times 1\text{mA} \left( \frac{1\text{k}\Omega \times R_{\text{LOAD}}}{1\text{k}\Omega + R_{\text{LOAD}}} \right)$$

To optimize the output voltage swing or the output power, use a reactive power match. The matching network is a simple shunt-inductor series-capacitor circuit, as shown in Figure 6. The inductors are connected

from OUT- and OUT+ (in place of resistors) to VCC to provide DC bias for the output stage. The series capacitors are connected from OUT- and OUT+ to the load. The values for L<sub>MATCH</sub> (Z<sub>1</sub> and Z<sub>2</sub>) and C<sub>MATCH</sub> (C<sub>1</sub> and C<sub>2</sub>) are chosen according to the operating frequency and load impedance. As the output stage is essentially a high-speed current switch, traditional linear impedance using techniques with [S] parameters do not apply. To achieve a reactive power match, start with the component values provided in the EV kit, and adjust values experimentally.

In general, the differential output may be applied in any manner, as would conventional differential outputs. The only constraints are the need for a pull-up element to VCC and a voltage swing limit at the output pins OUT- and OUT+.

### Layout Considerations

In general, a properly designed PC board is essential to any RF/microwave circuit or system. Always use controlled impedance lines (microstrip, coplanar waveguide, etc.) on high-frequency signals. Always place decoupling capacitors as close to the VCC pin as possible. For low phase noise and spurious content, use an appropriate size decoupling capacitor. For long VCC lines, it may be necessary to add additional decoupling capacitors located further from the device. Always provide a low-inductance path to ground. Keep the GND vias as close to the device as possible. In addition, the VCO should be placed as far away from the noisy section of a larger system, such as a switching regulator or digital circuits. Use star topology to separate the ground returns.

The resonator tank circuit (L<sub>F</sub>) is critical in determining the VCO's performance. For best performance, use high-Q components and choose values carefully. To minimize the effects of parasitic elements, which degrade circuit performance, place L<sub>F</sub> and C<sub>BYP</sub> close to their respective pins. Specifically, place C<sub>BYP</sub> directly across pins 2 (GND) and 3 (TUNE).

For the higher frequency versions, consider the extra parasitic inductance and capacitance when determining the oscillation frequency. Be sure to account for the following: PC board pad capacitance at IND, PC board pad capacitance at the junction of two series inductors, series inductance of any PC board traces, and the inductance in the ground return path from the grounded side of the inductor and IC's GND pin. For best results, connect the “ground” side to the tuning inductor as close to pin 2 as possible. In addition, remove the ground plane around and under L<sub>F</sub> and C<sub>BYP</sub> to minimize the effects of parasitic capacitance.

# 45MHz to 650MHz, Integrated IF VCOs with Differential Output

**MAX2605-MAX2609**

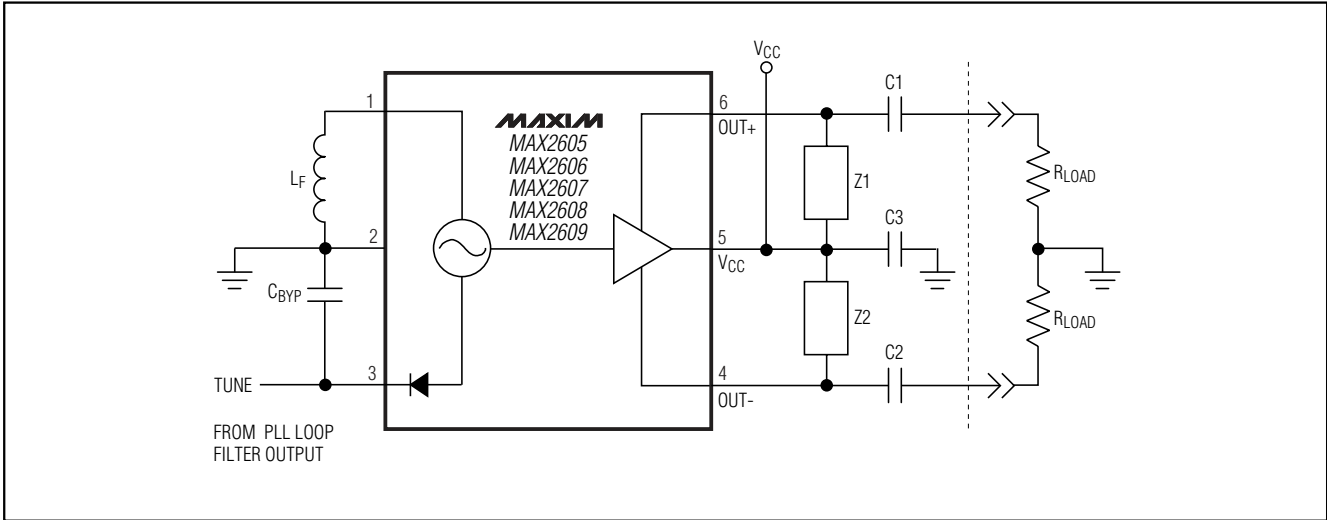

Figure 6. Typical Operating Circuit

## Chip Information

TRANSISTOR COUNT: 158

# 45MHz to 650MHz, Integrated IF VCOs with Differential Output

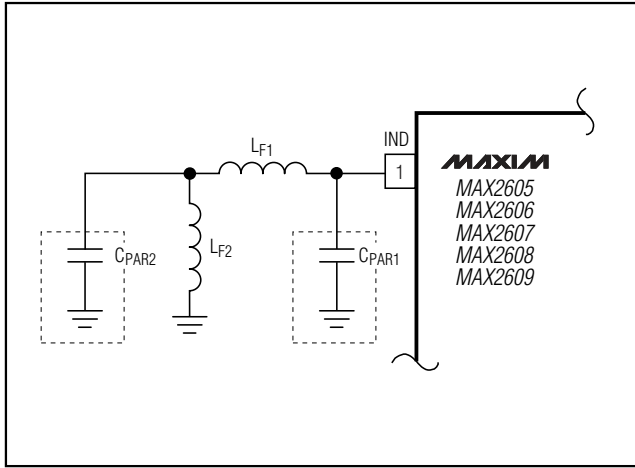

Figure 7. Simple Model of External Inductance

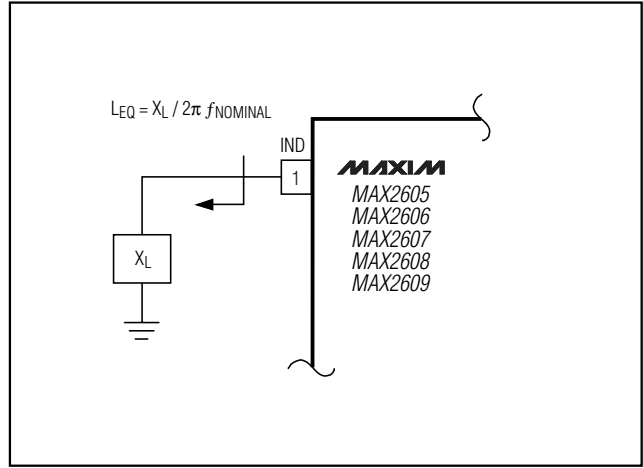

Figure 8. Inductive Reactance at Pin 1 (IND)

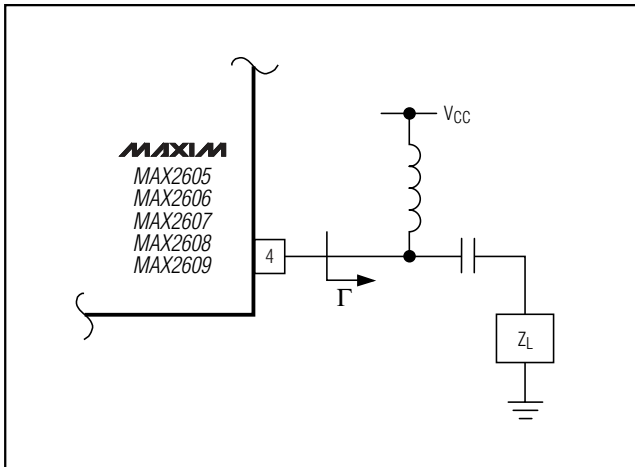

Figure 9. Output Matching Network

# 45MHz to 650MHz, Integrated IF VCOs with Differential Output

## Package Information

SEE NOTE 5  
EXAMPLE  
TOP MARK

PIN 1  
I.D. DOT  
(SEE NOTE 6)

PIN #1

0.20

DATUM 'A'

L

E1

C

SYMBOL	MIN	MAX
A	0.90	1.45
A1	0.00	0.15
A2	0.90	1.30
b	0.35	0.50
C	0.08	0.20
D	2.80	3.00
E	2.60	3.00
E1	1.50	1.75
L	0.35	0.55
e	0.95 REF	
a	0°	10°

NOTES:

1. ALL DIMENSIONS ARE IN MILLIMETERS.
2. FOOT LENGTH MEASURED AT INTERCEPT POINT BETWEEN DATUM A & LEAD SURFACE.
3. PACKAGE OUTLINE EXCLUSIVE OF MOLD FLASH & METAL BURR.
4. PACKAGE OUTLINE INCLUSIVE OF SOLDER PLATING.
5. PIN 1 IS LOWER LEFT PIN WHEN READING TOP MARK FROM LEFT TO RIGHT. (SEE EXAMPLE TOP MARK)
6. PIN 1 I.D. DOT IS 0.3 MM Ø MIN. LOCATED ABOVE PIN 1.
7. MEETS JEDEC MO178.

PROPRIETARY INFORMATION

TITLE:  
PACKAGE OUTLINE, SDT-23, 6L

APPROVAL	DOCUMENT CONTROL NO.	REV	1/1
	21-0058	E	

6LS0TEPS

Maxim cannot assume responsibility for use of any circuitry other than circuitry entirely embodied in a Maxim product. No circuit patent licenses are implied. Maxim reserves the right to change the circuitry and specifications without notice at any time.

Maxim Integrated Products, 120 San Gabriel Drive, Sunnyvale, CA 94086 408-737-7600 15