

## Displacement Sensor, Ultra Flat



### FEATURES

- Sealed
- Infinite resolution
- High integration capacity
- Durability
- Rectilinear: UFPMA type
- Circular: UFPMC type
- Material categorization: for definitions of compliance please see [www.vishay.com/doc?99912](http://www.vishay.com/doc?99912)



### LINKS TO ADDITIONAL RESOURCES



### QUICK REFERENCE DATA

Sensor type	LINEAR or ROTATIONAL, conductive plastic
Output type	Output by wires or connector
Market appliance	Industrial, avionics
Dimensions	4 mm (thickness max.)

### ELECTRICAL SPECIFICATIONS

PARAMETER	UFPMA	UFPMC
Total resistance ( $R_n$ )		4.7 k $\Omega$
Tolerance on $R_n$		$\pm 20\%$
Dissipation	$\leq 0.1$ W/cm of travel <sup>(1)</sup>	$\leq 1$ W to 70 °C
Theoretical electrical travel (TET)	20 mm to 250 mm <sup>(1)</sup>	270°
Tolerance on TET	$\pm 1$ mm	$\pm 3^\circ$
Electrical continuity travel	TET + 4 mm	310°
Linearity	$\pm 2\%$	$\pm 1.5\%$
Temperature coefficient	-300 ppm/°C $\pm$ 300 ppm/°C	
Collector / track current ( $I_c$ )	$\leq 1$ mA	
Recommended current $I_c$	$\leq 100$ $\mu$ A	
Recommended load impedance	$\geq 100 R_n$	
Output smoothness	< 0.1 % (NFC 93 255)	

#### Note

<sup>(1)</sup> See “Specific UFPMA Characteristics” table

### MECHANICAL SPECIFICATIONS

PARAMETER	UFPMA	UFPMC
Design	Flexible insulating films	Flexible insulating films on FR4 substrate
Mechanical travel	= Electrical continuity travel	= Electrical continuity travel (customer stops)
Backlash	< 0.1 mm	< 0.3°
Mounting	With double-sided adhesive on flat, clean, and dry support	
Speed displacement	$\leq 1.5$ m/s	
Drive	Force $\geq 0.3$ N	Torque $\geq 1$ N cm
Protection class (NFC 20 010)	IP 66	
Maximum alignment fault	$\pm 1$ mm	-

### PERFORMANCE

PARAMETER	UFPMA	UFPMC
Life	25M operations for TET < 200 mm	> 10M cycles
	15M operations for TET $\geq 200$ mm	
Operating temperature range	-30 °C to +80 °C	
Storage temperature range	-40 °C to +90 °C	
Support	Flat, clean, and dry	

#### Note

- Nothing stated herein shall be construed as a guarantee of quality or durability

**SAP PART NUMBERING GUIDELINES - UFPMA**

MODEL	TYPE	THEORETICAL ELECTRICAL TRAVEL (mm)	TYPE	VALUE	LINEARITY	LEADS	PACKAGING
UFPM	A = linear	060 100 150 200 250	A = aeronautic, off-road, or medical	472 = 4K7	X = ± 2 % (UFPMA)	W = wires	B = bulk

**CONNECTIONS**

3 x AWG 22 color wires length 300 mm

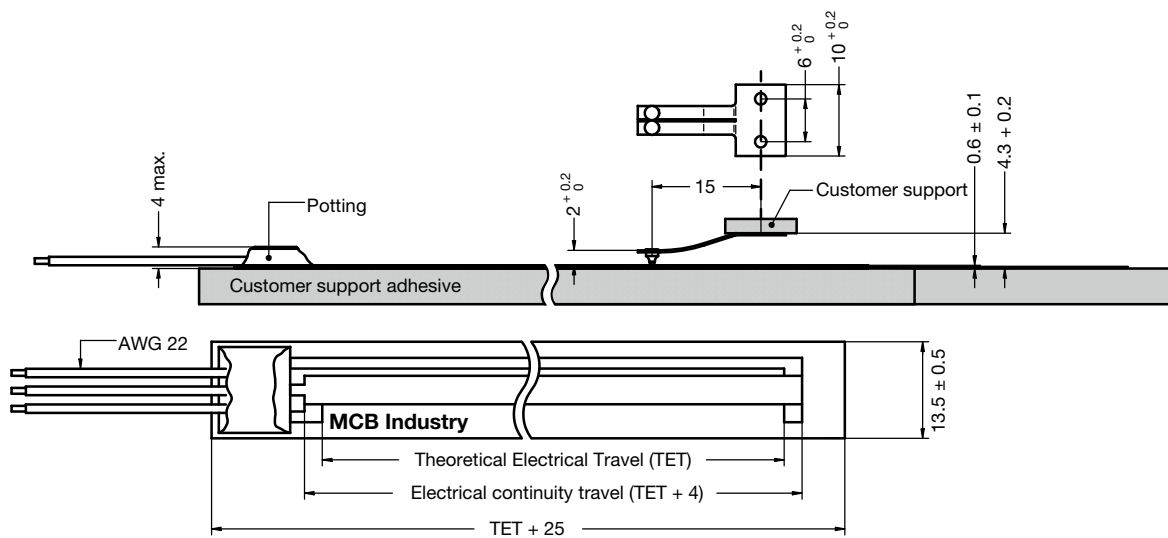
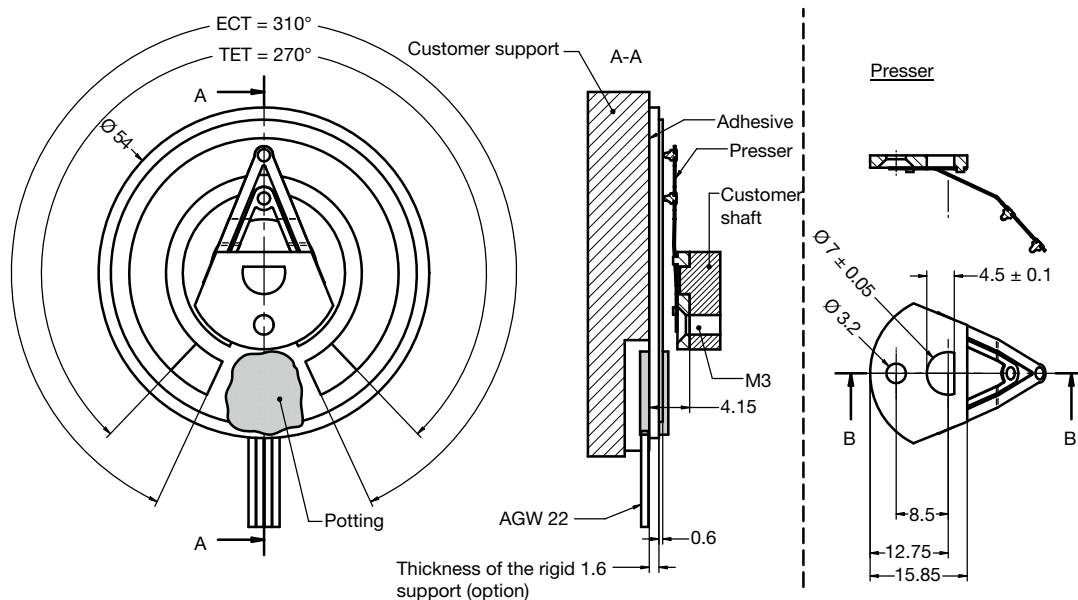
**DIMENSIONS in millimeters**
**UFPMA**

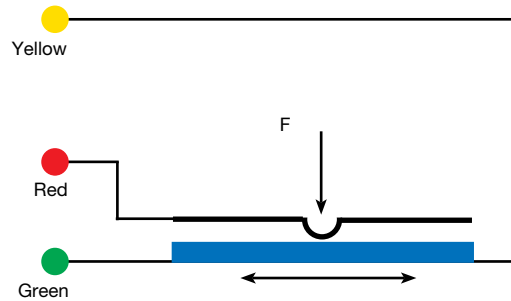
**UFPMC (ON REQUEST)**

**ELECTRICAL DIAGRAM**

The voltage varies according to the position of the presser on the deformable membrane.

**OPTIONS** (on request)

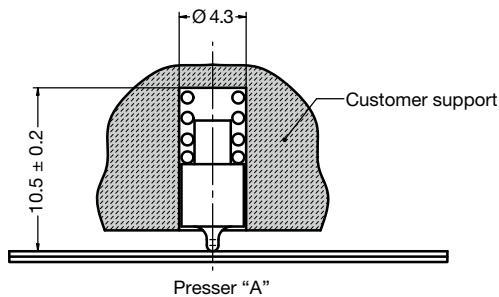
- Other presser

**SPECIFIC VERSIONS** (on request)

- Other electrical or mechanical characteristics
- Other bases
- Integration in equipment
- Other versions: outdoor design, ...
- Integration in equipment (flat flex cable, contacts, connector, ...)

<b>SPECIFIC UFPMA CHARACTERISTICS</b>			
THEORETICAL ELECTRICAL TRAVEL (TET) (mm)	DISSIPATION AT +40 °C (W)	ELECTRICAL CONTINUITY TRAVEL (ECT) (mm)	FILM LENGTH (mm)
50	≤ 0.5	54	75
100	≤ 1.0	104	125
150	≤ 1.5	154	175
200	≤ 2.0	204	225
250	≤ 2.5	254	275

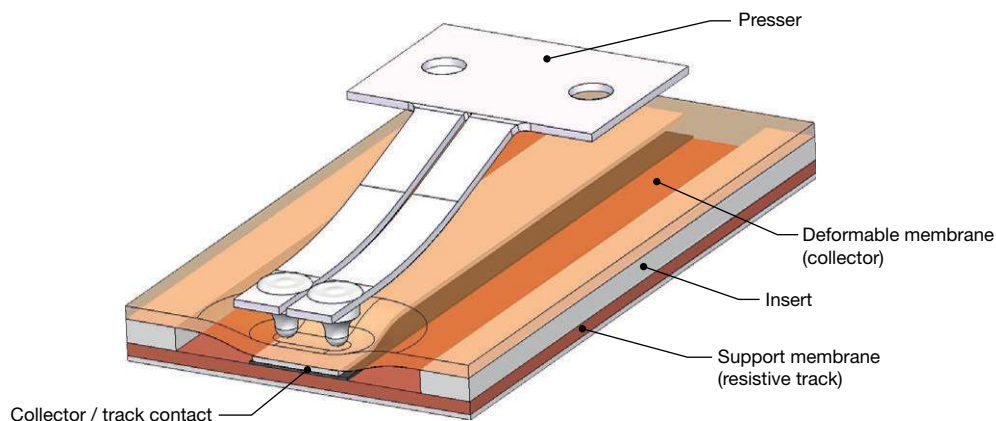
**OPERATING DESCRIPTION**



## Disclaimer

ALL PRODUCT, PRODUCT SPECIFICATIONS AND DATA ARE SUBJECT TO CHANGE WITHOUT NOTICE TO IMPROVE RELIABILITY, FUNCTION OR DESIGN OR OTHERWISE.

Vishay Intertechnology, Inc., its affiliates, agents, and employees, and all persons acting on its or their behalf (collectively, "Vishay"), disclaim any and all liability for any errors, inaccuracies or incompleteness contained in any datasheet or in any other disclosure relating to any product.

Vishay makes no warranty, representation or guarantee regarding the suitability of the products for any particular purpose or the continuing production of any product. To the maximum extent permitted by applicable law, Vishay disclaims (i) any and all liability arising out of the application or use of any product, (ii) any and all liability, including without limitation special, consequential or incidental damages, and (iii) any and all implied warranties, including warranties of fitness for particular purpose, non-infringement and merchantability.

Statements regarding the suitability of products for certain types of applications are based on Vishay's knowledge of typical requirements that are often placed on Vishay products in generic applications. Such statements are not binding statements about the suitability of products for a particular application. It is the customer's responsibility to validate that a particular product with the properties described in the product specification is suitable for use in a particular application. Parameters provided in datasheets and / or specifications may vary in different applications and performance may vary over time. All operating parameters, including typical parameters, must be validated for each customer application by the customer's technical experts. Product specifications do not expand or otherwise modify Vishay's terms and conditions of purchase, including but not limited to the warranty expressed therein.

Hyperlinks included in this datasheet may direct users to third-party websites. These links are provided as a convenience and for informational purposes only. Inclusion of these hyperlinks does not constitute an endorsement or an approval by Vishay of any of the products, services or opinions of the corporation, organization or individual associated with the third-party website. Vishay disclaims any and all liability and bears no responsibility for the accuracy, legality or content of the third-party website or for that of subsequent links.

Except as expressly indicated in writing, Vishay products are not designed for use in medical, life-saving, or life-sustaining applications or for any other application in which the failure of the Vishay product could result in personal injury or death. Customers using or selling Vishay products not expressly indicated for use in such applications do so at their own risk. Please contact authorized Vishay personnel to obtain written terms and conditions regarding products designed for such applications.

No license, express or implied, by estoppel or otherwise, to any intellectual property rights is granted by this document or by any conduct of Vishay. Product names and markings noted herein may be trademarks of their respective owners.