

**SERIES: VFK600 | DESCRIPTION: DC-DC CONVERTER**
**FEATURES**

- up to 700 W isolated output
- rugged metal enclosure with integrated heat sink
- 2:1 input range (18~36 Vdc, 36~75 Vdc)
- single output from 12~48 Vdc
- 1,500 Vdc isolation
- over current, over temperature, over voltage, and short circuit protections
- remote on/off
- N+1 current sharing
- efficiency up to 92%



MODEL	input voltage range	output voltage	output current	output power	ripple and noise <sup>1</sup>	efficiency
	(Vdc)	(Vdc)	max (A)	max (W)	max (mVp-p)	typ (%)
VFK600-D24-S12	18 ~ 36	12	50	600	120	89
VFK600-D24-S24	18 ~ 36	24	25	600	240	91
VFK600-D24-S28	18 ~ 36	28	21.5	600	280	90
VFK600-D24-S32	18 ~ 36	32	19	608	320	91
VFK600-D24-S48	18 ~ 36	48	12.5	600	480	92
VFK600-D48-S12	36 ~ 75	12	50	600	120	90
VFK600-D48-S24	36 ~ 75	24	25	600	240	91
VFK600-D48-S28	36 ~ 75	28	25	700	280	91
VFK600-D48-S32	36 ~ 75	32	19	608	320	92
VFK600-D48-S48	36 ~ 75	48	12.5	600	480	92

Notes: 1. Ripple and noise are measured at full load, 20 MHz BW with 10 $\mu$ F tantalum capacitor and 1 $\mu$ F ceramic capacitor across output

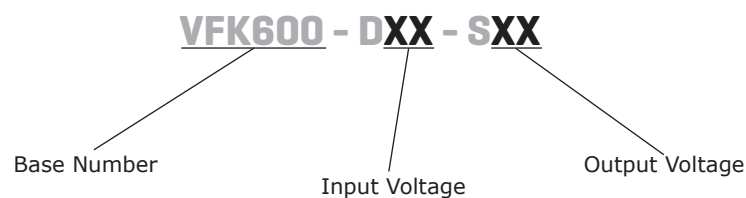
**PART NUMBER KEY**

## INPUT

parameter	conditions/description	min	typ	max	units	
operating input voltage	24 Vdc input models	18	24	36	Vdc	
	48 Vdc input models	36	48	75	Vdc	
input current	24 Vdc input models, Vin = 18 Vdc, full load		37.7		A	
	48 Vdc input models, Vin = 36 Vdc, full load		21.7		A	
under voltage shutdown	24 Vdc input	power up	16	17	18	Vdc
		power down	15	16	17	Vdc
	48 Vdc input	power up	34	35	36	Vdc
		power down	32	33	34	Vdc
over voltage shutdown	24 Vdc input	power up		38	Vdc	
		power down		40	Vdc	
	48 Vdc input	power up		77	Vdc	
		power down		80	Vdc	
CTRL <sup>1</sup>	positive logic	models ON (3.5~7.5 Vdc or open circuit)				
		models OFF (0~0.7 Vdc)				
input fuse	60 A time delay fuse for 24 Vin models, 30 A time delay fuse for 48 Vin models					
filter	pi filter					

Note: 1. Open collector refer to -Vin.

## OUTPUT

parameter	conditions/description	min	typ	max	units
maximum capacitive load	12 V output models	470		10,000	μF
	24~48 V output models	470		5,000	μF
line regulation	measured from low line to high line			±0.2	%
load regulation	measured from zero load to full load			±0.5	%
voltage accuracy				±1.5	%
load share accuracy	50~100% load		±10		%
adjustability		60		110	%
switching frequency	48 V input, 12/28/32 V output models		300		kHz
	all other models		250		kHz
transient response	25% step load change			500	μs
temperature coefficient			±0.03		%/°C

## PROTECTIONS

parameter	conditions/description	min	typ	max	units
short circuit protection	continuous				
over current protection	% nominal output current	110		150	%
over voltage protection	%Vo	115		140	%
over temperature protection	shutdown		110		°C

## SAFETY AND COMPLIANCE

parameter	conditions/description	min	typ	max	units
isolation voltage	for 1 minute: input to output; input to case; output to case	1,500			Vdc
isolation resistance		10			MΩ
RoHS	2011/65/EU (CE)				

## ENVIRONMENTAL

parameter	conditions/description	min	typ	max	units
operating temperature	see derating curves	-40		85	°C
storage temperature		-55		105	°C

## MECHANICAL

parameter	conditions/description	min	typ	max	units
dimensions	199.14 x 126.75 x 39.12 (7.84 x 4.99 x 1.54 inch)				mm
case material	steel and aluminum extrusion				
weight			1.2		kg

## MECHANICAL DRAWING

units: mm[inch]

tolerance: X.XX = ±0.5[±0.02]

X.XXX = ±0.25[±0.010]

wire range: 22~12 AWG

screw size: #6-32

PIN CONNECTIONS	
PIN	FUNCTION
1, 2	+Vin
3	REM
4	case
5, 6	-Vin
7, 8	+Vo
9	+S
10	PC
11	Trim
12	-S
13, 14	-Vo

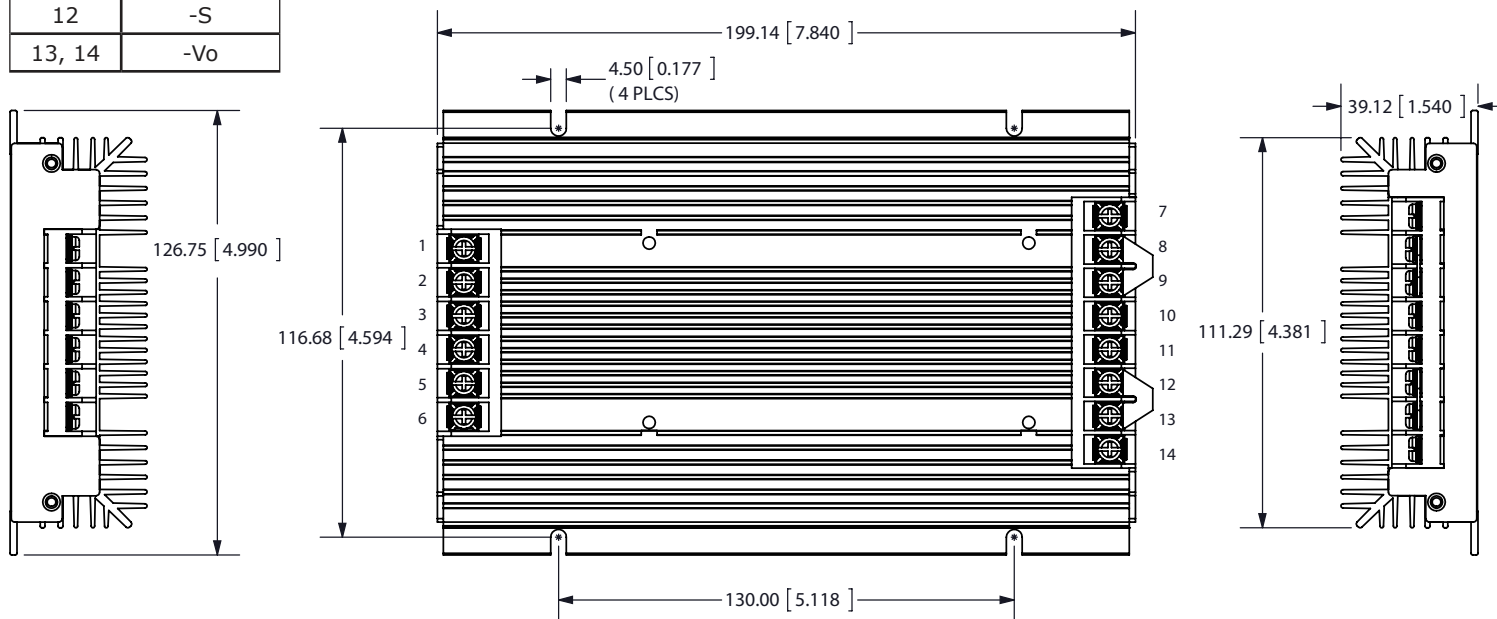
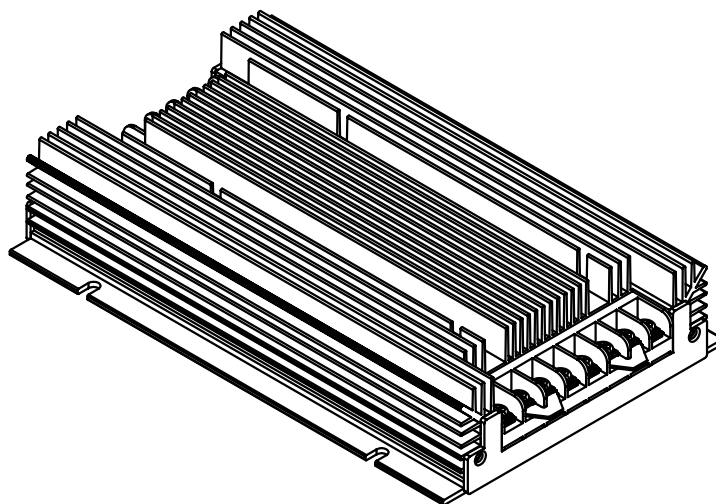

## DERATING CURVES

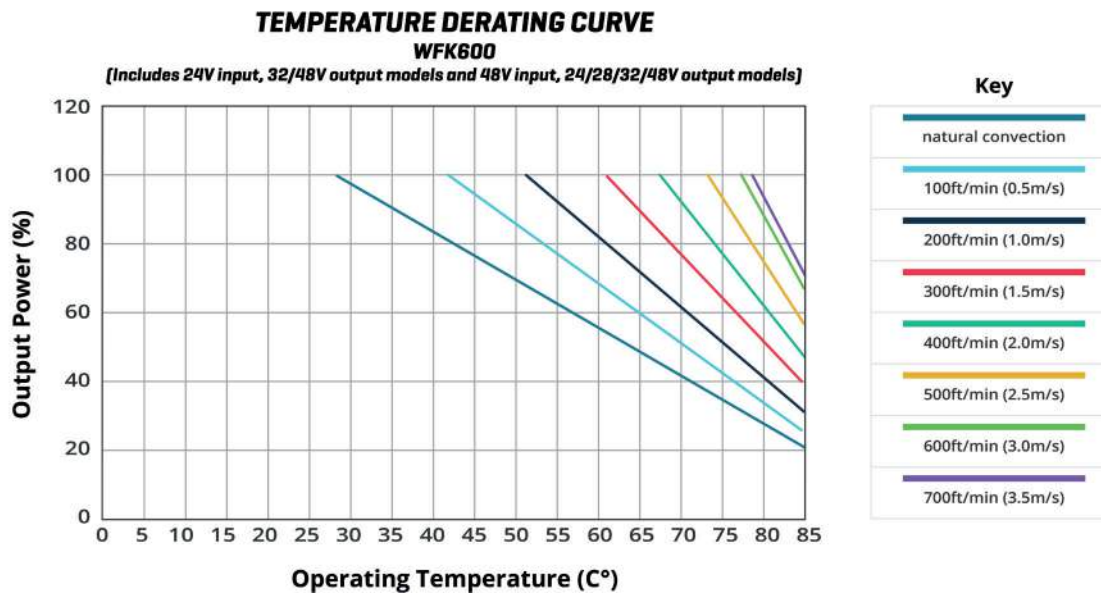
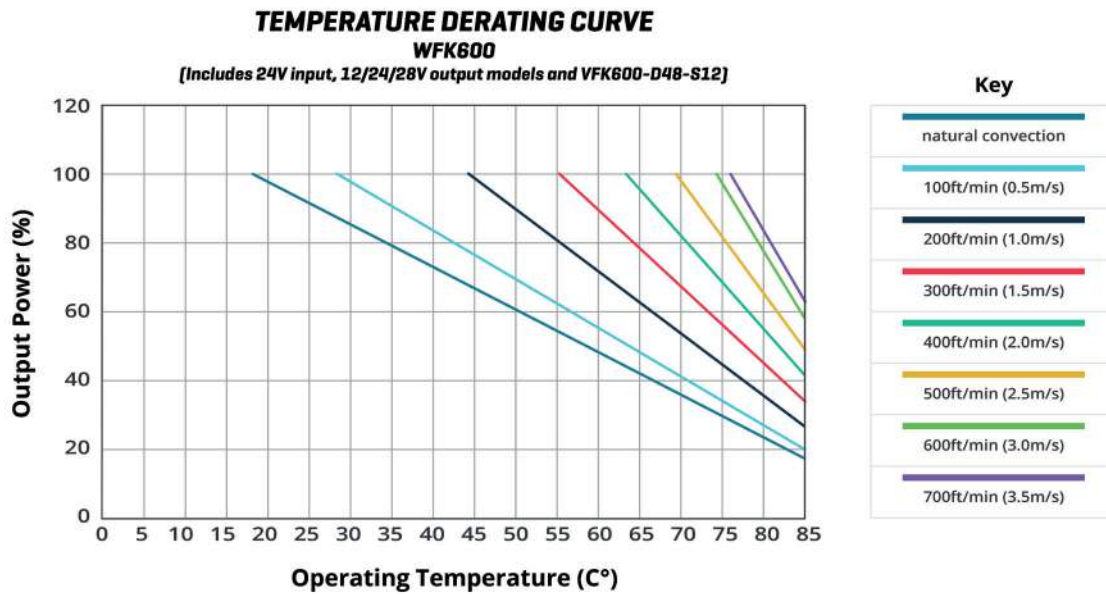

## TEST CONFIGURATION

**Figure 1**

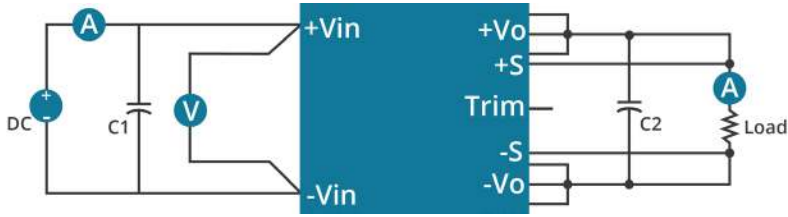

**Table 1**

Recommended External components	
C1	220 $\mu$ F/100 V
C2	470 $\mu$ F/100 V

## APPLICATION NOTES

### 1. Parallel Operation

The VFK600 series are designed for parallel operation. When in parallel the load current can be shared equally between the two modules by connecting their PC pins. The VFK600 can be setup in two different modes to achieve parallel operation. The standard parallel operation is suitable when load cannot be handled by a single unit, whereas the N+1 redundant operation is suitable for loads when backup power is required.

#### STANDARD PARALLEL CONNECTION

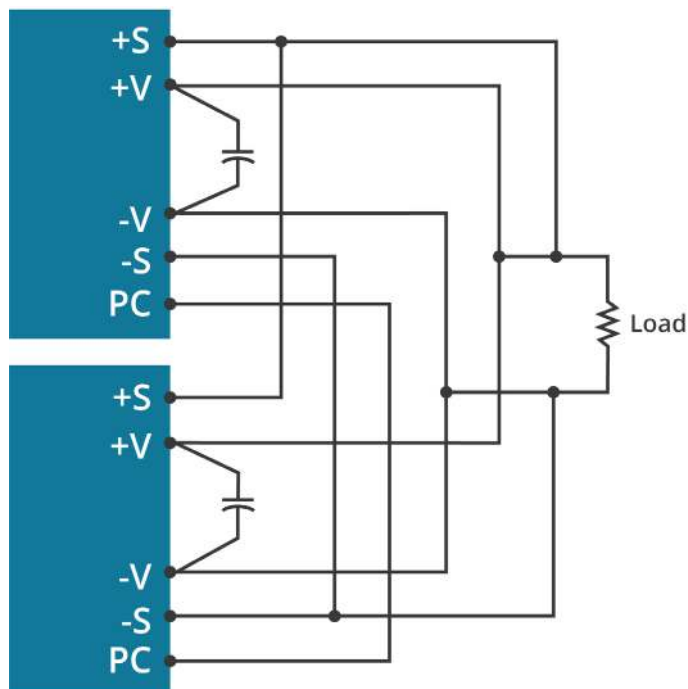

#### PARALLEL CONNECTION WITH PROGRAMMED AND ADJUSTABLE OUTPUT

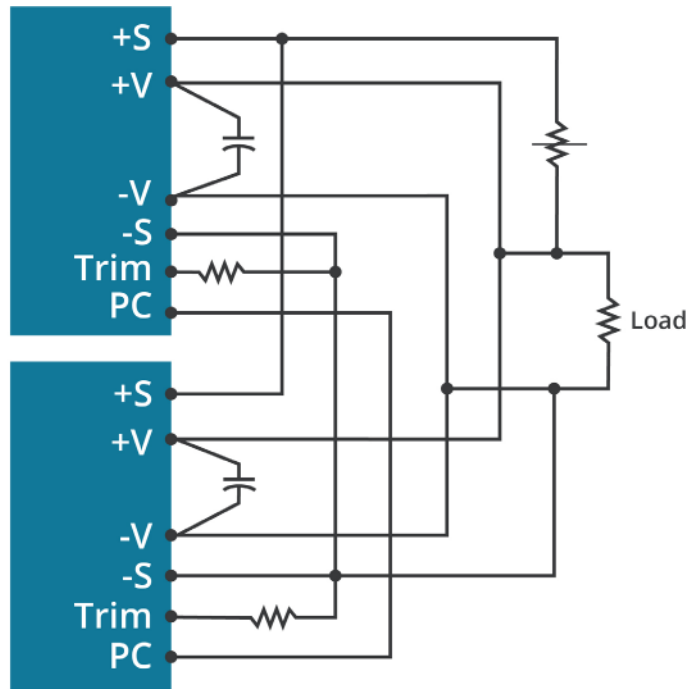

#### N+1 REDUNDANT CONNECTION

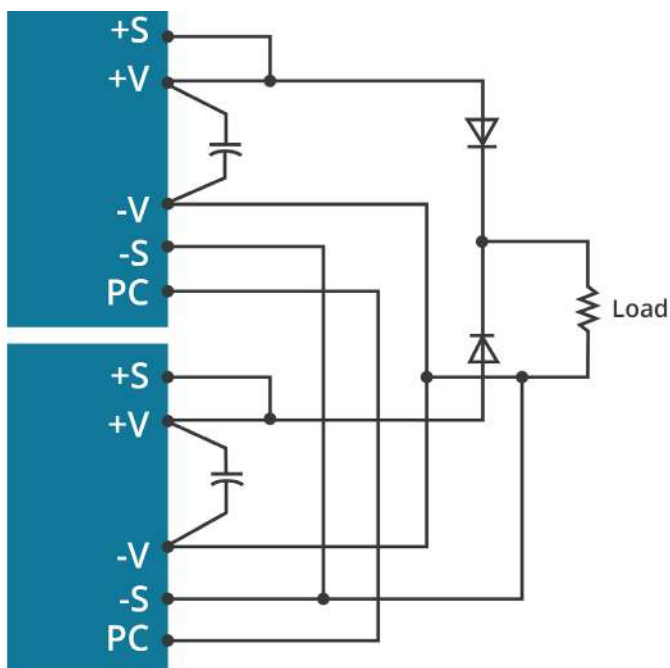

#### N+1 REDUNDANT CONNECTION WITH PROGRAMMED OUTPUT AND ADJUSTABLE OUTPUT VOLTAGE

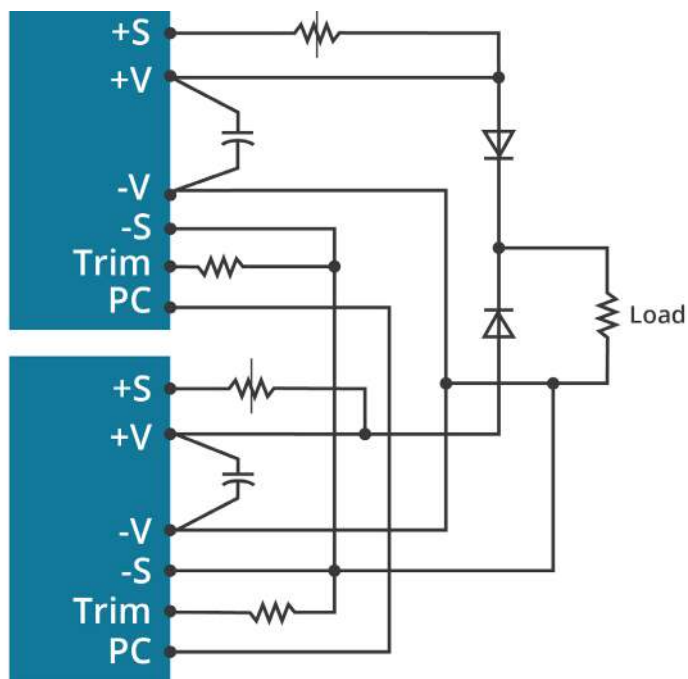

## APPLICATION NOTES (CONTINUED)

### 2. Output Voltage Trimming

Leave open if not used.

**Figure 2**

External Resistors

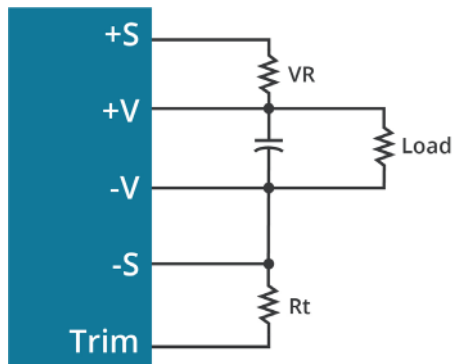

#### Trim-Up/Trim-Down Formulas

$$V_f = \frac{1.24 \times \left( \frac{R_t \times 33}{R_t + 33} \right)}{7.68 + \left( \frac{R_t \times 33}{R_t + 33} \right)}$$

$$V_{out} = (V_o + VR) \times V_f$$

Note:  $R_t = 6.8 \text{ K}\Omega$

$V_o$  is the nominal output voltage

$V_{OUT}$  is the desired output voltage (up or down)

VR is the trim resistor in  $\text{K}\Omega$

**Figure 3**

External DC Voltage

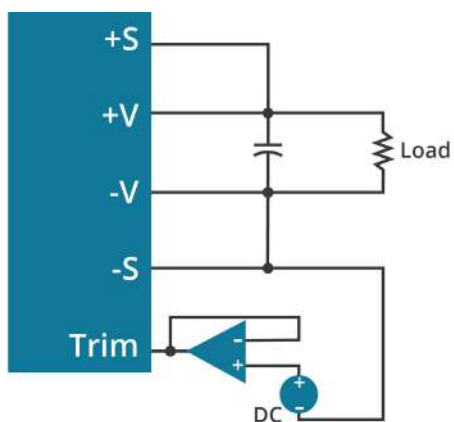

#### Trim-Up/Trim-Down Formulas

$$V_{out} = V_T \times V_o$$

Note:  $V_T$  is the trim terminal voltage

$V_o$  is the nominal output voltage

$V_{OUT}$  is the desired output voltage (up or down)

## REVISION HISTORY

rev.	description	date
1.0	initial release	11/04/2011
1.01	derating curves added	03/12/2012
1.02	V-Infinity branding removed	08/07/2012
1.03	updated spec	03/13/2013
1.04	added parallel operation and trimming information	12/17/2013
1.05	company logo updated	02/15/2021
1.06	derating curve and circuit figures updated	09/13/2021

The revision history provided is for informational purposes only and is believed to be accurate.



**CUI INC**  
a bel group

**Headquarters**  
20050 SW 112th Ave.  
Tualatin, OR 97062  
**800.275.4899**

Fax 503.612.2383  
**cui.com**  
techsupport@cui.com

CUI offers a two (2) year limited warranty. Complete warranty information is listed on our website.

CUI reserves the right to make changes to the product at any time without notice. Information provided by CUI is believed to be accurate and reliable. However, no responsibility is assumed by CUI for its use, nor for any infringements of patents or other rights of third parties which may result from its use.

CUI products are not authorized or warranted for use as critical components in equipment that requires an extremely high level of reliability. A critical component is any component of a life support device or system whose failure to perform can be reasonably expected to cause the failure of the life support device or system, or to affect its safety or effectiveness.