

- NOTES:
- MATERIALS:
HOUSING - LIQUID CRYSTAL POLYMER (LCP),
GLASS-FILLED, UL 94V-0, COLOR: BLACK
SIGNAL PIN - COPPER ALLOY
 - FINISHES:
CONTACT AREA: SELECTIVE GOLD (Au)
PCB TAILS: SELECTIVE MATTE TIN (Sn)
NICKEL (Ni) OVERALL.
 - THIS PART CONFORMS TO MOLEX PRODUCT SPECIFICATION PS-74031-999
 - FOR MIXED CONTACT LENGTHS CONSULT MOLEX FOR AVAILABILITY
 - FOR SPECIFIC MATERIAL NUMBERS & MATING INFORMATION REFER TO SHEET 2
 - PACKAGE PER PK-74061-003
 - MARK PART WITH PART NUMBER & DATE CODE APPROXIMATELY WHERE SHOWN
 - MAPS (MOLEX ADVANCED PLATING SYSTEM)

THE PRIMARY CARTON WITH A LABEL STATING "ELV AND RoHS COMPLAINT" IS LEAD FREE. CARTONS WITHOUT THIS LABEL MAY CONTAIN LEAD.

REV	DESCRIPTION	DATE	APPR	CHKD	DRWNGS	EC NO
G	LEAD FREE CONVERSION	2012/08/24				UCP2013-0687
		2012/11/21				2012/08/24
		2012/12/14				2012/11/21

GENERAL TOLERANCES (UNLESS SPECIFIED)	
mm	INCH
4 PLACES ± .005	± .0004
3 PLACES ± .003	± .0002
2 PLACES ± .002	± .0001
1 PLACE ± .001	± .00005
0 PLACE ±	±

ANGULAR ±1/2°

DRAFT WHERE APPLICABLE MUST REMAIN WITHIN DIMENSIONS

DIMENSION STYLE	
MM ONLY	
DRAWN BY	DATE
JMELTON	2010/05/19
CHECKED BY	DATE
SDANNELLEY	2010/05/19
APPROVED BY	DATE
SMILLER	2010/07/14

SCALE	DESIGN UNITS	THIRD ANGLE PROJECTION
2.5:1	METRIC	
VHDM LITE 8 ROW SIGNAL END BACKPLANE SALES ASSEMBLY		
MATERIAL NO.	DOCUMENT NO.	SHEET NO.
SEE SHEET 2	SD-75198-001	1 OF 2

THIS DRAWING CONTAINS INFORMATION THAT IS PROPRIETARY TO MOLEX INCORPORATED AND SHOULD NOT BE USED WITHOUT WRITTEN PERMISSION

M/N 75198-()	-**0*	-**1*	-**2*	-**3*	-**4*	-**5*	-**6*	-**7*	-**8*
KEYING PIN ORIENTATION	O	A	B	C	D	E	F	G	H

75198 - * * * *

NUMBER OF COLUMNS/PLATING
 10 = 10 COLUMN MATTE TIN (FORMERLY TIN/LEAD)
 25 = 25 COLUMN MATTE TIN (FORMERLY TIN/LEAD)
 60 = 10 COLUMN MATTE TIN (MAPS)
 75 = 25 COLUMN MATTE TIN (MAPS)
 90 = 10 COLUMN MATTE TIN
 85 = 25 COLUMN MATTE TIN

PIN HEIGHT
 1 = 4.75
 2 = 6.25
 3 = 4.25
 4 = 5.15

PART NUMBER	COLUMN	NUMBER OF SIGNAL PIN	NUMBER OF SHIELD	A	B	M	GOLD THICKNESS MICROMETER	TIN THICKNESS MICROMETER
75198-60*1	10	80	0	27.00	18.00	4.75	0.25 MAPS	0.76-1.52
75198-*0*1							0.76	
75198-75*1	25	200	0	57.00	48.00	6.25	0.25 MAPS	
75198-*5*1							0.76	
75198-60*2	10	80	0	27.00	18.00	6.25	0.25 MAPS	
75198-*0*2							0.76	
75198-75*2	25	200	0	57.00	48.00	4.25	0.25 MAPS	
75198-*5*2							0.76	
75198-60*3	10	80	0	27.00	18.00	5.15	0.25 MAPS	
75198-*0*3							0.76	
75198-75*3	25	200	0	57.00	48.00	4.25	0.25 MAPS	
75198-*5*3							0.76	
75198-60*4	10	80	0	27.00	18.00	5.15	0.25 MAPS	
75198-*0*4							0.76	
75198-75*4	25	200	0	57.00	48.00	4.25	0.25 MAPS	
75198-*5*4							0.76	

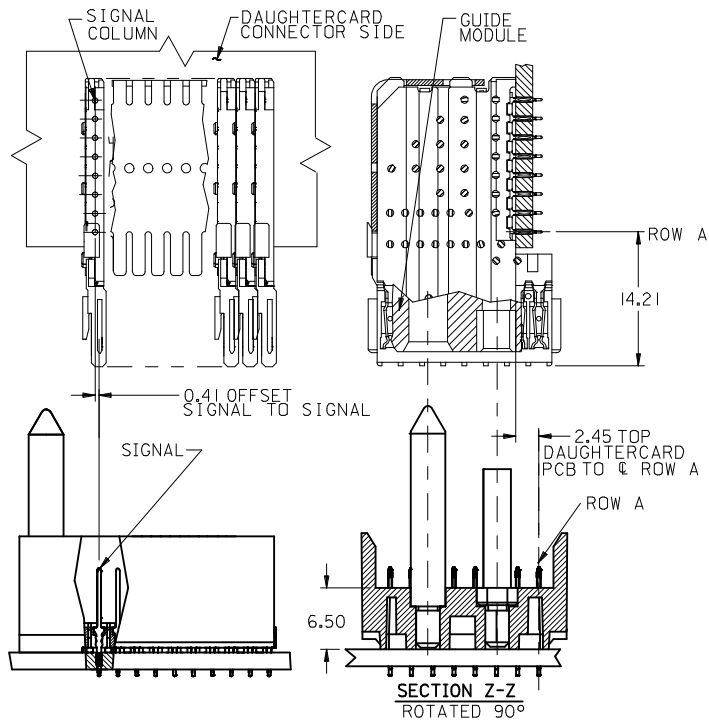

SEE SHEET 1 EC NO: UCP2013-0687 DRWNGES CHKD:MMOLFE APPR:SMILLER 2012/08/24 2012/11/21 2012/12/14	QUALITY SYMBOLS	GENERAL TOLERANCES (UNLESS SPECIFIED)	DIMENSION STYLE MM ONLY	SCALE 2.5:1	DESIGN UNITS METRIC	THIRD ANGLE PROJECTION
	▽=0	mm INCH	DRAWN BY DATE JMELTON 2010/05/19	TITLE	VHDM LITE 8 ROW SIGNAL END BACKPLANE SALES ASSEMBLY molex SD-75198-001 SHEET NO. 2 OF 2	
	▽=0	4 PLACES ± --- ± ---	CHECKED BY DATE SDANNELLEY 2010/05/19			
	▽=0	3 PLACES ± --- ± ---	APPROVED BY DATE SMILLER 2010/07/14			
		2 PLACES ± --- ± ---	MATERIAL NO.	DOCUMENT NO.		
	1 PLACE ± --- ± ---	SEE TABLE	SD-75198-001			
	0 PLACE ± ±	ANGULAR ±1/2°				
		DRAFT WHERE APPLICABLE MUST REMAIN WITHIN DIMENSIONS	SIZE C	THIS DRAWING CONTAINS INFORMATION THAT IS PROPRIETARY TO MOLEX INCORPORATED AND SHOULD NOT BE USED WITHOUT WRITTEN PERMISSION		