

Precision Rotative Transducers, Conductive Plastic, Economic Series (ECO)



The “ECO” models are a comprehensive range of rotational motion transducers for industrial applications.

All mechanical and electrical parameters can be adapted to meet your specifications.

FEATURES

- Size 05 - 09 - 13 are available
- Long life up to 30 million cycles
- Accuracy $\pm 1\%$ down to $\pm 0.25\%$
- Bush or servo mounting types
- Rear mounted terminals
- Following MIL-R-39023 and NFC 93-255 requirements
- Material categorization: for definitions of compliance please see www.vishay.com/doc?99912



RoHS
COMPLIANT

QUICK REFERENCE DATA

Sensor type	ROTATIONAL, conductive plastic
Output type	Output by turrets
Market appliance	Industrial
Dimensions	Various sizes

SIZE	05		09			13		
MODEL	50 ES	50 CB	78 ES	78 CS	78 CB	156 ES	156 CS	156 CB

ELECTRICAL SPECIFICATIONS

Theoretical electrical travel (TET)	Actual electrical angle (AEA) - 2°							
Independent linearity (over TET)	A $\leq \pm 1\%$ (standard)		B $\leq \pm 0.5\%$ (special)			C $\leq \pm 0.25\%$ (special)		
Actual electrical travel (AET)	330° $\pm 5^\circ$		340° $\pm 5^\circ$			350° $\pm 5^\circ$		
Ohmic values (R _T)	1 k Ω - 5 k Ω - 10 k Ω - on request other values							
Ohmic value tolerances at 20 °C	$\pm 10\%$	$\pm 20\%$	$\pm 10\%$	$\pm 20\%$	$\pm 10\%$	$\pm 20\%$	$\pm 10\%$	$\pm 20\%$
Output smoothness	$\leq 0.05\%$							
Maximum power rating at 70 °C	0.2 W		0.3 W			0.5 W		
Wiper current	Recommended: a few μ A - 1 mA max. (continuous)							
Tap (current or voltage)	NA		1 (on request)					
Resistance load on wiper	Minimum 10 ³ x R _T							
End voltage	$\leq 0.2\%$	$\leq 0.5\%$	$\leq 0.2\%$	$\leq 0.5\%$	$\leq 0.2\%$	$\leq 0.5\%$	$\leq 0.2\%$	$\leq 0.5\%$
Insulation resistance	$\geq 1000\text{ M}\Omega$, 500 V _{DC}							
Dielectric strength	$\geq 500\text{ V}_{\text{RMS}}$, 50 Hz							

MECHANICAL SPECIFICATIONS

Mechanical angle (MA)	360° continuous							
On request: stops	NA		340° $\pm 3^\circ$			350° $\pm 3^\circ$		
Mounting type	Servo	Bushing	Servo	Bushing	Servo	Bushing	Servo	Bushing
Shaft guiding	Ball bearings	Sleeve bearings	Ball bearings	Sleeve bearings	Ball bearings	Sleeve bearings	Ball bearings	Sleeve bearings
Shaft	Stainless steel							
Housing	Plastic molding							
Termination	Turrets							
Wiper	Precious metal multi-finger contact							
Starting torque (N.cm) in TET	≤ 0.2	≤ 0.5	≤ 0.2	≤ 0.5	≤ 0.2	≤ 0.5	≤ 0.2	≤ 0.5
Torque on stops (N.cm)	50							
Weight (g)	5 ± 2	8 ± 2	13 ± 2	17 ± 2	29 ± 2	34 ± 2	29 ± 2	34 ± 2
Moment of inertia (g cm ²)	≤ 0.5		≤ 1			≤ 2		

PERFORMANCE		
MODELS	ES	CS and CB
Life (10 ⁶ cycles)	30	20
Temperature range	-55 °C to +125 °C	
Climatic category	55/125/04	
Speed rotation (RPM)	600	150
Sine vibration on 3 axes	1.5 mm or 20 g from 10 Hz to 2000 Hz	
Mechanical shocks on 3 axes	50 g - 11 ms - half sine	

Note

- Nothing stated herein shall be construed as a guarantee of quality or durability
- Life under Vishay laboratory conditions

DIMENSIONS in millimeters, general tolerance ± 0.5 mm

SIZE 05/09/13

SERVO MOUNT TYPE

- 50 ES
- 78 ES
- 78 CS
- 156 ES
- 156 CS

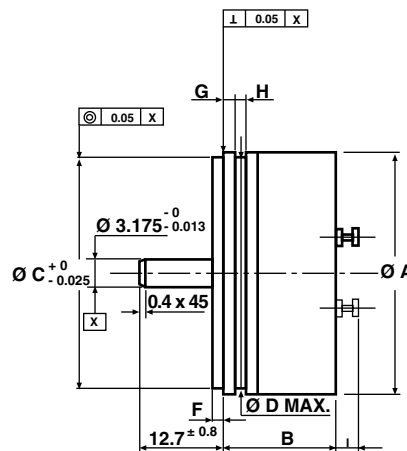

DIMENSIONS	DESIGNATION	SIZE 05	SIZE 09		SIZE 13	
		50 ES	78 ES	78 CS	156 ES	156 CS
Ø A	Ø housing	12.7	22.2		33.3	
B	Length	13.0	13.5		18.0	
Ø C	Ø pilot	9.525	19.05		30.16	
Ø D max.	Ø groove	11.45	19.64		30.9	
F	Flange thickness	1 ± 0.1			1.6 ± 0.1	
G	Shoulder	1.2 ± 0.1			1.6 ± 0.1	
H	Dia. of groove	1.2 ± 0.2			1.5 min.	
I max.	Height of the turret	2.5	2.5		3.6	

SIZE 05/09/13

BUSHING MOUNT TYPE

- 50 CB
- 78 CB
- 156 CB

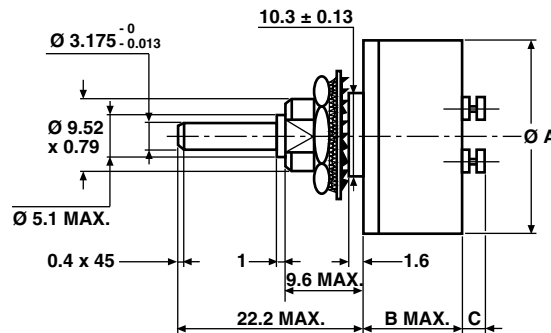

DIMENSIONS	DESIGNATION	SIZE 05	SIZE 09	SIZE 13
		50 CB	78 CB	156 CB
Ø A	Ø housing	12.7	22.2	33.3
B max.	Length	11	11.5	16
C max.	Height of the turret	2.5	2.5	3.6

DIMENSIONS in millimeters, general tolerance ± 0.5 mm

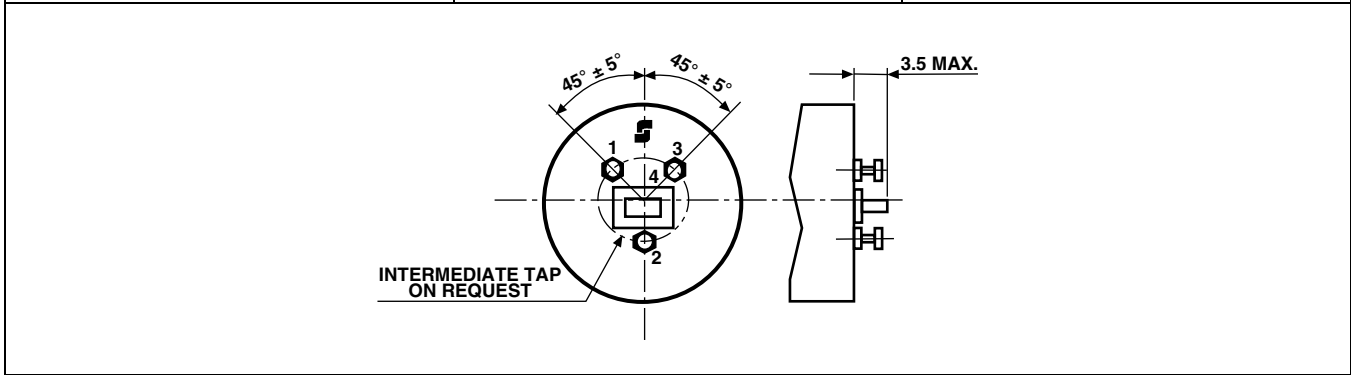
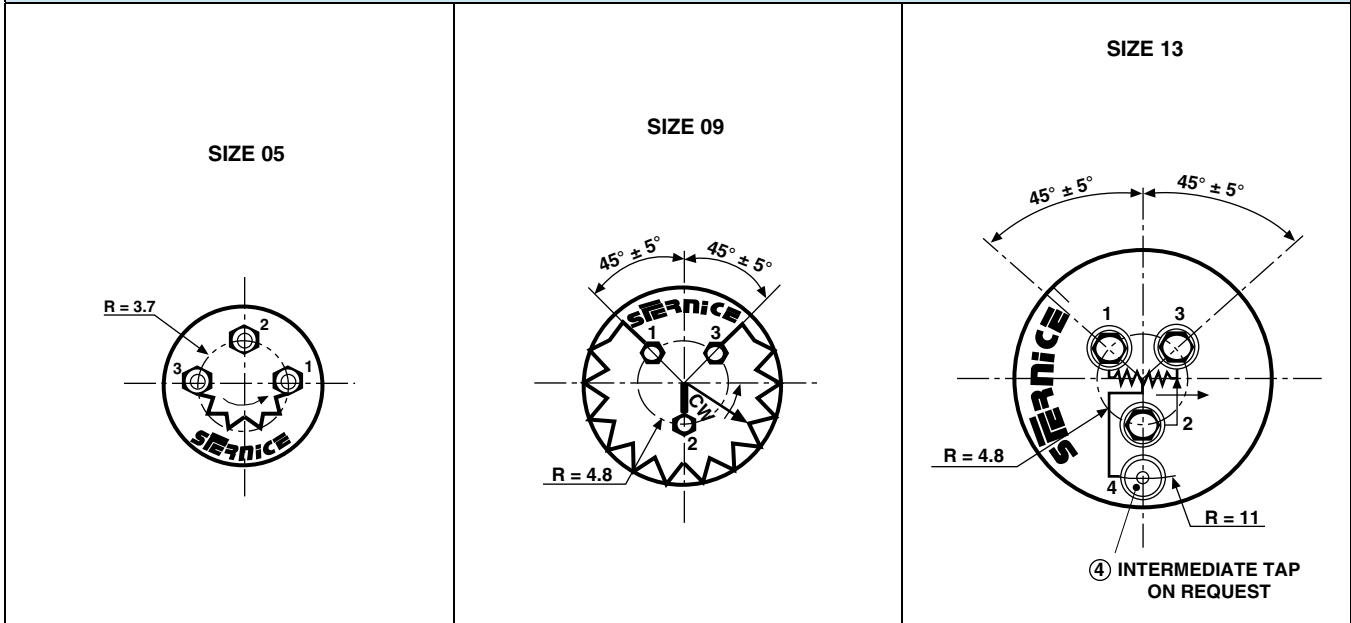

ORDERING INFORMATION/DESCRIPTION

ECO	78	E	S	A	T	103	e4
SERIES	MODEL	TYPE	FIXATION	LINEARITY CODE	TAP	OHMIC VALUE	LEAD FINISH
		E = Ball bearings C = Sleeve bearings	S: Servo B: Bushing	A: $\pm 1\%$ B: $\pm 0.5\%$ C: $\pm 0.25\%$	On request T: Voltage U: Current position to be specified	First 2 digits are significant numbers 3 rd digit indicates number of zeros	

Special characteristics and designs on request

SAP PART NUMBERING GUIDELINES

ECO	78CB	C	502
SERIES	MODEL	LINEARITY	OHMIC VALUE



Disclaimer

ALL PRODUCT, PRODUCT SPECIFICATIONS AND DATA ARE SUBJECT TO CHANGE WITHOUT NOTICE TO IMPROVE RELIABILITY, FUNCTION OR DESIGN OR OTHERWISE.

Vishay Intertechnology, Inc., its affiliates, agents, and employees, and all persons acting on its or their behalf (collectively, "Vishay"), disclaim any and all liability for any errors, inaccuracies or incompleteness contained in any datasheet or in any other disclosure relating to any product.

Vishay makes no warranty, representation or guarantee regarding the suitability of the products for any particular purpose or the continuing production of any product. To the maximum extent permitted by applicable law, Vishay disclaims (i) any and all liability arising out of the application or use of any product, (ii) any and all liability, including without limitation special, consequential or incidental damages, and (iii) any and all implied warranties, including warranties of fitness for particular purpose, non-infringement and merchantability.

Statements regarding the suitability of products for certain types of applications are based on Vishay's knowledge of typical requirements that are often placed on Vishay products in generic applications. Such statements are not binding statements about the suitability of products for a particular application. It is the customer's responsibility to validate that a particular product with the properties described in the product specification is suitable for use in a particular application. Parameters provided in datasheets and / or specifications may vary in different applications and performance may vary over time. All operating parameters, including typical parameters, must be validated for each customer application by the customer's technical experts. Product specifications do not expand or otherwise modify Vishay's terms and conditions of purchase, including but not limited to the warranty expressed therein.

Hyperlinks included in this datasheet may direct users to third-party websites. These links are provided as a convenience and for informational purposes only. Inclusion of these hyperlinks does not constitute an endorsement or an approval by Vishay of any of the products, services or opinions of the corporation, organization or individual associated with the third-party website. Vishay disclaims any and all liability and bears no responsibility for the accuracy, legality or content of the third-party website or for that of subsequent links.

Except as expressly indicated in writing, Vishay products are not designed for use in medical, life-saving, or life-sustaining applications or for any other application in which the failure of the Vishay product could result in personal injury or death. Customers using or selling Vishay products not expressly indicated for use in such applications do so at their own risk. Please contact authorized Vishay personnel to obtain written terms and conditions regarding products designed for such applications.

No license, express or implied, by estoppel or otherwise, to any intellectual property rights is granted by this document or by any conduct of Vishay. Product names and markings noted herein may be trademarks of their respective owners.