

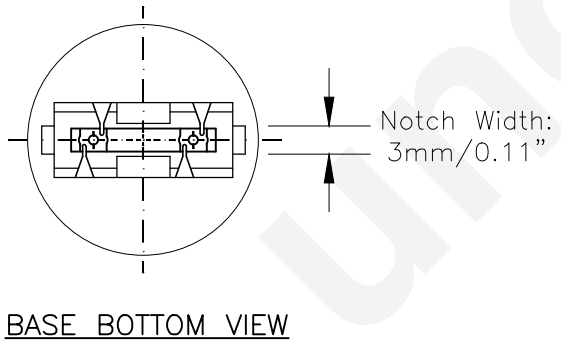

Since 1959

PART NO.	BASE TYPE	DESIGN VOLTS	DESIGN AMPS	MSCD	FILAMENT TYPE	AVERAGE LIFE HOURS	REVISIONS			
							REV #	DESCRIPTION	DATE	APPROVED
5702NAK	D.F. Plastic Wedge W2.5X16q	12.8V 14.0V	2.23±5% 0.59±8%	24±30% 2.2±30%	C-6 C-6	4000 10000	1	ISSUED	10/21/2014	R.M.
							2	ADDED FILAMENT DISTANCE DIMENSIONS	10/04/2018	R.M.

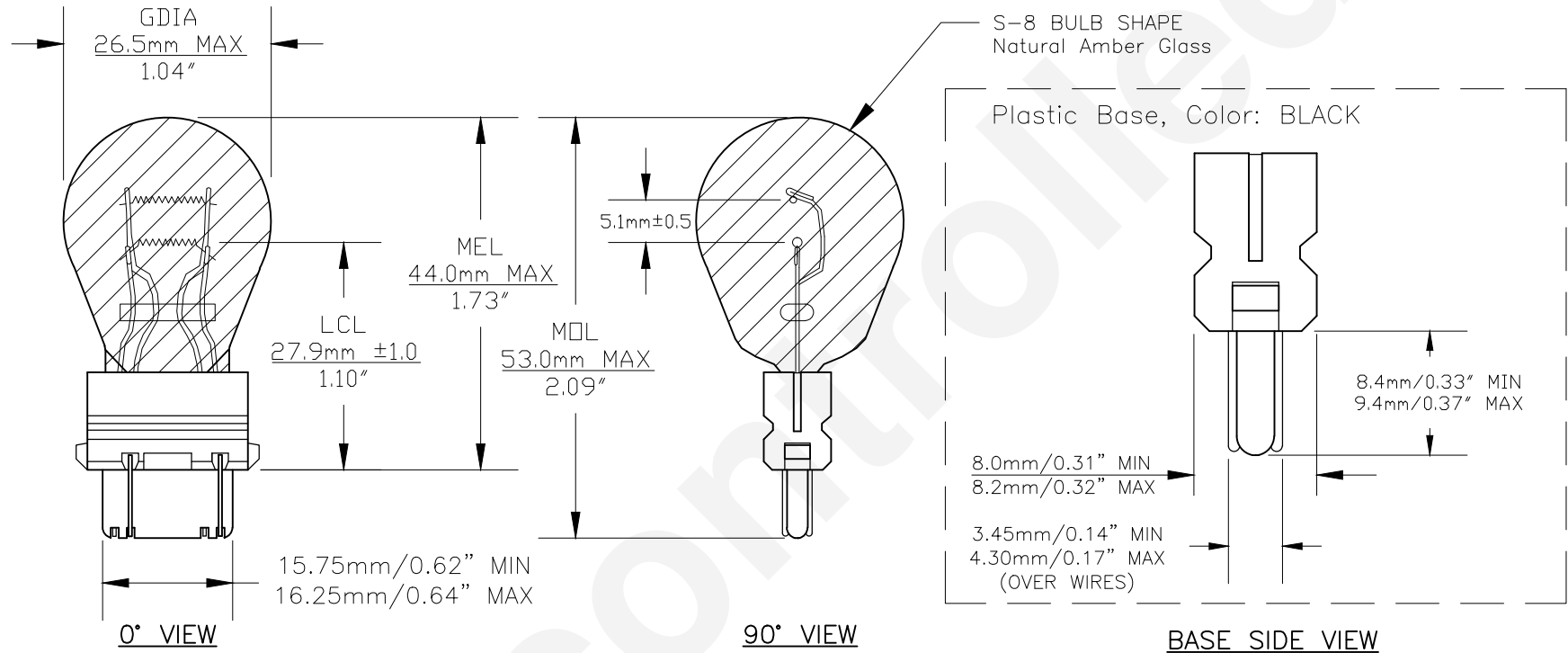

Note: Made according to SAE specifications



UNLESS OTHERWISE SPECIFIED: DIMENSIONS ARE IN INCHES TOLERANCES		CEC INDUSTRIES LTD			
DECIMALS .XX ± .05		599 BOND STREET		LINCOLNSHIRE, IL 60069	
ANGULAR .XXX ± .010		TITLE LIGHT BULB NO. 5702NAK			
FRACTIONAL ±1/64		SIZE A	FSCM NO.	DWG NO. 5702NAK	REV 2
DRAWN ROSE MEDINA	DATE 10/21/2014	SCALE		PLOT SCALE	SHEET 1 OF 1
CHECKED		FILE 5702NAK.pdf		DRAWING NOT TO SCALE	