

THIS DRAWING IS UNPUBLISHED. RELEASED FOR PUBLICATION 20  
 © COPYRIGHT 20 BY - ALL RIGHTS RESERVED.

REVISIONS					
P	LTR	DESCRIPTION	DATE	DWN	APVD
A		REVISED PER ECR-11-015546	29OCT2011	HVG	DD

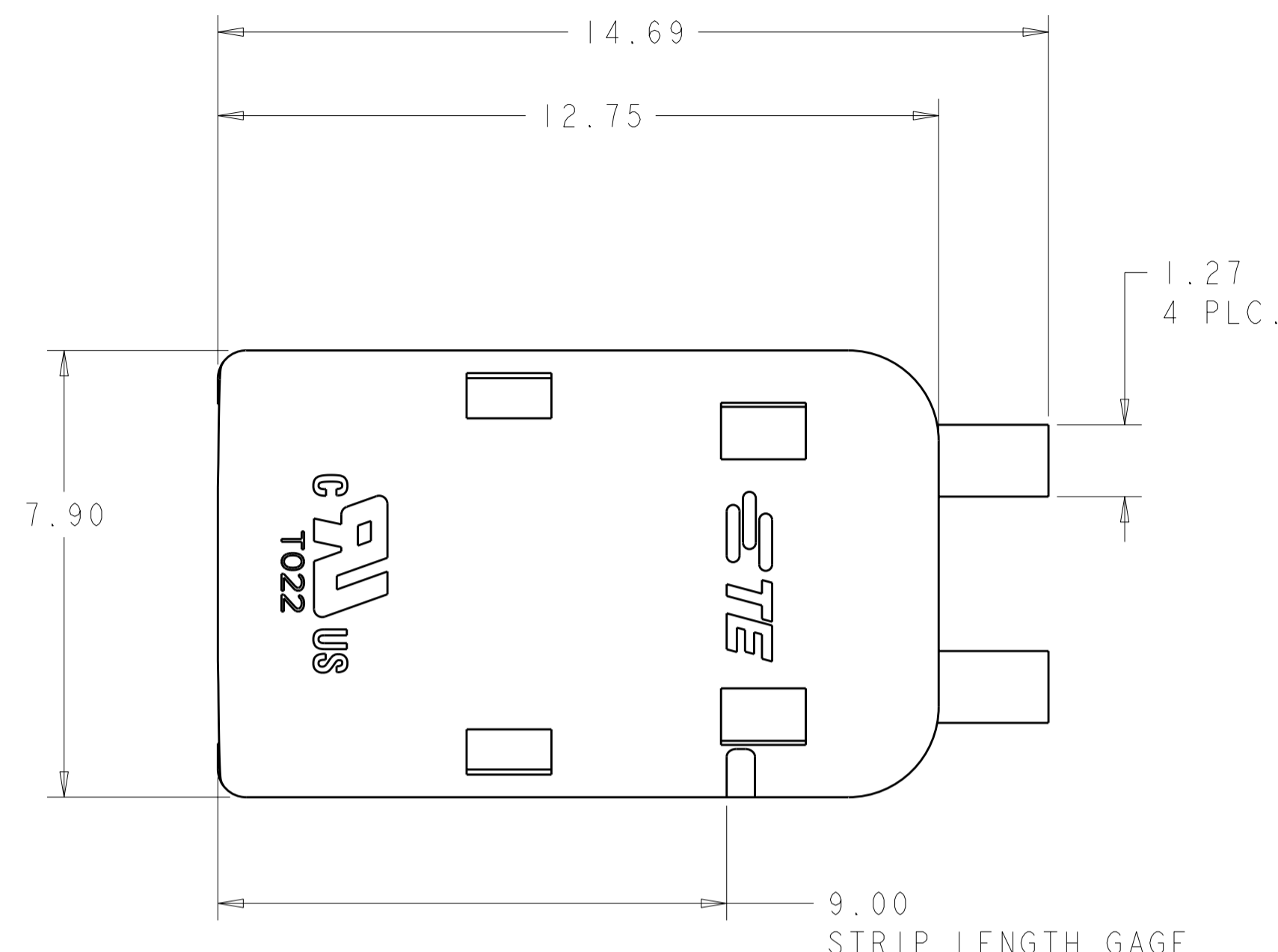

- NOTES :
- 1. MATERIALS AND FINISH:
    - HOUSING: LCP, COLOR: WHITE
    - CONTACTS: COPPER ALLOY, FINISH: TIN
  - 2. MUST COMPLY WITH DIRECTIVE 2002/95/EC (ROHS)
  - 3. THIS PRODUCT HAS NOT COMPLETED VALIDATION TESTING
  - 4. WIRE TYPES AND SIZES ACCEPTED
    - 18, 20 AND 22 AWG SOLID WIRE
    - 18 AND 20 AWG PREBOND STRANDED WIRE
    - 18 AWG STRANDED WIRE (16 STRAND COUNT)
    - MAX INSULATION OD: 2.10 MM (.083")
    - STRIP LENGTH: 9.0±1.0 (.354")
  - 5. PACKAGED IN TAPE AND REEL

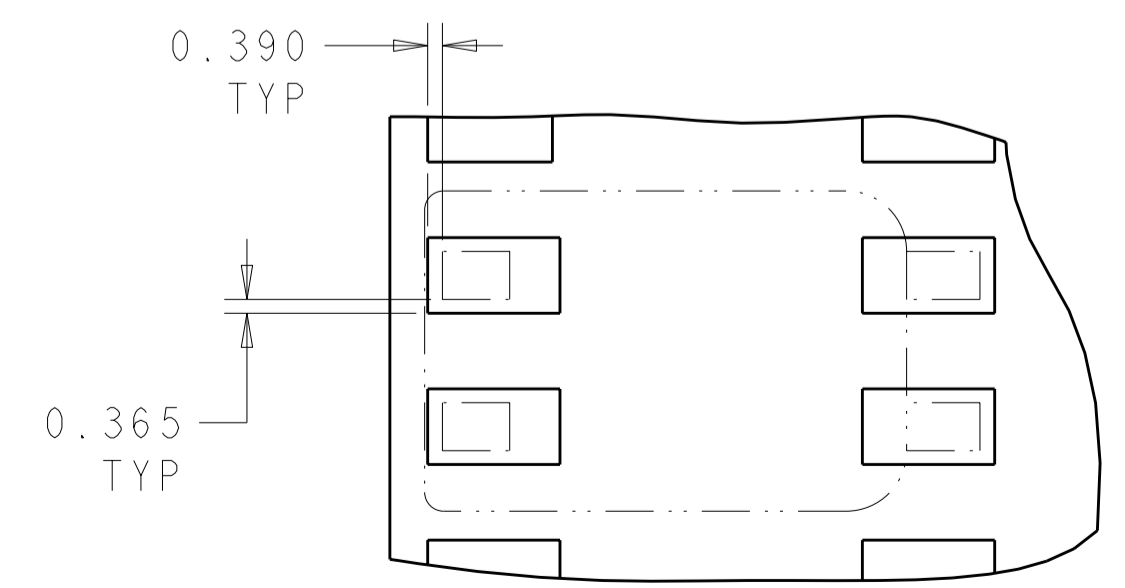
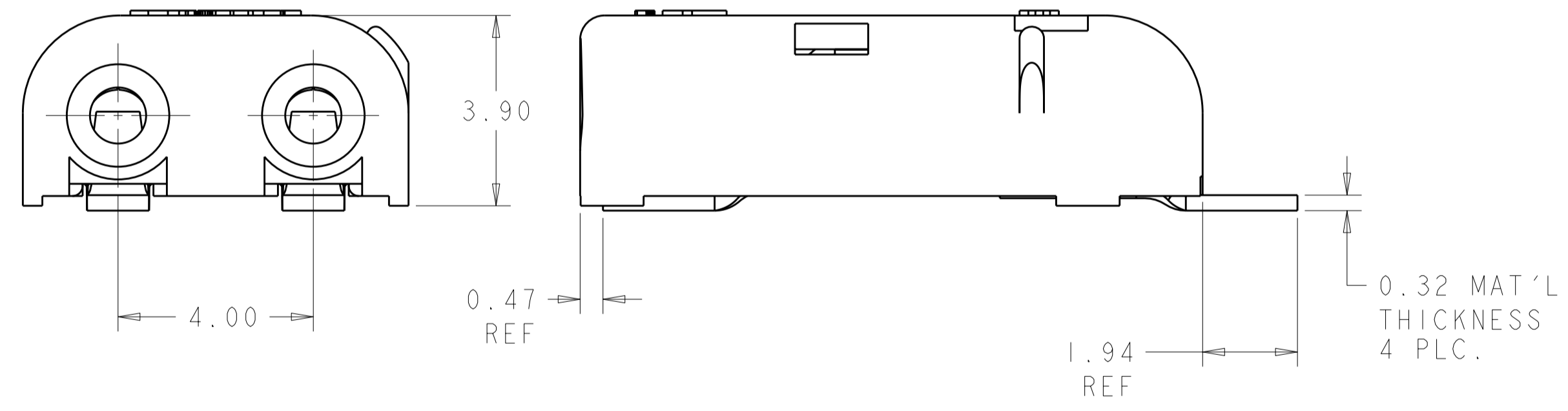
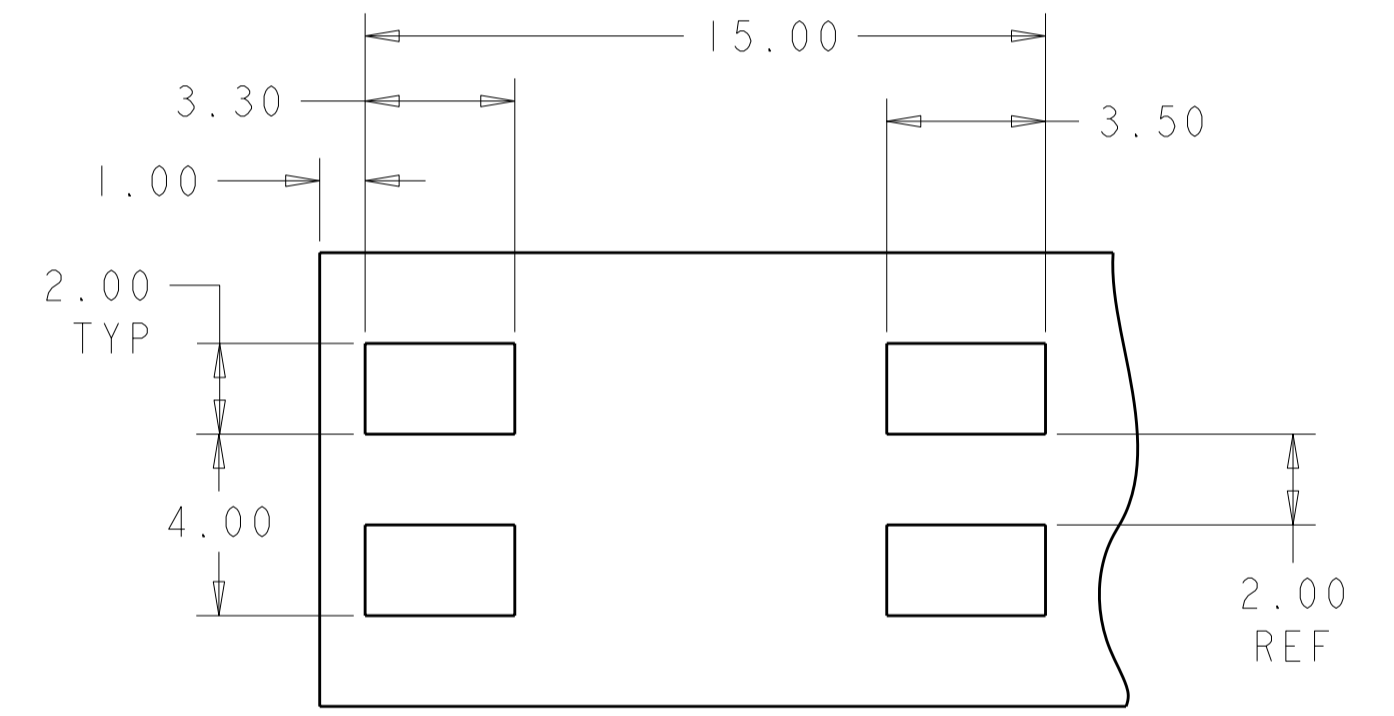

RECOMMENDED CONNECTOR PLACEMENT  
SCALE 5:1

5	1	WHITE	2154662-1
PACKAGING	MATERIAL	COLOR	PART NO.

THIS DRAWING IS A CONTROLLED DOCUMENT.		DWN C. DAILY 12MAY2011	TE Connectivity	
		CHK D. DECKER 12MAY2011	POKE-IN LED CONNECTOR ASSEMBLY, 2 POSITION SMT - EXTENDED	
DIMENSIONS: mm		APVD -	NAME	
TOLERANCES UNLESS OTHERWISE SPECIFIED:		PRODUCT SPEC 108-2284	SIZE	
0 PLC ±		APPLICATION SPEC	CAGE CODE	
1 PLC ±0.5		WEIGHT	DRAWING NO	
2 PLC ±0.10		RESTRICTED TO	A200779C-2154662	
3 PLC ±			SCALE 3:1	
4 PLC ±			SHEET 1 OF 2	
ANGLES ±3°			REV A	
FINISH				
SEE TABLE	SEE TABLE	CUSTOMER DRAWING		

THIS DRAWING IS UNPUBLISHED. RELEASED FOR PUBLICATION 20  
 © COPYRIGHT 20 BY - ALL RIGHTS RESERVED.

LOC	DIST	REVISIONS				
P	LTR	DESCRIPTION	DATE	DWN	APVD	
AF	50	-	SEE SHEET 1	-	-	

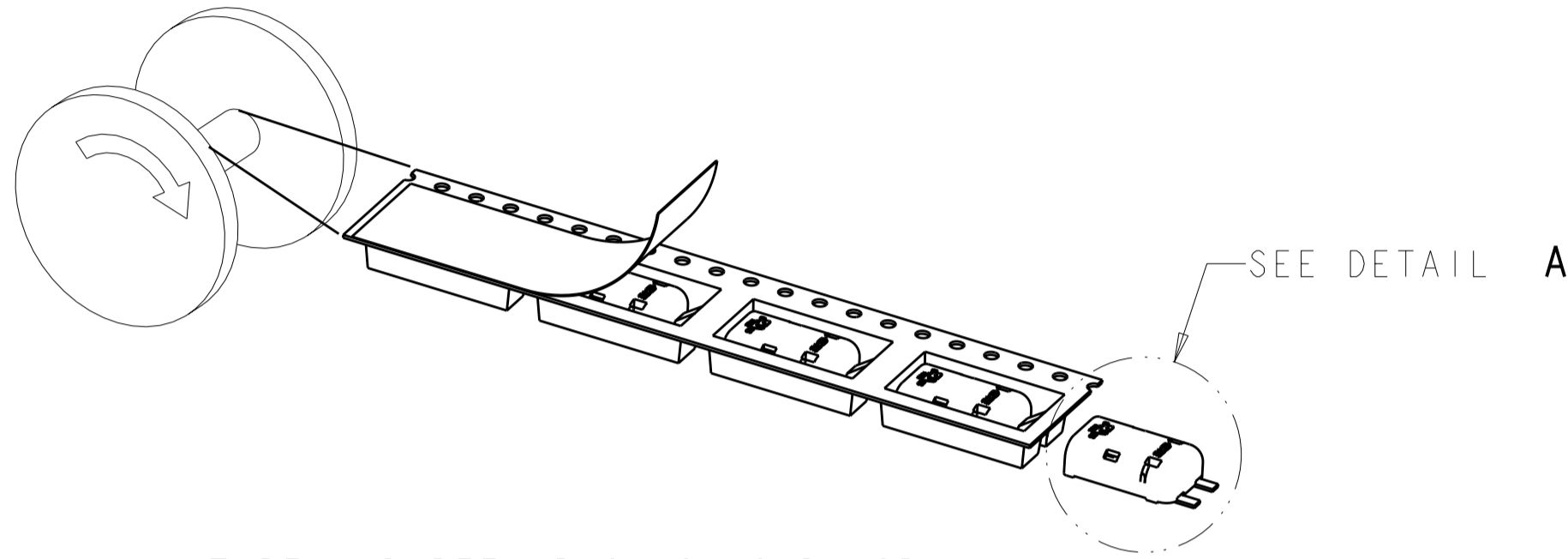

TAPE AND REEL PACKAGING DIAGRAM

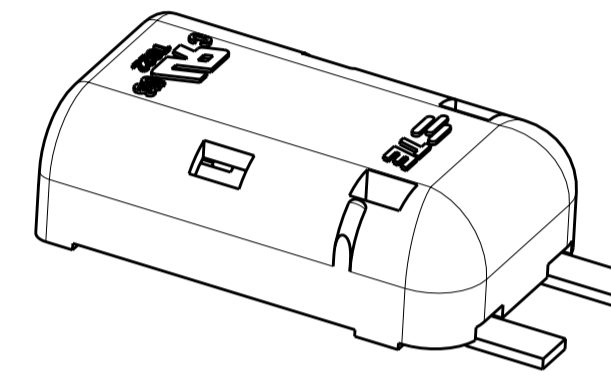

DETAIL A  
SCALE 5:1

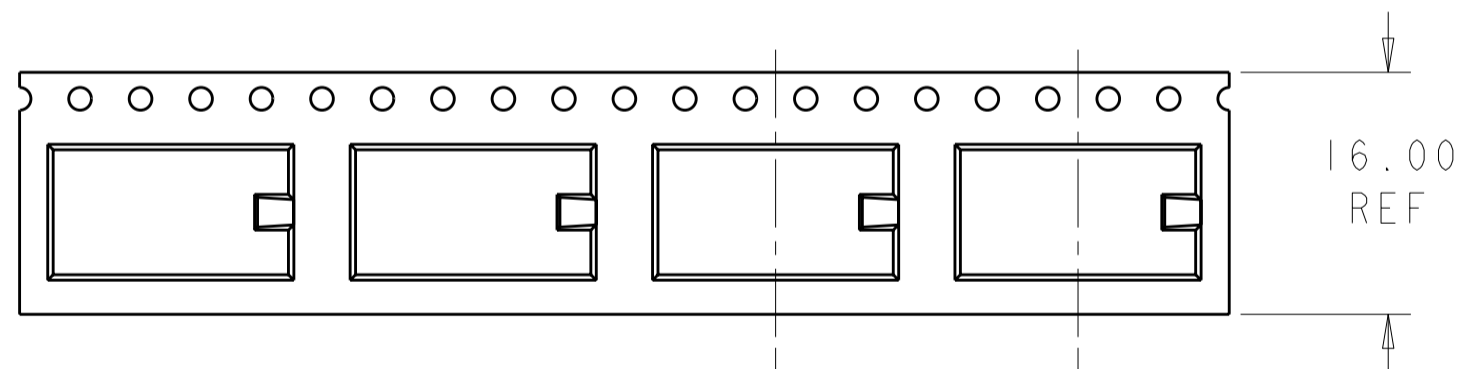

20.00 REF  
TYP

16.00  
REF

SCALE 2:1

THIS DRAWING IS A CONTROLLED DOCUMENT.		DWN C. DAILY 12MAY2011	TE Connectivity	
		CHK D. DECKER 12MAY2011		
DIMENSIONS: mm		APVD -	NAME POKE-IN LED CONNECTOR ASSEMBLY, 2 POSITION SMT - EXTENDED	
TOLERANCES UNLESS OTHERWISE SPECIFIED:		PRODUCT SPEC 108-2284	SIZE A200779	
0 PLC ± 1 PLC ±0.5 2 PLC ±0.10 3 PLC ± 4 PLC ±		APPLICATION SPEC -	DRAWING NO C-2154662	
MATERIAL SEE TABLE		FINISH SEE TABLE	RESTRICTED TO -	
		WEIGHT -	SCALE 3:1 SHEET 2 OF 2 REV A	
		CUSTOMER DRAWING		