

THIS DRAWING IS UNPUBLISHED. RELEASED FOR PUBLICATION
 © COPYRIGHT - By - ALL RIGHTS RESERVED.

LOC	DIST	REVISIONS			
P	LTR	DESCRIPTION	DATE	DWN	APVD
CM	53	L1	REV PER ECR 12-013810	24SEPT12	JR TM

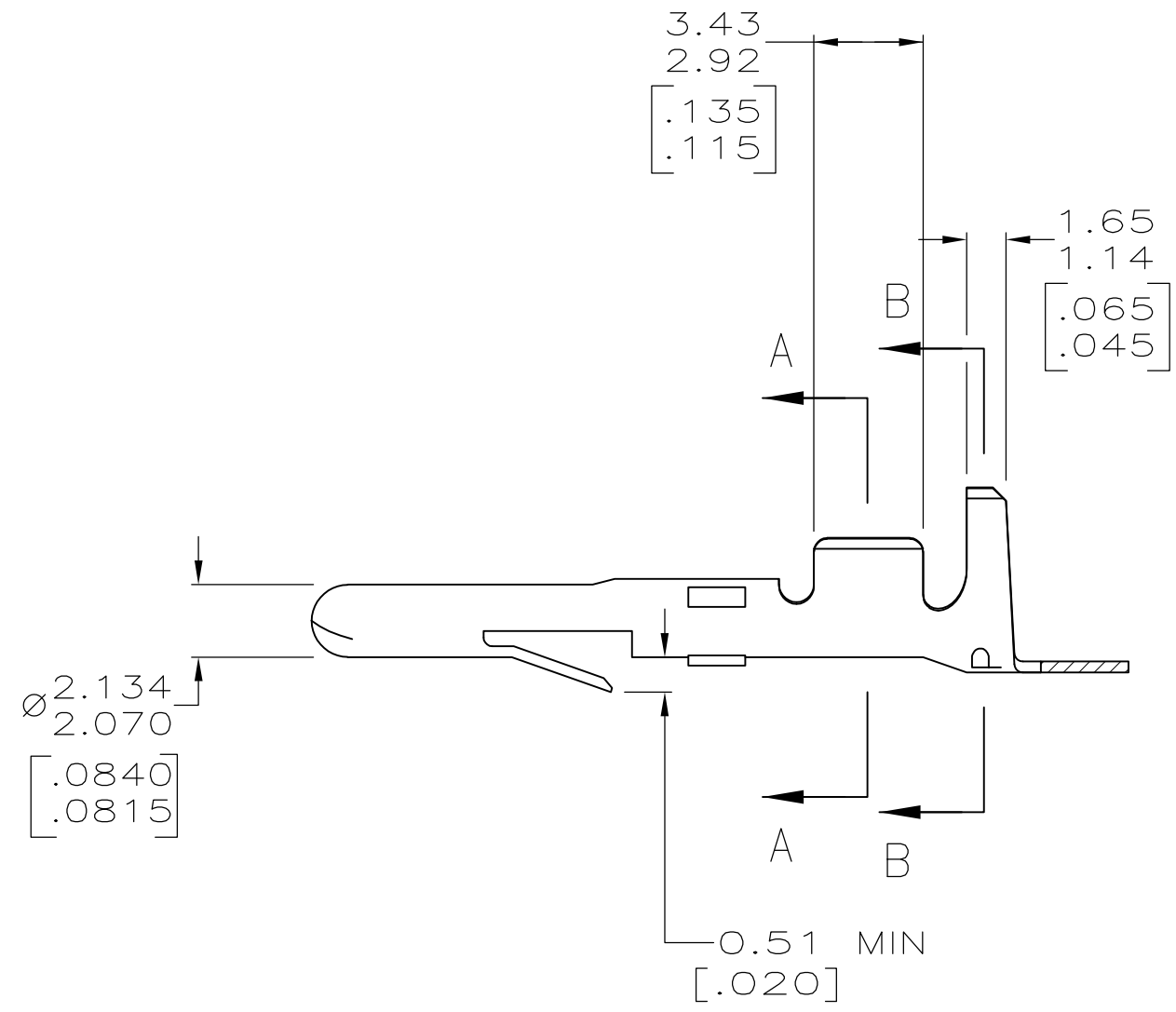

1. WIRE RANGE: 2 WIRES OF 0.8 – 0.9 mm² [18 AWG] OR 1 WIRE OF 0.8 – 0.9 mm² [18 AWG] AND 1 WIRE OF 1.25 – 1.4 mm² [16 AWG].
2. INSULATION RANGE: 2 WIRES OF 2.92 [.115] MAX DIA EACH, STACKED.
3. DIMENSIONS IN BRACKETS ARE IN INCHES.

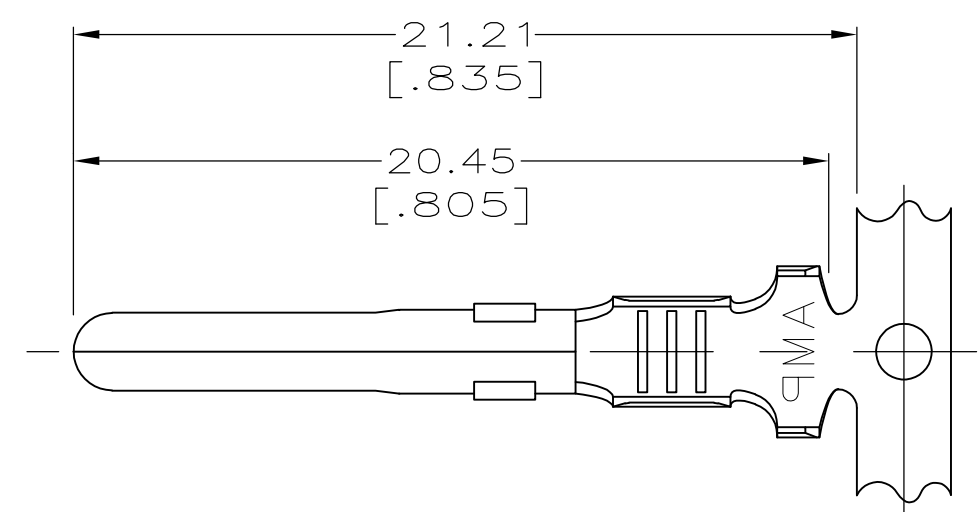
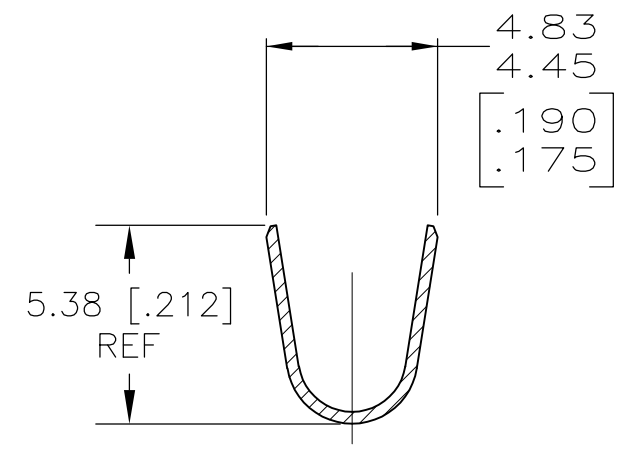
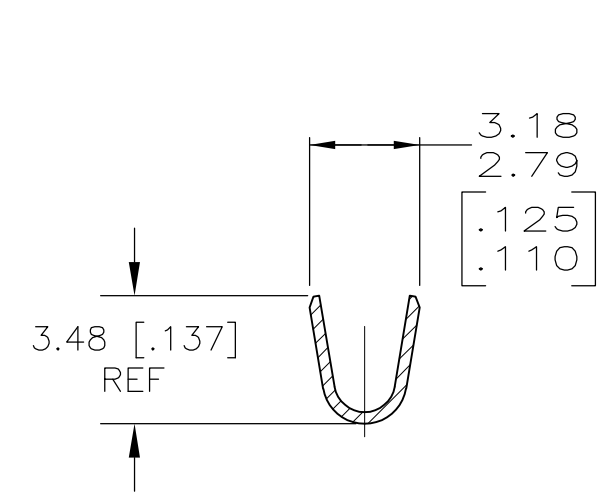

SECTION A-A

SECTION B-B

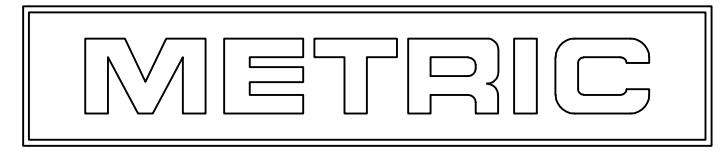

PRE-TIN	0.30 [.012] PH BRZ	350558-4
PRE-TIN	0.30 [.012] BRASS	350558-1
FINISH	MATERIAL	PART NO.

THIS DRAWING IS A CONTROLLED DOCUMENT.		DWN T. BECK 1-20-93	TE Connectivity NAME PIN, MATE-N-LOK			
DIMENSIONS: MM [INCHES]		CHK R. SWING 1-20-93				
TOLERANCES UNLESS OTHERWISE SPECIFIED:		APVD C. MARTIN 1-25-93				
0 PLC ± - 1 PLC ± - 2 PLC ± 0.25 [.010] 3 PLC ± - 4 PLC ± - ANGLES ± -		PRODUCT SPEC				
MATERIAL SEE TABLE	FINISH SEE TABLE	APPLICATION SPEC	SIZE A2	CAGE CODE 00779	DRAWING NO 350558	RESTRICTED TO
CUSTOMER DRAWING			SCALE 5:1	SHEET 1 of 1	REV L1	