

ENG. NO.	ORDER NO.	PIN STYLE	HSG. MATERIAL	PIN PLATING
A-5219-09B	15-31-1096	SOLID	94V-2 NYLON	TIN
A-5219-09C	15-31-2096	SOLID	94V-2 NYLON	TIN
A-5219-09D	15-31-3096	HOLLOW	94V-2 NYLON	TIN
A-5219-09B-201	PRELIMINARY	SOLID	94V-0 NYLON	TIN
A-5219-09BG	PRELIMINARY	SOLID	94V-2 NYLON	GOLD
A-5219-09BG-201	PRELIMINARY	SOLID	94V-0 NYLON	GOLD

HOUSING MATERIAL:
 1 - NYLON TYPE 66, 94V-2, NATURAL
 2 - NYLON TYPE 66, 94V-0, NATURAL

PIN MATERIAL: BRASS

PIN PLATING:
 1 - POST PLATE .000120/(0.00305) MIN. TIN OVER .000040/(0.0010) MIN. NICKEL
 2 - POST PLATE .000014/(0.00035) MIN. GOLD OVER .000080/(0.00200) MIN. NICKEL

NOTES:
 1. THESE HEADERS ARE FOR USE ON .062/(1.57) THICK P.C. BOARDS AND MATE WITH 3191-9 SERIES RECEPTACLES.
 2. CIRCUIT I.D. RIBS NOT PRESENT ON PARTS FROM TOOLS BUILT PRIOR TO 6/96.
 3. SEE PK-5219-002 FOR PACKAGING INFORMATION.

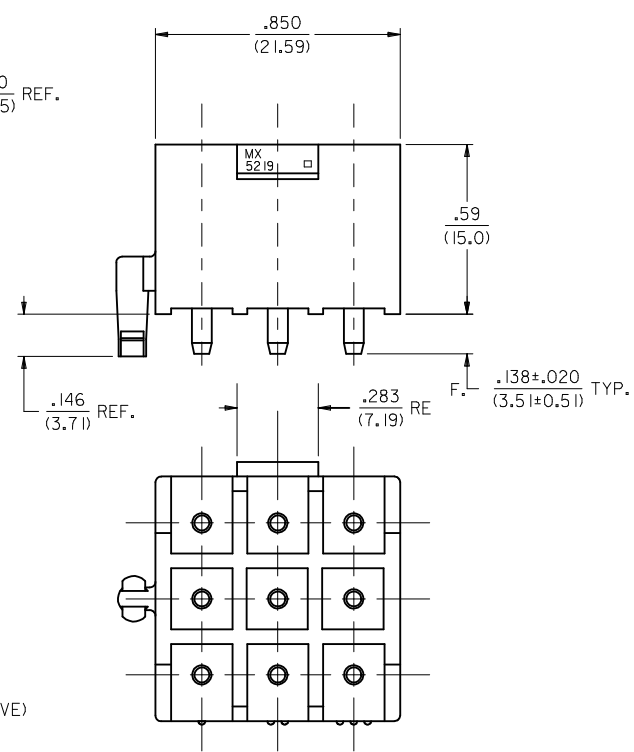
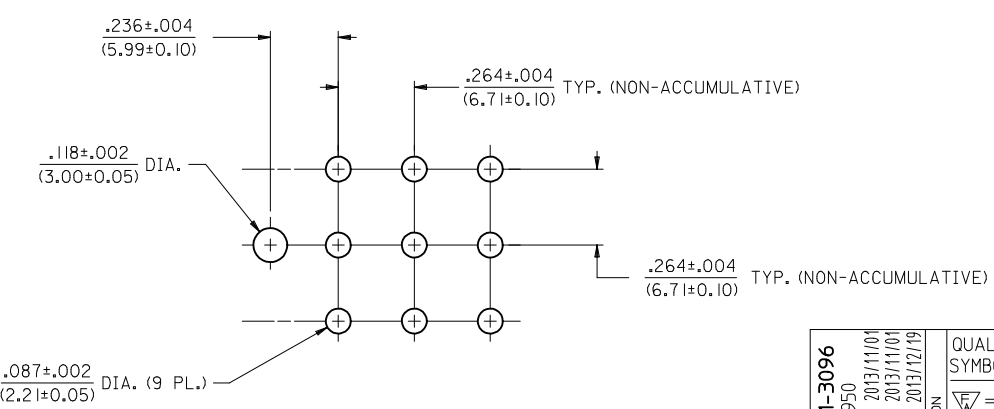
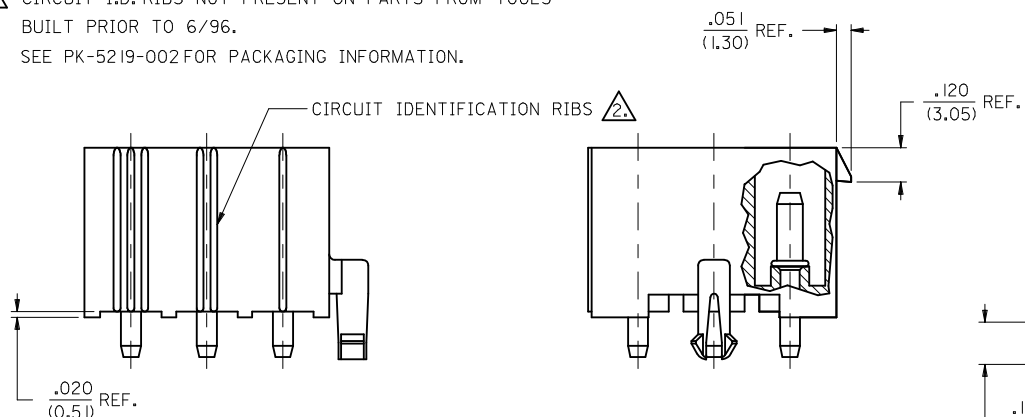
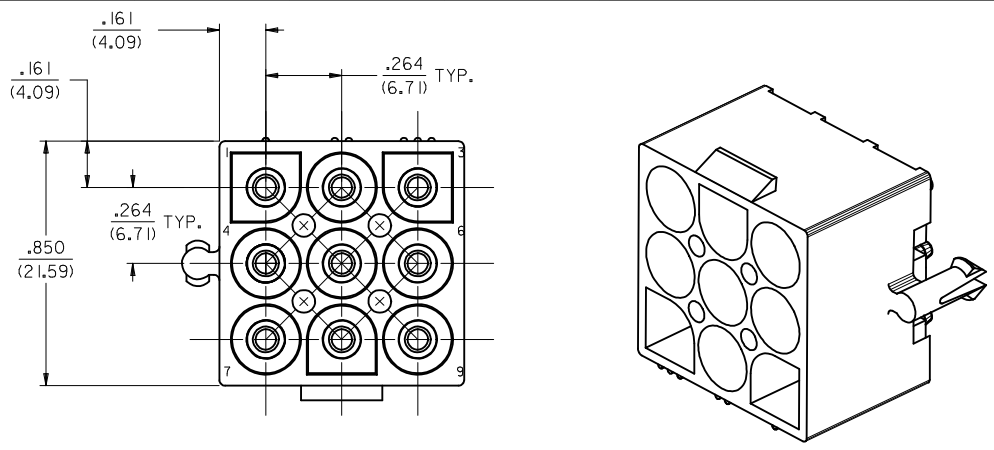

RECOMMENDED P.C. BOARD LAYOUT

ADD P/N 15-31-3096 EC NO: UCP2014-1950 DRW:NAELHAG 2013/11/01 CHKD:JBELL 2013/11/01 APPR:FSMITH 2013/12/19 REV: C5	QUALITY SYMBOLS ▽=0 ▽=0 ▽=0	GENERAL TOLERANCES (UNLESS SPECIFIED)		DIMENSION STYLE IN/MM	SCALE 3:1	DESIGN UNITS INCH	THIRD ANGLE PROJECTION
		4 PLACES ± --- ± --- 3 PLACES ± --- ± .010 2 PLACES ± 0.25 ± .014 1 PLACE ± 0.35 ± ---	mm INCH DRAWN BY DATE CM 1996/05/23 CHECKED BY DATE RW 1996/05/23 APPROVED BY DATE	TITLE .093/(2.36) SERIES 9 CIRCUIT HEADER ASSEMBLY			
DRAFT WHERE APPLICABLE MUST REMAIN WITHIN DIMENSIONS		MATERIAL NO. SEE CHART		MOLEX INCORPORATED		SHEET NO. 1 OF 1	
THIS DRAWING CONTAINS INFORMATION THAT IS PROPRIETARY TO MOLEX INCORPORATED AND SHOULD NOT BE USED WITHOUT WRITTEN PERMISSION							