

used for: D-SUB

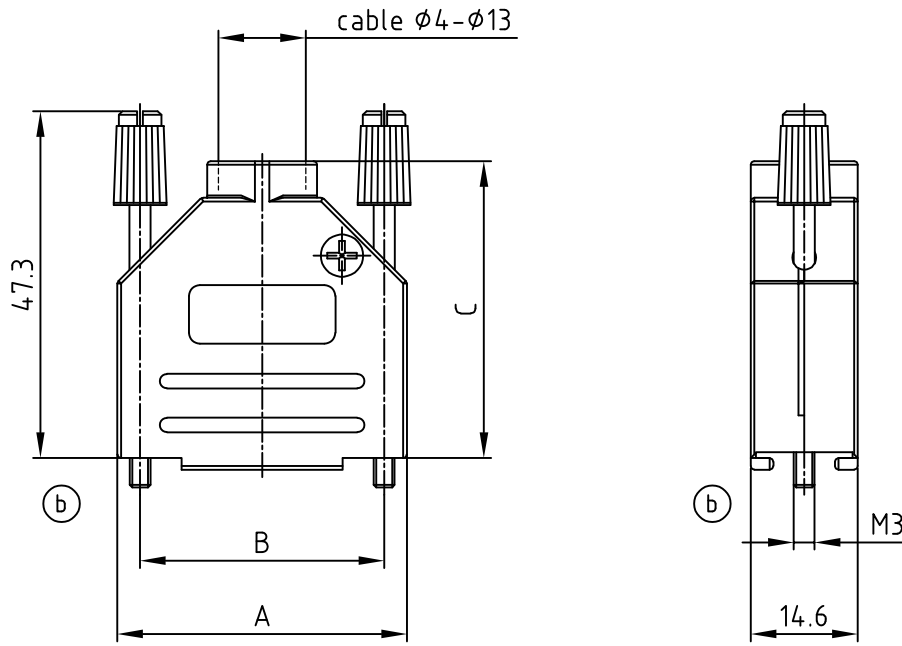

No. of pos.	A	B	C	Part NO. Bulk package	Part NO. Single package
9	31.2	25.0	38.3	165X02649X	165X02649XE
15	39.3	33.3	40.5	165X02659X	165X02659XE
25	53.4	47.0	47.8	165X02669X	165X02669XE
37	69.9	63.5	52.2	165X02679X	165X02679XE

(b) TECHNICAL DATA:

1. BACKSHELL HALVES: ZINC DIE-CAST; NICKEL PLATED
2. ASSEMBLY SCREWS: STEEL; TIN PLATED
3. JACK SCREWS: STEEL; TIN PLATED + PA6
4. CABLE STRAIN RELIEF: PC
5. TEMPERATURE RANGE: -40°C to +120°C
6. ATTENUATION FACTOR: >40dB BETWEEN 30 MHz AND 1 GHz
7. ASSEMBLY INSTRUCTION SEE SHEET 2

RoHS compliant

THIS DRAWING MAY NOT BE COPIED OR REPRODUCED IN ANY WAY, AND MAY NOT BE PASSED ON TO A THIRD PARTY WITHOUT WRITTEN PERMISSION.
 OWNERSHIP AND COPYRIGHT OF CONEC GmbH
 DO NOT ALTER CAD DRAWING BY HAND

tolerance		dim. in mm	
2006	date	name	
drawn	23.03.	Lehmenkühler	
appd.	24.03.	Mickenbecker	
norm			
d-old			
4 x b	Ä 4169	30.11.2011	Lehmen.
a	Original		
rev.	description	date	name



scale:	1:1
material:	SEE NOTES
title:	METAL HOOD 9-37pos. EMI/RFI SHIELDING with straight cable exit and jack screws
dwg no:	16K1A1784
part no:	SEE TABLE
	DIN-A 4 sh:1/2

4

3

2

1

used for:

D-SUB

ASSEMBLY INSTRUCTION:

Use two halves of strain relief
different sizes can be mixed

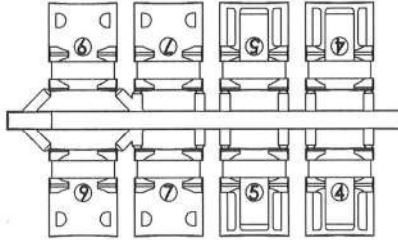

Strip cable 18mm and
shape cable to two pigtails

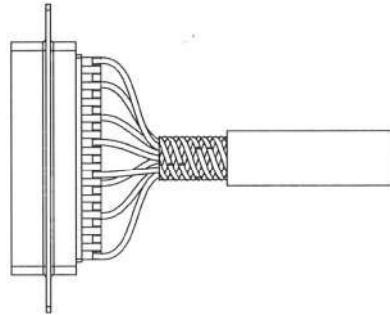

Attach the strain relief around the cable

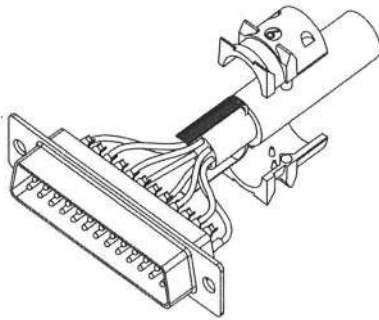

Bend cable shielding back
on outside of strain relief

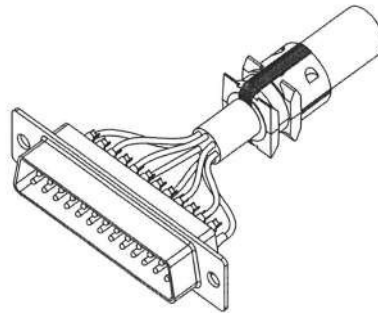

Mount connector and cable
into the backshell

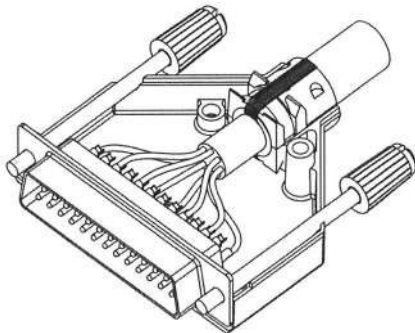

Assemble the other half
screwing force: 100-120 Ncm.

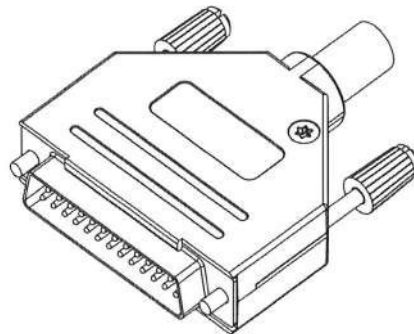

THIS DRAWING MAY NOT BE COPIED OR
REPRODUCED IN ANY WAY, AND MAY NOT
BE PASSED ON TO A THIRD PARTY WITHOUT
WRITTEN PERMISSION.
OWNERSHIP AND COPYRIGHT OF CONEC GmbH
DO NOT ALTER CAD DRAWING BY HAND

			tolerance		 dim. in mm
			2011	date	name
			drawn	30.11.	Lehmenkühler
			appd.	30.11.	Fischer
			norm		
			d-old		
a	Original		CONEC [®]		
rev.	description	date			

scale:

material:

title:

ASSEMBLY INSTRUCTION
METAL HOOD 9-37pos. EMI/RFI SHIELDING
with straight cable exit and jack screws

dwg no:

16K1A1784

DIN-A

4

sh:2/2

part no:

SEE SHEET 1

4

3

2

1

A

A