

**SC702CT STEREO A/V DIRECT BOX**

Switchcraft® SC702CT Stereo A/V Direct Boxes convert the outputs of equipment such as MP3 players, laptops and DJ mixers to balanced, mic level signals that can be connected to audio consoles, mic preamps and house sound systems. Two fully shielded isolation transformers galvanically isolate input and output connections, creating a pair of ultra-clean audio signals immune from hum and buzz caused by ground loops and RF interference.

Additional features include a 20dB pad for extra hot input signals, a merge switch to interface with mono sound systems, and a ground lift switch for eliminating grounding issues common with unbalanced equipment.

**USES:**

**STAGE:**

Connect MP3/CD players, samplers, DJ mixers, guitars, keyboards and other musical instruments to house sound systems and audio consoles.

**LECTURES / PRESENTATIONS:**

Connect laptops and MP3/CD players to house sound systems in conference rooms and auditoriums.

**CONTROLS:**

**INPUTS (1/4", RCA, 3.5mm):**

Accepts unbalanced stereo signals from headphone outputs and line sources such as laptops and MP3/CD players. Each left and right input is wired in parallel, enabling an unused input to act as a thrupt.

**OUTPUTS (Male XLR):**

Provides separate transformer isolated, balanced mic level outputs for left and right signals.

**-20dB PAD (Pushbutton Switch):**

Reduces output by 20dB for use with hot input signals.

**MONO MERGE (Pushbutton Switch)**

Combines the left and right stereo input signal into a mono signal that is output to both XLRs.

**LIFT/GND (Toggle Switch):**

Ground lift switch. Disconnects ground (pin-1) connection between input and isolated output XLRs. Use to break ground loops to further reduce hum & buzz.

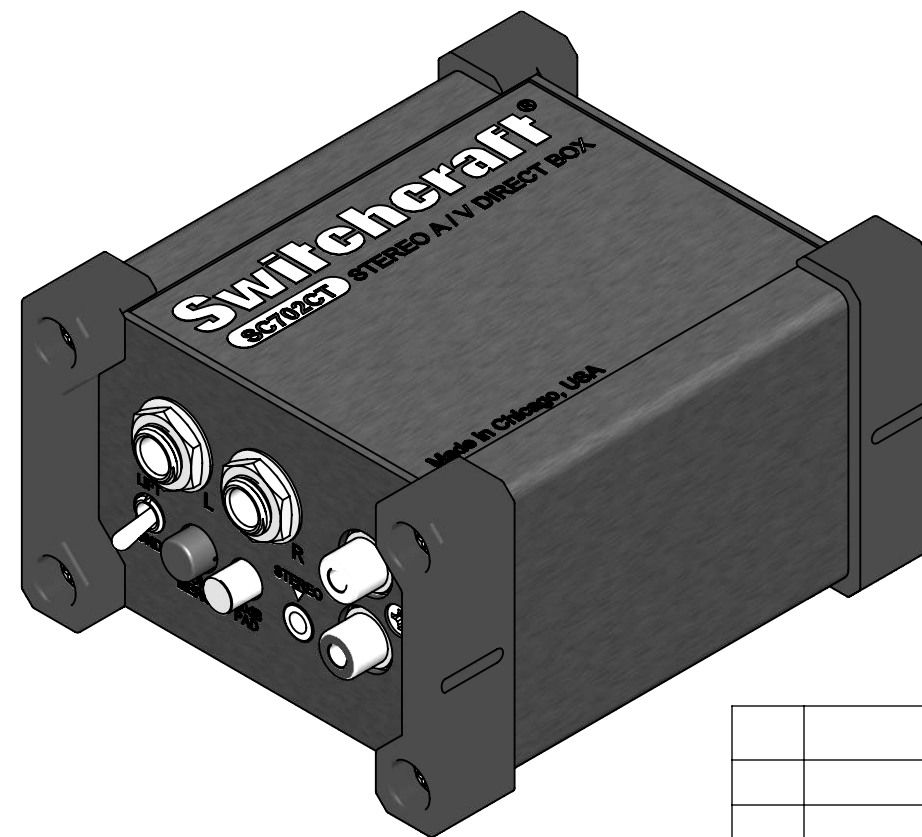
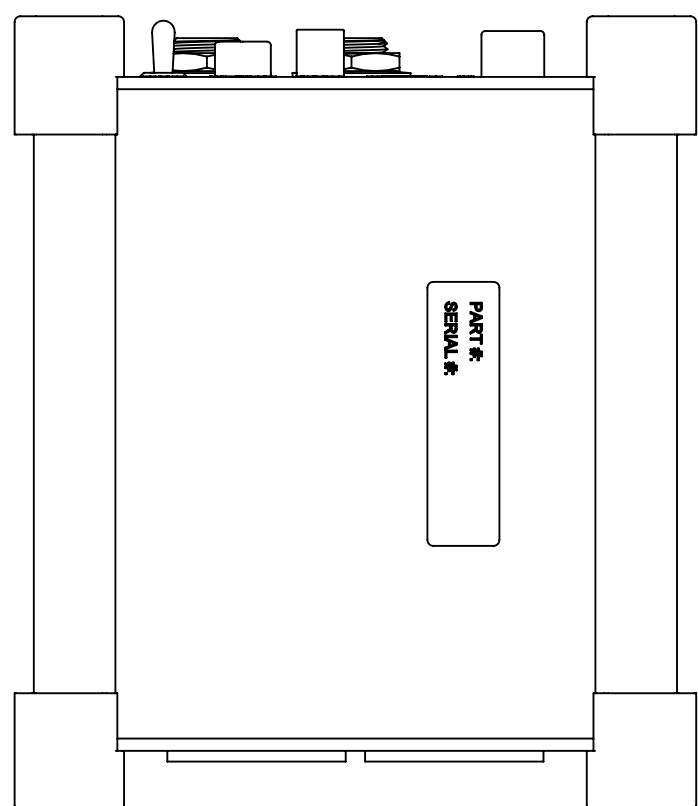
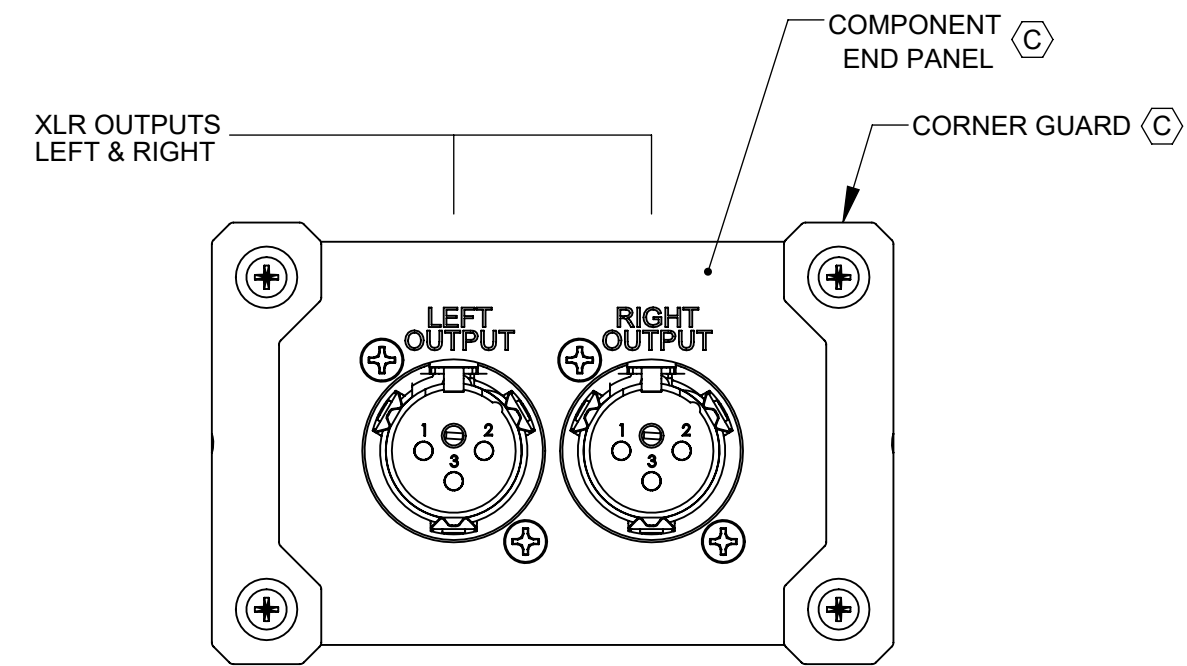
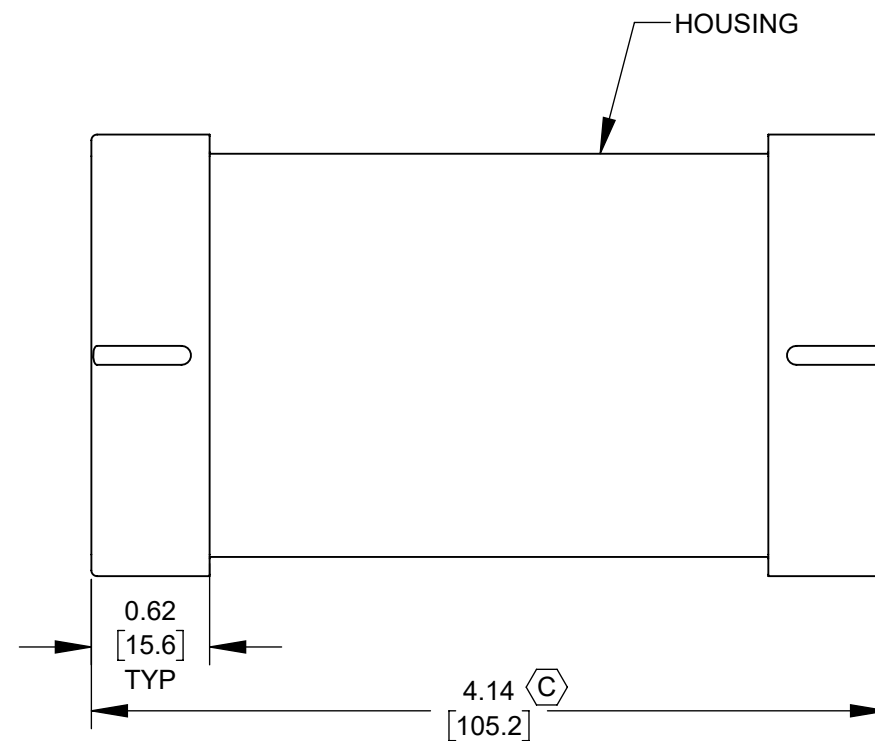
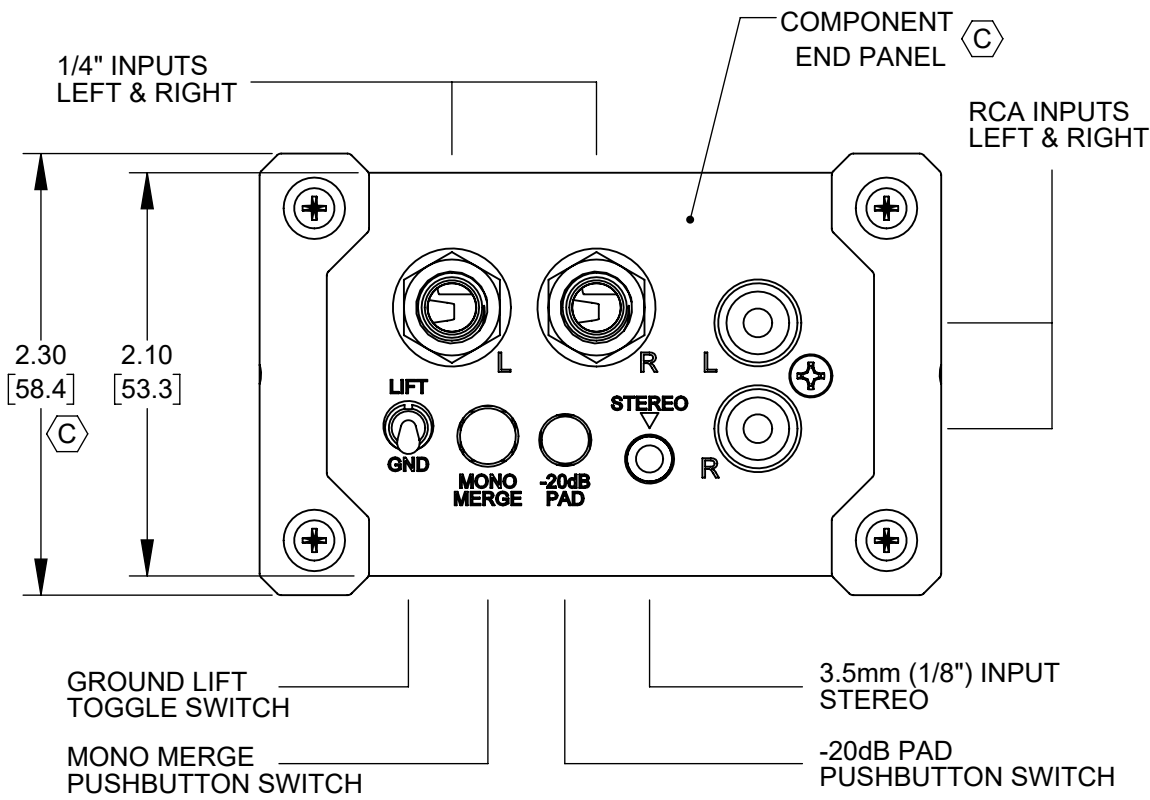

**NOTES:**

- ALL XLR CONNECTORS ARE WIRED: PIN-1 GROUND, PIN-2 HOT AND PIN-3 COLD
- MATERIALS: HOUSING AND COMPONENT END PANELS - ALUMINUM, BLACK ANODIZED; CORNER GAURDS - PVC, RED
- LASER ETCHED WHITE TEXT AND ARTWORK.
- THIS PRODUCT IS RoHS COMPLIANT.

**CUSTOMER DRAWING**

UNLESS OTHERWISE SPECIFIED					THIS DRAWING DESCRIBES A DESIGN CONSIDERED PROPRIETARY IN NATURE, DEVELOPED AND MANUFACTURED BY SWITCHCRAFT INC. AND IS RELEASED ON A CONFIDENTIAL BASIS FOR IDENTIFICATION PURPOSES ONLY.				
1. ALL DIMENSIONS IN INCHES [mm]					SIZE	WIDTH	MULT	LBS/M	TEMPER
- TWO PLACE DECIMALS ±0.02 [0.5]					FINISH				MATERIAL
- THREE PLACE DECIMALS ±0.005 [0.13]					FIRST USED ON				SPEC No.
					SCALE				
					DATE DRAWN	BY	CHKD	APVD	
					12-11-14	EB	PC	TJK	
					03-02-17				03-02-17
					NAME				PART No.
					STEREO A/V DIRECT BOX, RoHS				SC702CT
					DO NOT SCALE DRAWING				REV
									C

# SC702CT Stereo A/V Direct Box

## Audio Specifications

# Switchcraft®

Parameter	Performance	Conditions
Frequency Response	20Hz - 20kHz	+/-0.3dB, ref 1kHz
Total Harmonic Distortion + Noise	< 0.007% < 0.4%	at 1kHz, +4dBu Input, 22kHz Bandwidth at 20Hz, +4dBu Input, 22kHz Bandwidth
Maximum Input Level	+18dBu	at 20Hz with 1% THD+Noise
Input Impedance	> 120kΩ	at 1kHz
Output Impedance	< 50Ω	at 1kHz
Common Mode Rejection Ratio (CMRR)	> 105dB	at 60Hz
Deviation from Linear Phase	< 6° < 1° < 11°	at 20Hz at 1kHz at 20kHz
Voltage Gain	-23dB -43dB	+/-1dB +/-1dB with 20dB pad engaged
Pad Attenuation	20dB	+/-1dB

Notes: All measurements were taken with a 25Ω unbalanced source and measured from the XLR with a 1kΩ balanced load.  
Specifications subject to change without notice.

CUSTOMER DRAWING

SCALE 1:1	Switchcraft®	
DATE DRAWN 11-15-11		
DRAWN BY BHM	PART No. SC702CT	REV C

# SCHEMATIC

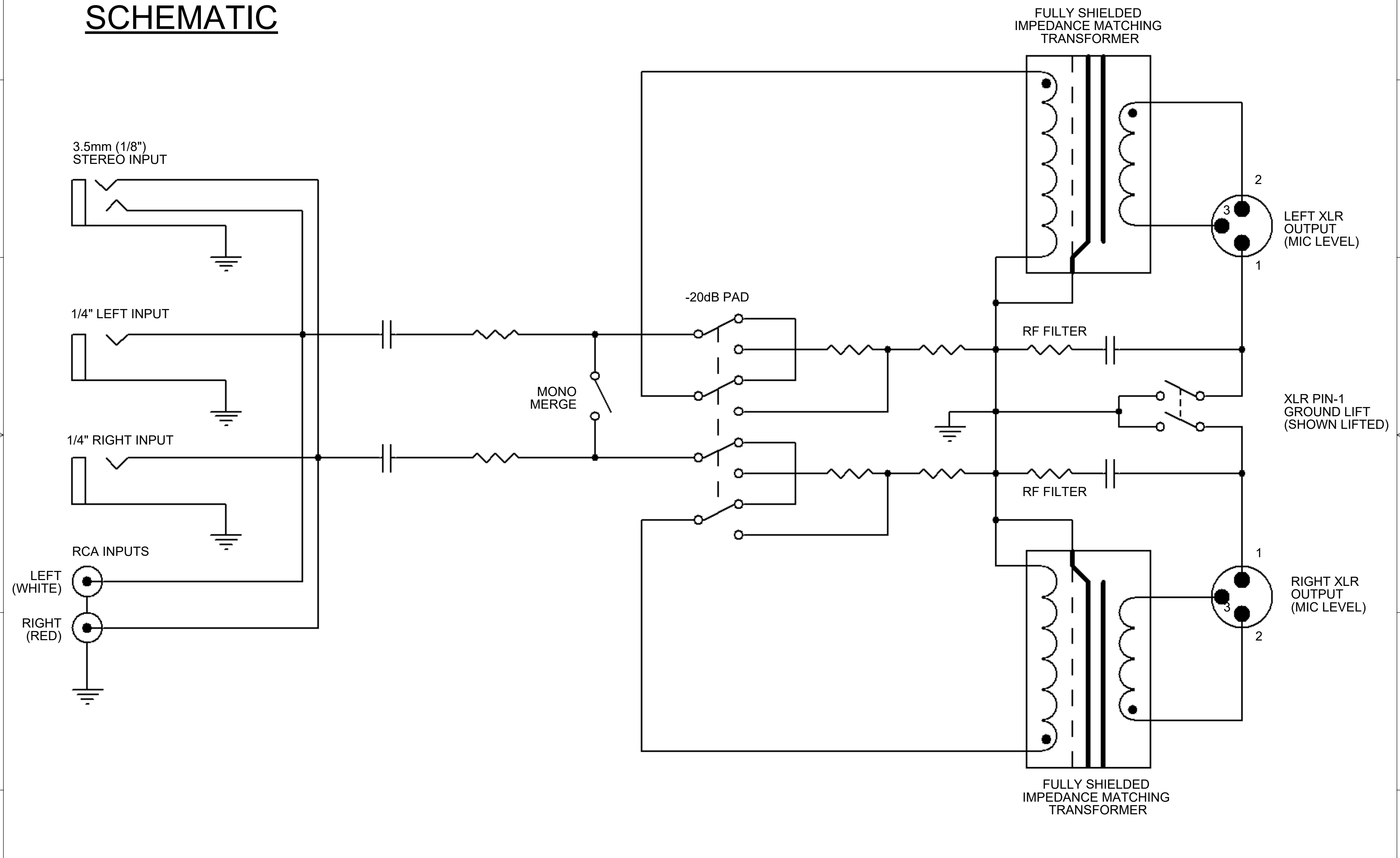

**CUSTOMER DRAWING**

SCALE 1:1	<b>Switchcraft®</b>	
DATE DRAWN 11-15-11		
DRAWN BY BHM	PART No. SC702CT	REV C