

IRG4BC20K-S

Short Circuit Rated
UltraFast IGBT

Features

- High short circuit rating optimized for motor control, $t_{sc} = 10\mu s$, @360V V_{CE} (start), $T_J = 125^\circ C$, $V_{GE} = 15V$
- Combines low conduction losses with high switching speed
- Latest generation design provides tighter parameter distribution and higher efficiency than previous generations

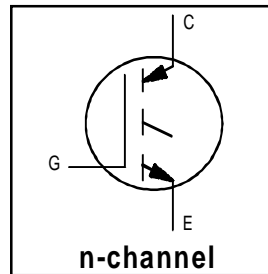

| |
|-----------------------------------|
| $V_{CES} = 600V$ |
| $V_{CE(on)} \text{ typ.} = 2.27V$ |
| @ $V_{GE} = 15V, I_C = 9.0A$ |

Benefits

- As a Freewheeling Diode we recommend our HEXFRED™ ultrafast, ultrasoft recovery diodes for minimum EMI / Noise and switching losses in the Diode and IGBT
- Latest generation 4 IGBTs offer highest power density motor controls possible
- This part replaces the IRGBC20K-S and IRGBC20M-S devices

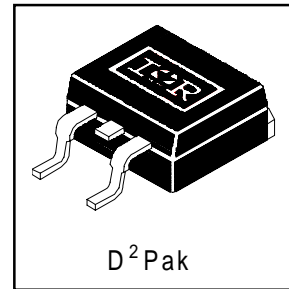

Absolute Maximum Ratings

| | Parameter | Max. | Units |
|---------------------------|------------------------------------|--------------------|------------|
| V_{CES} | Collector-to-Emitter Voltage | 600 | V |
| $I_C @ T_C = 25^\circ C$ | Continuous Collector Current | 16 | A |
| $I_C @ T_C = 100^\circ C$ | Continuous Collector Current | 9.0 | |
| I_{CM} | Pulsed Collector Current ① | 32 | |
| I_{LM} | Clamped Inductive Load Current ② | 32 | |
| t_{sc} | Short Circuit Withstand Time | 10 | μs |
| V_{GE} | Gate-to-Emitter Voltage | ± 20 | V |
| E_{ARV} | Reverse Voltage Avalanche Energy ③ | 29 | mJ |
| $P_D @ T_C = 25^\circ C$ | Maximum Power Dissipation | 60 | W |
| $P_D @ T_C = 100^\circ C$ | Maximum Power Dissipation | 24 | |
| T_J | Operating Junction and | -55 to +150 | $^\circ C$ |
| T_{STG} | Storage Temperature Range | | |
| | Soldering Temperature, for 10 sec. | | |
| | Mounting torque, 6-32 or M3 screw. | 10 lbf•in (1.1N•m) | |

Thermal Resistance

| | Parameter | Typ. | Max. | Units |
|-----------------|--|------|------|--------------|
| $R_{\theta JC}$ | Junction-to-Case | — | 2.1 | $^\circ C/W$ |
| $R_{\theta CS}$ | Case-to-Sink, Flat, Greased Surface | 0.5 | — | |
| $R_{\theta JA}$ | Junction-to-Ambient (PCB Mounted, steady-state) ④ | — | 40 | |
| Wt | Weight | 1.44 | — | g |

IRG4BC20K-S

Electrical Characteristics @ $T_J = 25^\circ\text{C}$ (unless otherwise specified)

| | Parameter | Min. | Typ. | Max. | Units | Conditions | |
|---------------------------------|--|------|------|-----------|---------------|---|---------------------|
| $V_{(BR)CES}$ | Collector-to-Emitter Breakdown Voltage | 600 | — | — | V | $V_{GE} = 0\text{V}$, $I_C = 250\mu\text{A}$ | |
| $V_{(BR)ECS}$ | Emitter-to-Collector Breakdown Voltage ④ | 18 | — | — | V | $V_{GE} = 0\text{V}$, $I_C = 1.0\text{A}$ | |
| $\Delta V_{(BR)CES}/\Delta T_J$ | Temperature Coeff. of Breakdown Voltage | — | 0.49 | — | V/°C | $V_{GE} = 0\text{V}$, $I_C = 1.0\text{mA}$ | |
| $V_{CE(ON)}$ | Collector-to-Emitter Saturation Voltage | — | 2.00 | — | V | $V_{GE} = 15\text{V}$ See Fig.2, 5 | |
| | | — | 2.27 | 2.8 | | | $I_C = 6.0\text{A}$ |
| | | — | 3.01 | — | | | $I_C = 9.0\text{A}$ |
| | | — | 2.43 | — | | | $I_C = 16\text{A}$ |
| $V_{GE(th)}$ | Gate Threshold Voltage | 3.0 | — | 6.0 | | $V_{CE} = V_{GE}$, $I_C = 250\mu\text{A}$ | |
| $\Delta V_{GE(th)}/\Delta T_J$ | Temperature Coeff. of Threshold Voltage | — | -10 | — | mV/°C | $V_{CE} = V_{GE}$, $I_C = 250\mu\text{A}$ | |
| g_{fe} | Forward Transconductance ⑤ | 2.9 | 4.3 | — | S | $V_{CE} = 100\text{V}$, $I_C = 9.0\text{A}$ | |
| I_{CES} | Zero Gate Voltage Collector Current | — | — | 250 | μA | $V_{GE} = 0\text{V}$, $V_{CE} = 600\text{V}$ | |
| | | — | — | 2.0 | | $V_{GE} = 0\text{V}$, $V_{CE} = 10\text{V}$, $T_J = 25^\circ\text{C}$ | |
| | | — | — | 1000 | | $V_{GE} = 0\text{V}$, $V_{CE} = 600\text{V}$, $T_J = 150^\circ\text{C}$ | |
| I_{GES} | Gate-to-Emitter Leakage Current | — | — | ± 100 | nA | $V_{GE} = \pm 20\text{V}$ | |

Switching Characteristics @ $T_J = 25^\circ\text{C}$ (unless otherwise specified)

| | Parameter | Min. | Typ. | Max. | Units | Conditions |
|--------------|-----------------------------------|------|------|------|---------------|---|
| Q_g | Total Gate Charge (turn-on) | — | 34 | 51 | nC | $I_C = 9.0\text{A}$ $V_{CC} = 400\text{V}$ $V_{GE} = 15\text{V}$ See Fig.8 |
| Q_{ge} | Gate - Emitter Charge (turn-on) | — | 4.9 | 7.4 | | |
| Q_{gc} | Gate - Collector Charge (turn-on) | — | 14 | 21 | | |
| $t_{d(on)}$ | Turn-On Delay Time | — | 28 | — | ns | $T_J = 25^\circ\text{C}$ $I_C = 9.0\text{A}$, $V_{CC} = 480\text{V}$ $V_{GE} = 15\text{V}$, $R_G = 50\Omega$ Energy losses include "tail" See Fig. 9,10,14 |
| t_r | Rise Time | — | 27 | — | | |
| $t_{d(off)}$ | Turn-Off Delay Time | — | 150 | 220 | | |
| t_f | Fall Time | — | 100 | 150 | | |
| E_{on} | Turn-On Switching Loss | — | 0.15 | — | mJ | See Fig. 9,10,14 |
| E_{off} | Turn-Off Switching Loss | — | 0.25 | — | | |
| E_{ts} | Total Switching Loss | — | 0.40 | 0.6 | | |
| t_{sc} | Short Circuit Withstand Time | 10 | — | — | μs | $V_{CC} = 400\text{V}$, $T_J = 125^\circ\text{C}$ $V_{GE} = 15\text{V}$, $R_G = 50\Omega$, $V_{CPK} < 500\text{V}$ |
| $t_{d(on)}$ | Turn-On Delay Time | — | 28 | — | ns | $T_J = 150^\circ\text{C}$, $I_C = 9.0\text{A}$, $V_{CC} = 480\text{V}$ $V_{GE} = 15\text{V}$, $R_G = 50\Omega$ Energy losses include "tail" See Fig. 11,14 |
| t_r | Rise Time | — | 29 | — | | |
| $t_{d(off)}$ | Turn-Off Delay Time | — | 190 | — | | |
| t_f | Fall Time | — | 190 | — | | |
| E_{ts} | Total Switching Loss | — | 0.68 | — | mJ | $T_J = 25^\circ\text{C}$, $V_{GE} = 15\text{V}$, $R_G = 50\Omega$ $I_C = 6.0\text{A}$, $V_{CC} = 480\text{V}$ Energy losses include "tail" |
| E_{on} | Turn-On Switching Loss | — | 0.07 | — | | |
| E_{off} | Turn-Off Switching Loss | — | 0.13 | — | | |
| E_{ts} | Total Switching Loss | — | 0.20 | — | nH | Measured 5mm from package |
| L_E | Internal Emitter Inductance | — | 7.5 | — | | |
| C_{ies} | Input Capacitance | — | 450 | — | | |
| C_{oes} | Output Capacitance | — | 61 | — | pF | $V_{CC} = 30\text{V}$ See Fig. 7 |
| C_{res} | Reverse Transfer Capacitance | — | 14 | — | | |
| | | | | | | $f = 1.0\text{MHz}$ |

Details of note ① through ⑥ are on the last page

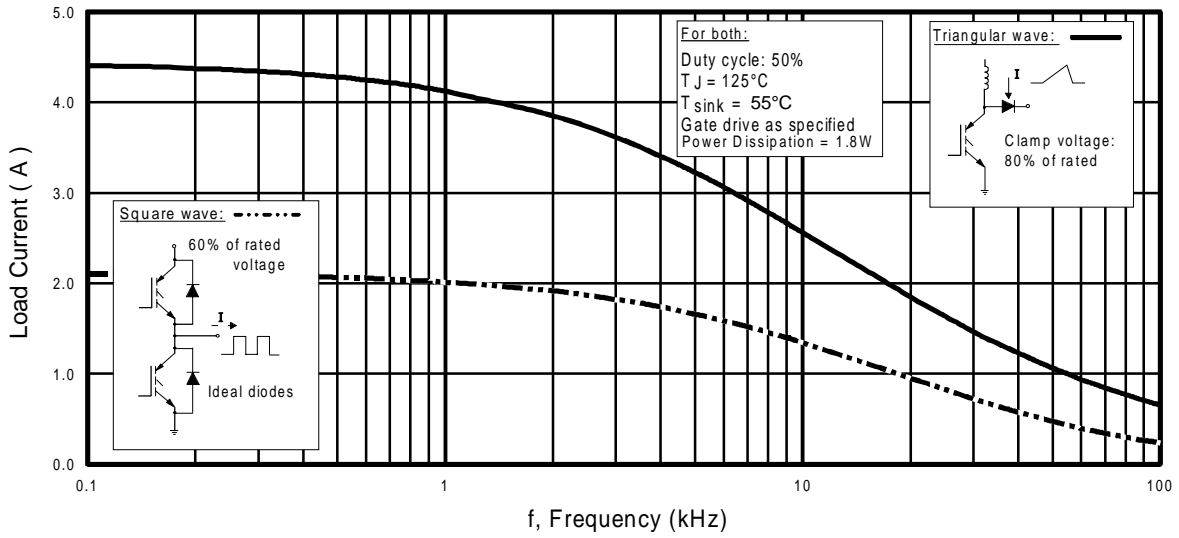

Fig. 1 - Typical Load Current vs. Frequency
(Load Current = I_{RMS} of fundamental)

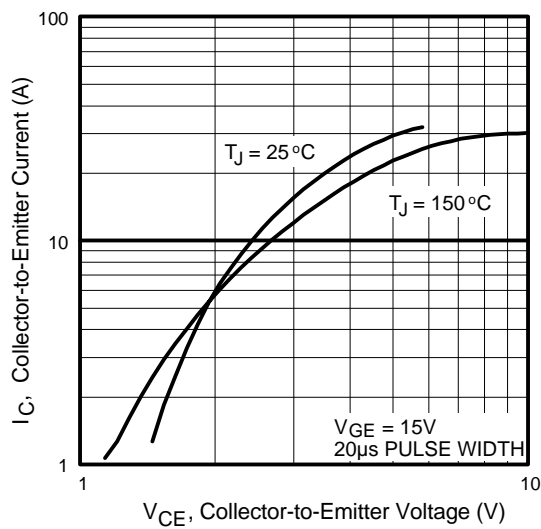

Fig. 2 - Typical Output Characteristics

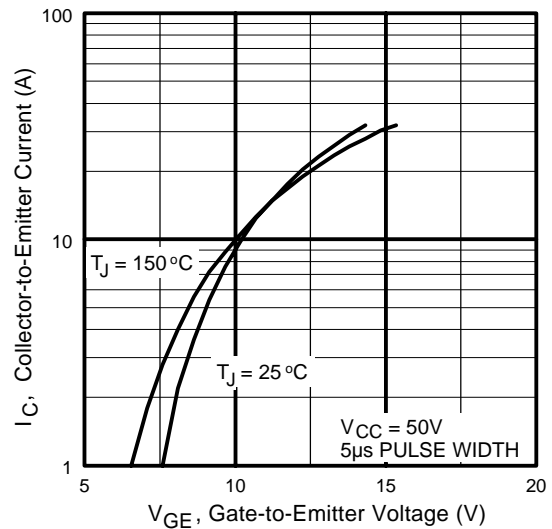

Fig. 3 - Typical Transfer Characteristics

IRG4BC20K-S

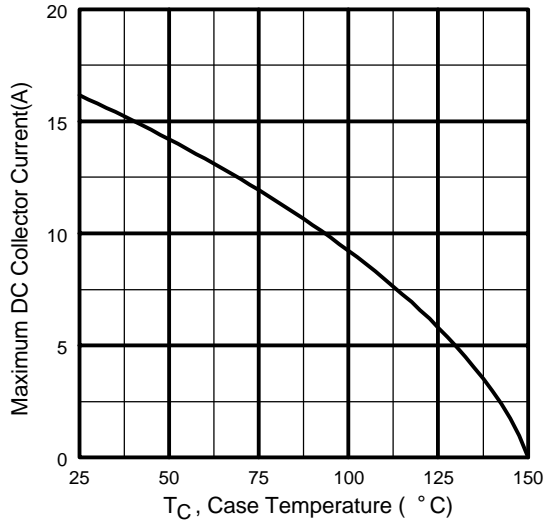

Fig. 4 - Maximum Collector Current vs. Case Temperature

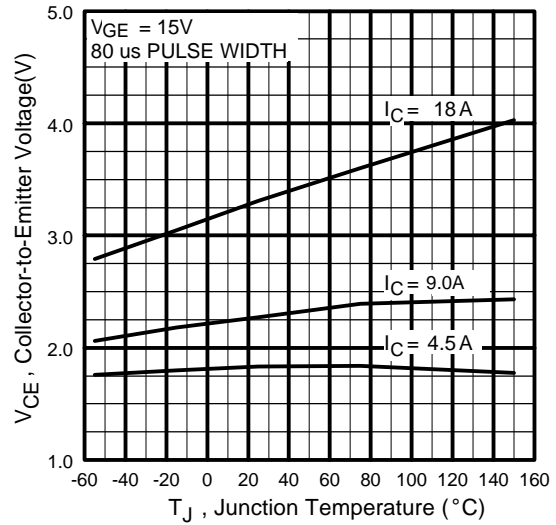

Fig. 5 - Typical Collector-to-Emitter Voltage vs. Junction Temperature

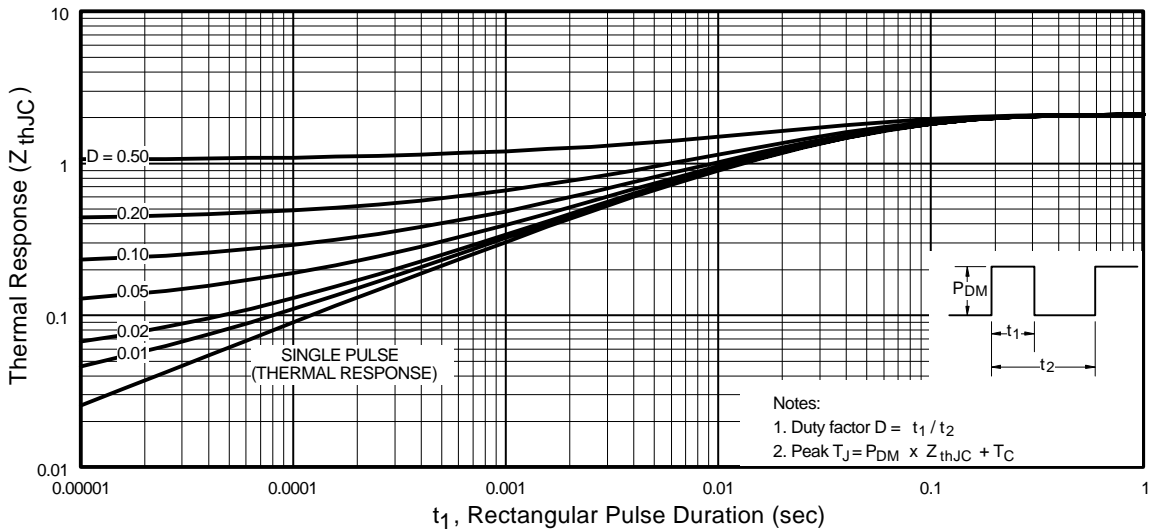

Fig. 6 - Maximum Effective Transient Thermal Impedance, Junction-to-Case

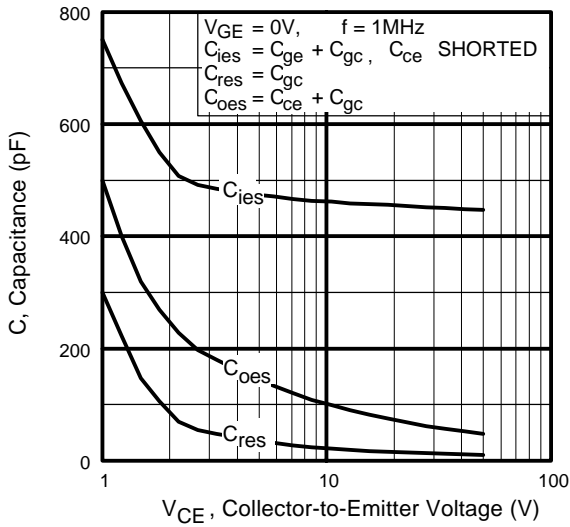

Fig. 7 - Typical Capacitance vs. Collector-to-Emitter Voltage

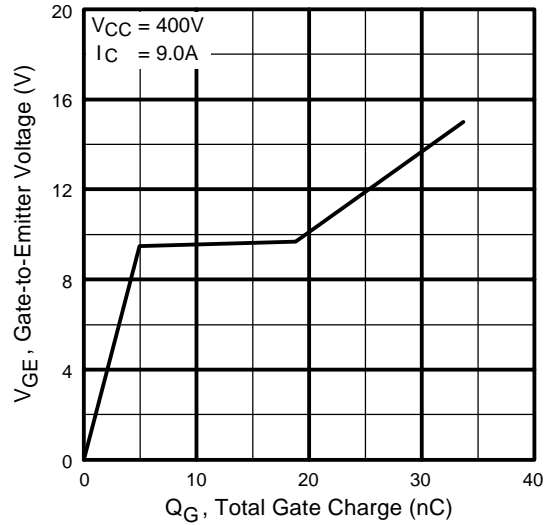

Fig. 8 - Typical Gate Charge vs. Gate-to-Emitter Voltage

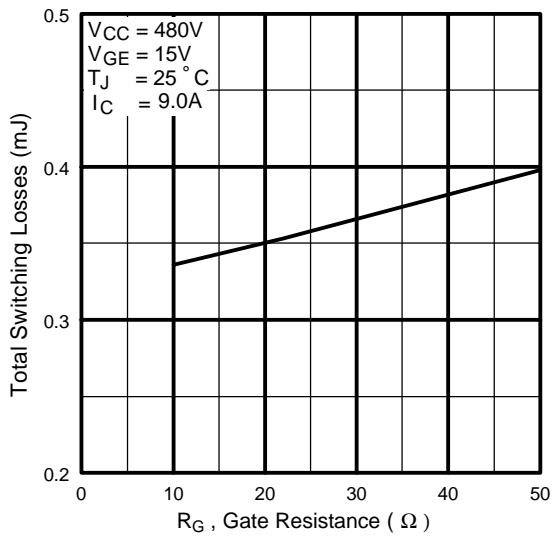

Fig. 9 - Typical Switching Losses vs. Gate Resistance

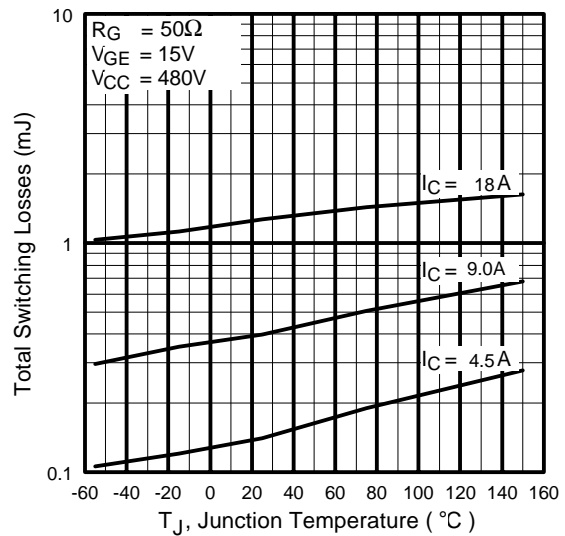

Fig. 10 - Typical Switching Losses vs. Junction Temperature

IRG4BC20K-S

International
IR Rectifier

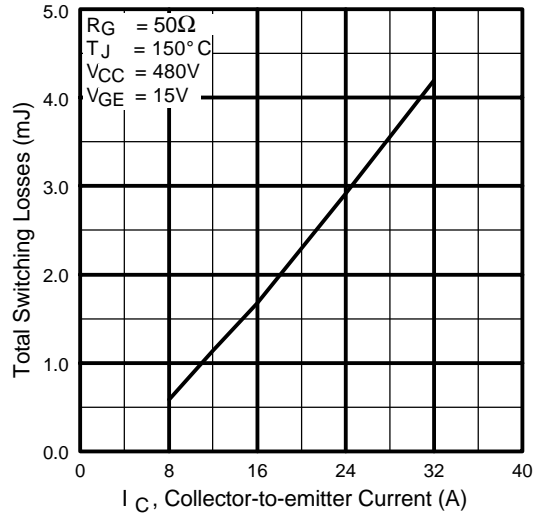

Fig. 11 - Typical Switching Losses vs. Collector-to-emitter Current

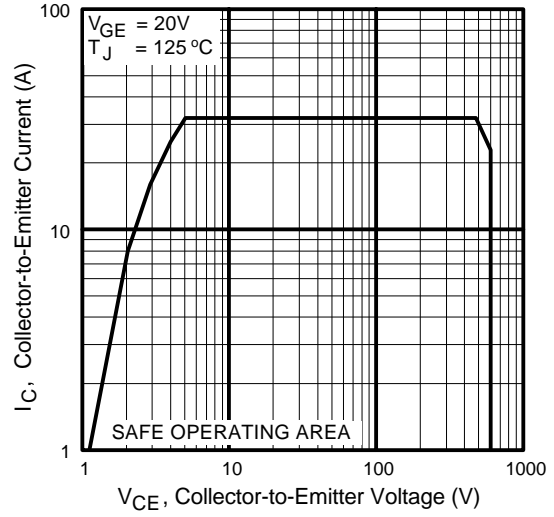
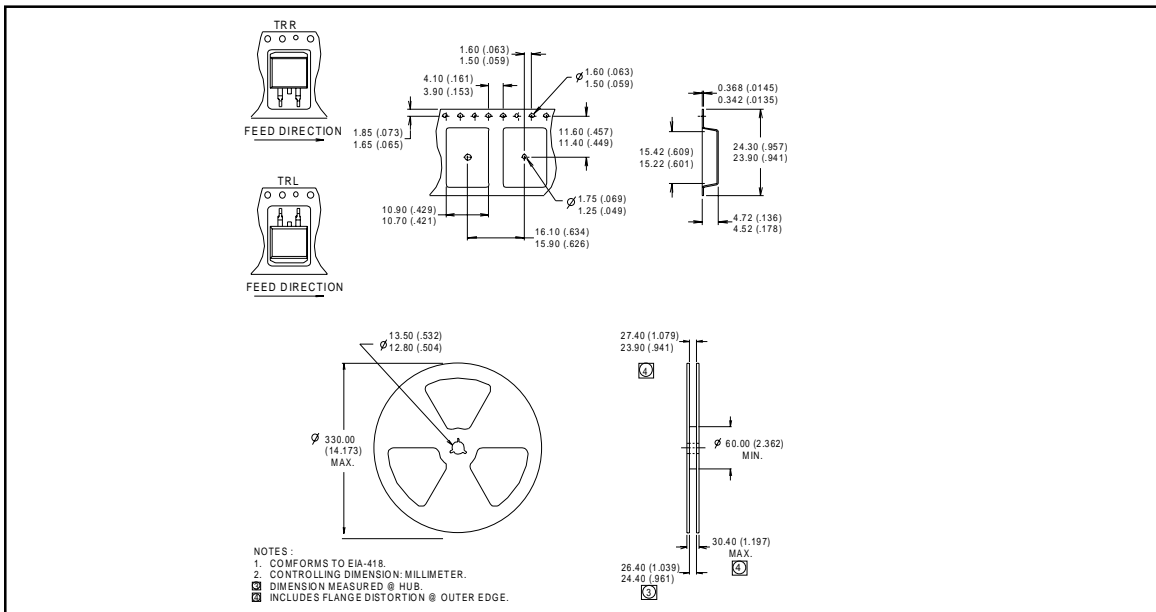

Fig. 12 - Turn-Off SOA

Tape & Reel Information

D²Pak



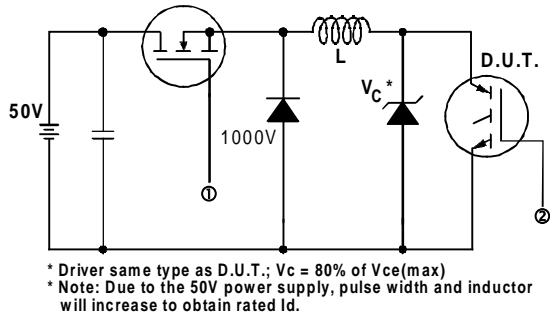

Fig. 13a - Clamped Inductive Load Test Circuit

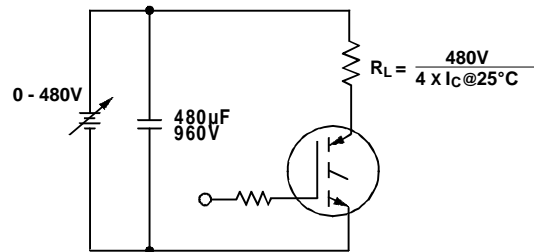

Fig. 13b - Pulsed Collector Current Test Circuit

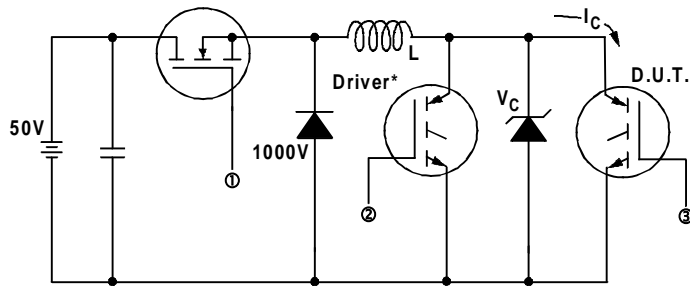

Fig. 14a - Switching Loss Test Circuit

* Driver same type as D.U.T., $V_C = 480V$

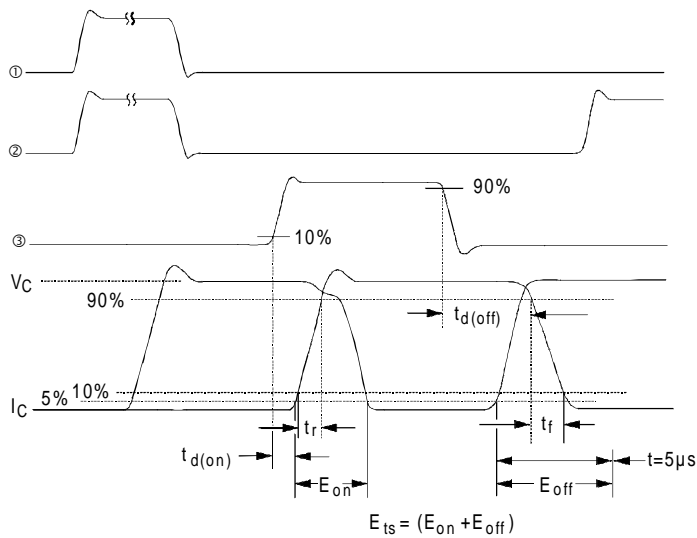

Fig. 14b - Switching Loss Waveforms

IRG4BC20K-S

International
IR Rectifier

Notes:

- ① Repetitive rating; $V_{GE} = 20V$, pulse width limited by max. junction temperature. (See fig. 13b)
- ② $V_{CC} = 80\%(V_{CES})$, $V_{GE} = 20V$, $L = 10\mu H$, $R_G = 50\Omega$, (See fig. 13a)
- ③ Repetitive rating; pulse width limited by maximum junction temperature.
- ④ Pulse width $\leq 80\mu s$; duty factor $\leq 0.1\%$.
- ⑤ Pulse width $5.0\mu s$, single shot.
- ⑥ When mounted on 1" square PCB (FR-4 or G-10 Material). For recommended footprint and soldering techniques refer to application note #AN-994.

D²Pak Package Outline

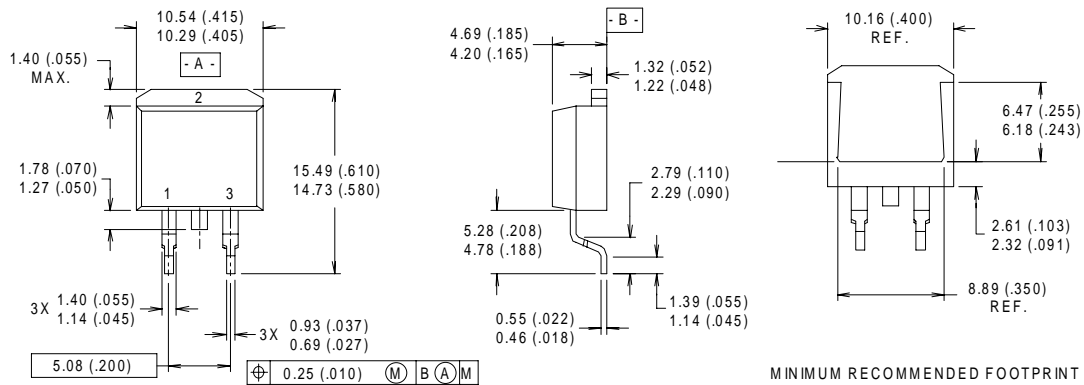

NOTES:

- 1 DIMENSIONS AFTER SOLDER DIP.
- 2 DIMENSIONING & TOLERANCING PER ANSII Y14.5M, 1982.
- 3 CONTROLLING DIMENSION : INCH.
- 4 HEATSINK & LEAD DIMENSIONS DO NOT INCLUDE BURRS.

LEAD ASSIGNMENTS

- 1 - GATE
- 2 - DRAIN
- 3 - SOURCE

MINIMUM RECOMMENDED FOOTPRINT

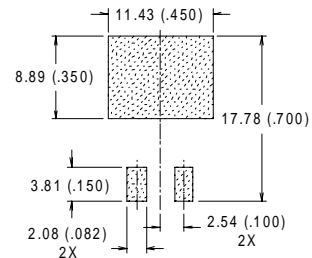

International
IR Rectifier

IR WORLD HEADQUARTERS: 233 Kansas St., El Segundo, California 90245, USA Tel: (310) 252-7105
IR EUROPEAN REGIONAL CENTRE: 439/445 Godstone Rd, Whyteleafe, Surrey CR3 0BL, UK Tel: ++ 44 (0)20 8645 8000

IR CANADA: 15 Lincoln Court, Brampton, Ontario L6T3Z2, Tel: (905) 453 2200

IR GERMANY: Saalburgstrasse 157, 61350 Bad Homburg Tel: ++ 49 (0) 6172 96590

IR ITALY: Via Liguria 49, 10071 Borgaro, Torino Tel: ++ 39 011 451 0111

IR JAPAN: K&H Bldg., 2F, 30-4 Nishi-Ikebukuro 3-Chome, Toshima-Ku, Tokyo 171 Tel: 81 (0)3 3983 0086

IR SOUTHEAST ASIA: 1 Kim Seng Promenade, Great World City West Tower, 13-11, Singapore 237994 Tel: ++ 65 (0)838 4630

IR TAIWAN: 16 Fl. Suite D. 207, Sec. 2, Tun Haw South Road, Taipei, 10673 Tel: 886-(0)2 2377 9936

Data and specifications subject to change without notice. 10/00

Note: For the most current drawings please refer to the IR website at:
<http://www.irf.com/package/>