



LED Display
Product Data Sheet
LSHD-A103

Spec No. :DS30-2002-148
Effective Date: 06/03/2017
Revision: B

LITE-ON DCC

RELEASE

BNS-OD-FC001/A4

**LED DISPLAY
LSHD-A103**

LED DISPLAY

LSHD-A103

<u>Rev</u>	<u>Description</u>	<u>By</u>	<u>Date</u>
-			
Above data for PD and Customer tracking only			
-	New	Thomas Yu	12/31/2002
A	Update rev in system	Reo Lin	04/27/2011
B	Update rev in system	Erin Cheng	05/26/2017

LED DISPLAY LSHD-A103

1. Description

The LSHD-A103 is a 0.3 inch (7.62 mm) digit height single-digit display. This device uses AllnGaP RED LED chips (AllnGaP epi on GaAs substrate). The display has light gray face and white segments.

1.1 Features

- 0.3 inch (7.62 mm) DIGIT HEIGHT
- CONTINUOUS UNIFORM SEGMENTS
- LOW POWER REQUIREMENT
- EXCELLENT CHARACTERS APPEARANCE
- HIGH BRIGHTNESS & HIGH CONTRAST
- WIDE VIEWING ANGLE
- SOLID STATE RELIABILITY
- CATEGORIZED FOR LUMINOUS INTENSITY.
- LEAD-FREE PACKAGE (ACCORDING TO ROHS)

1.2 Device

Part No	Description
AllnGaP RED	Common Cathode
LSHD-A103	Rt. Hand Decimal

**LED DISPLAY
LSHD-A103**

2. Package Dimensions

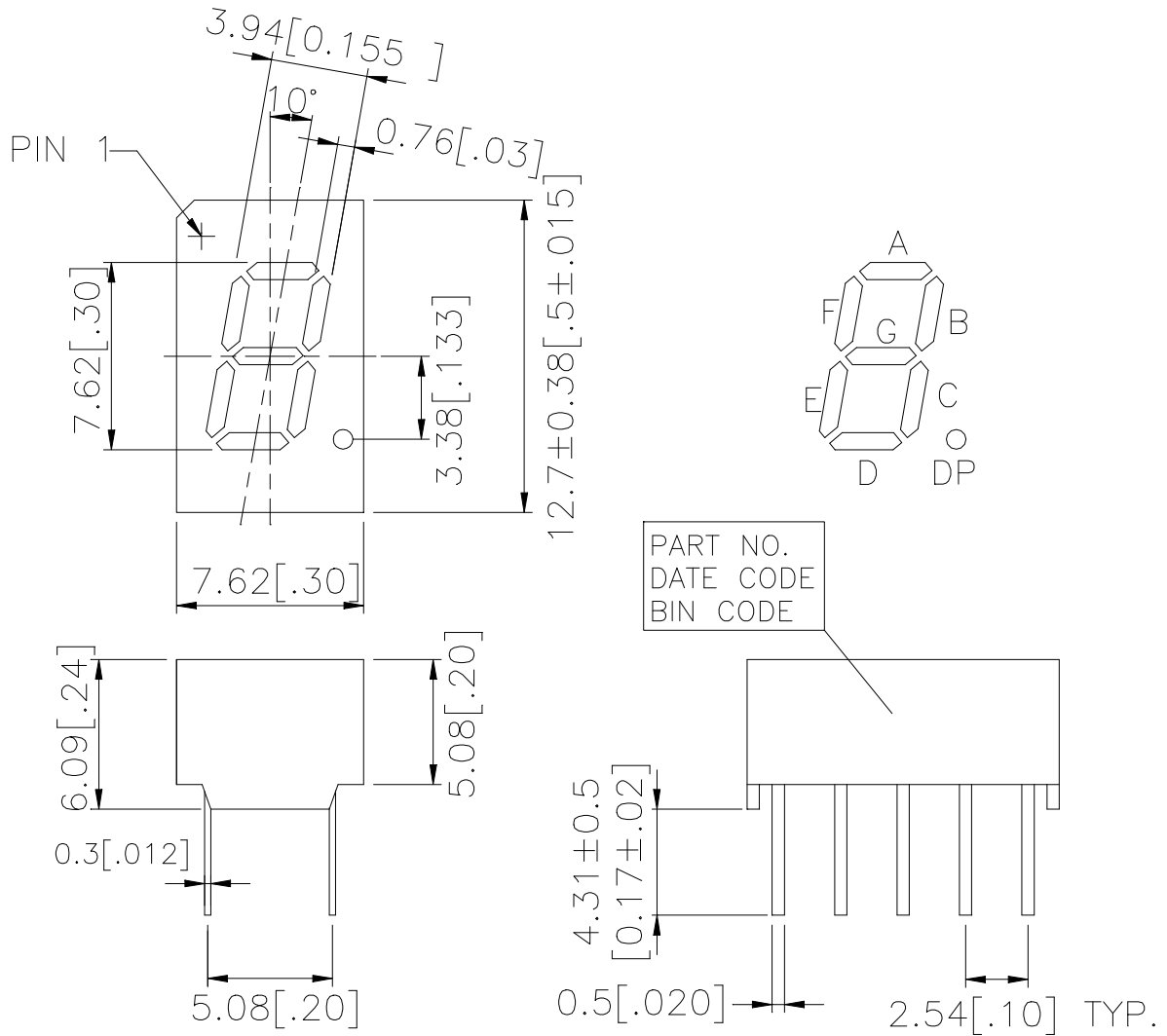

Notes :

1. All dimensions are in millimeters. Tolerances are ±0.25 mm (0.01") unless otherwise noted
2. Pin tip's shift tolerance is ± 0.4 mm
3. Foreign material on segment ≤ 10mil
4. Ink contamination (surface) ≤ 20mils
5. Bubble in segment ≤ 10mil
6. Bending ≤ 1% of reflector length

**LED DISPLAY
LSHD-A103**

3. Internal Circuit Diagram

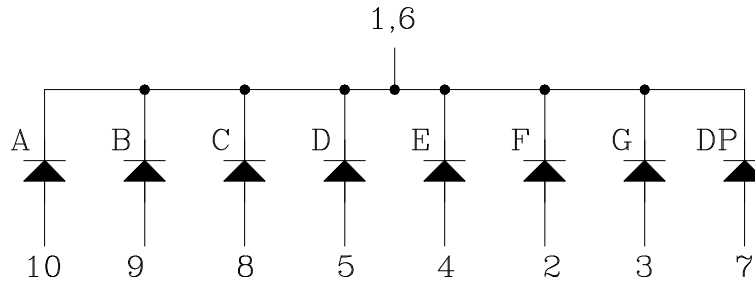

4. Pin Connection

No	Connection
1	Common Cathode
2	Anode F
3	Anode G
4	Anode E
5	Anode D
6	Common Cathode
7	Anode DP
8	Anode C
9	Anode B
10	Anode A

LED DISPLAY LSHD-A103

5. Rating and Characteristics

5.1. Absolute Maximum Rating at Ta=25°C

Parameter	Maximum Rating	Unit
Power Dissipation Per Segment	70	mW
Peak Forward Current Per Segment (1/10 Duty Cycle, 0.1ms Pulse Width)	90	mA
Continuous Forward Current Per Segment	25	mA
Derating Linear From 25°C Per Segment	0.28	mA/°C
Operating Temperature Range	-35°C to +105°C	
Storage Temperature Range	-35°C to +105°C	
Solder Condition: 1/16 inch below seating plane for 3 seconds at 260°C or temperature of unit (during assembly) not over max. temperature rating above		

5.2. Electrical / Optical Characteristics at Ta=25°C

Parameter	Symbol	MIN.	TYP.	MAX.	Unit	Test Condition
Average Luminous Intensity Per Segment	IV	200 3400	692 9000		μcd	IF=1mA IF=10mA
Peak Emission Wavelength	λp		650		nm	IF=20mA
Spectral Line Half-Width	Δλ		20		nm	IF=20mA
Dominant Wavelength	λd		639		nm	IF=20mA
Forward Voltage Per Chip	VF		2.1	2.6	V	IF=20mA
Reverse Current Per Segment ^(*)	IR			100	μA	VR=5V
Luminous Intensity Matching Ratio (Similar Light Area)	IV-m			2:1		IF=10mA

Notes :

- Luminous intensity is measured with a light sensor and filter combination that approximates the CIE (Commission International De L'Eclairiage) eye-response curve
- Reverse voltage is only for IR test. It cannot continue to operate at this situation

LED DISPLAY LSHD-A103

5.4. Typical Electrical / Optical Characteristics Curves

(25°C Ambient Temperature Unless Otherwise Noted)

