



Test Procedure for the NCP1568PD60WGEVB Evaluation Board

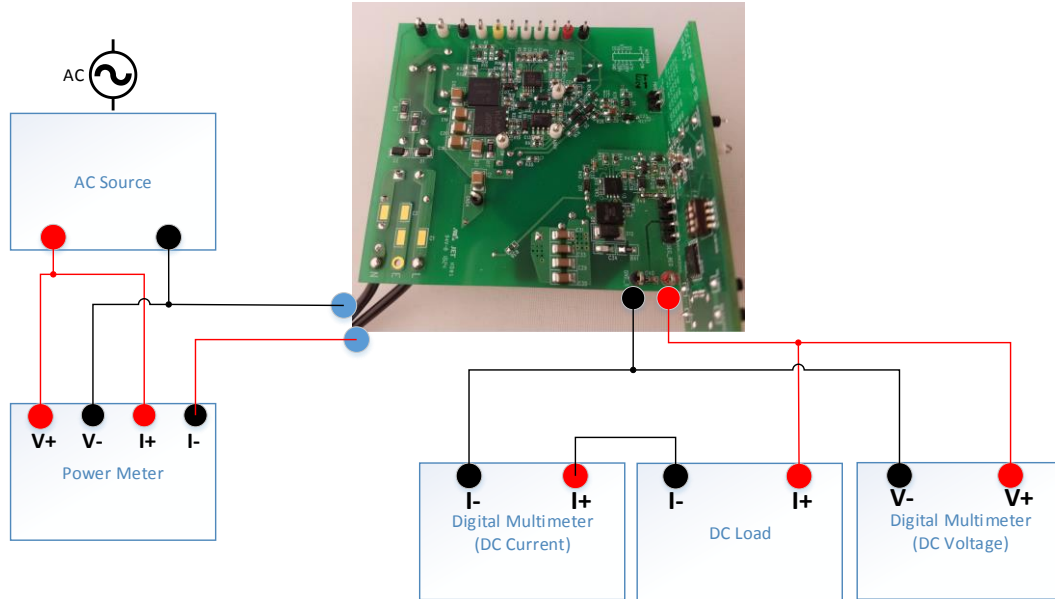

Table 1: Required Equipment

*Chroma 61604 AC Source	*Yokogawa WT210 Power Meter	*Agilent 34401A Digital Multimeter x2
*Kikusui PLZ303W DC Electronic Load	One NCP1568 Evaluation Board	

*Equivalent test equipment may be substituted

Table 2. 20 V Efficiency Measurements

Output Power [%]	Measured	Limit	Measurement				Calculated 4-point Avg. Efficiency Measurement	Limit
	10%		25%	50%	75%	100%		
Efficiency [%] @ VIN = 115 Vrms	86.5	78.9%	88.5	91.2	92.5	93.3	91.9	88 %
Efficiency [%] @ VIN = 230 Vrms	83.2	78.9%	88.1	90.7	92.7	93.5	91.2	88 %

Table 3. 5 V Efficiency Measurements

Output Power [%]	Measured	Limit	Measurement				Calculated 4-point Avg. Efficiency Measurement	Limit
	10%		25%	50%	75%	100%		
Efficiency [%] @ VIN = 115 Vrms	83.0	72.5%	86.2	89.9	90.7	90.8	89.4	82%
Efficiency [%] @ VIN = 230 Vrms	76.9	72.5%	79.5	87.9	90.2	90.6	87.0	82%



Test Procedure:

1. Connect the Agilent 34401A Digital Multimeter (measuring DC I) in series with the output terminals and the Kikusui PLZ303W DC Electronic Load. Reference figure 1.
2. Set Kikusui PLZ303W DC Electronic Load to C.C. mode.
3. Set load current on Kikusui PLZ303W DC Electronic Load to 500 mA.
4. Connect the Agilent 34401A Digital Multimeter (measuring DC V) to the output as shown on figure 1.
5. Connect the AC power source and power meter as shown in figure 1.
6. Set DIP switch on daughter board so that all 4 switches are in the top position (on).
7. Set the AC power source to 115 VAC, 60 Hz and turn on power source
8. Wait 10 seconds and verify that the voltage measured on Agilent voltage multimeter is 20 +/- 0.2 V. Verify load current on Agilent current multimeter.
9. Slowly increase the load current to 3 A. Verify on Agilent current multimeter that current is 3 A +/- 1%
10. Allow evaluation board to run for approximately 10 minute then use Yokogawa to measure input power. Calculate the efficiency and record measurements.
11. Take the efficiency readings at 2.25 A (75% load), 1.5 A (50% load), 0.75A (25% load) and 0.3A (10% load). Verify that the readings are close to as in table 2.
12. Set the AC power source to 230 VAC, 50 Hz and turn on power source
13. Repeat steps 8-11.
14. Turn off the AC power source.
15. Switch the DIP switch to all 4 in the bottom position (off).
16. Repeat steps 7-13, this time measuring the output for 5 +/- 0.05 V.
17. Turn off the AC power source.
18. Since high voltage will be present on bulk capacitor, C7 and C8, use a dc voltmeter to verify voltage is less than 50 VDC before continuing (if not, discharge bulk cap and clamp caps C32, C38, & C39)
19. Disconnect the ac source.
20. Disconnect the electronic load.
21. Disconnect multimeters.
22. End of test.